



ULTRA-HIGH DYNAMIC RANGE, SHUTDOWN

Monolithic Amplifier

TSS-13LN+

50Ω 1 MHz to 1 GHz

THE BIG DEAL

- Ultra-High IP3, +39.2 dBm typ.
- Gain, 22.8 dB typ. at 0.5 GHz
- Low supply voltage, +3 to +5V
- Excellent Noise Figure, 1.1 dB typ.
- Shutdown feature

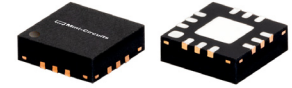

Generic photo used for illustration purposes only

CASE STYLE: DQ1225

+RoHS Compliant

The +Suffix identifies RoHS Compliance. See our website for methodologies and qualifications

APPLICATIONS

- Base station infrastructure
- CATV
- Cellular

PRODUCT OVERVIEW

TSS-13LN+ (RoHS compliant) is an advanced wideband amplifier with shutdown feature. It is fabricated using E-PHEMT technology and offers extremely high dynamic range over a broad frequency range and with low noise figure. In addition, the TSS-13LN+ has good input and output return loss over a broad frequency range. TSS-13LN+ is enclosed in a 3x3mm, 12-lead MCLP package and has very good thermal performance.

KEY FEATURES

Feature	Advantages
Broad Band: 1 MHz to 1 GHz	Broadband covering primary wireless communications bands: VHF, UHF, Cellular
Extremely High IP3 +38.4 dBm typical at 1 MHz +39.2 dBm typical at 0.5 GHz	The TSS-13LN+ matches industry leading IP3 performance relative to device size and power consumption. The combination of the design and E-PHEMT Structure provides enhanced linearity over a broad frequency range as evidence in the IP3 being approximately 11-18 dB above the P1dB point. This feature makes this amplifier ideal for use in: <ul style="list-style-type: none"> • Driver amplifiers for complex waveform up converter paths • Drivers in linearized transmit systems • Secondary amplifiers in ultra-High Dynamic range receivers
Shutdown feature	Allow users to turn on and off the amplifier with pulsed signals while keeping the power supply at constant voltage to minimize DC power consumption
Low Noise Figure 1.1 dB at 0.5 GHz	Enables lower system noise figure performance and along with High OIP3 provides high dynamic range
Low Supply Voltage	TSS-13LN+ supports low supply voltage operation which indicate low power consumption.

REV. A
ECO-011809
TSS-13LN+
MCL NY
240805





ULTRA-HIGH DYNAMIC RANGE, SHUTDOWN

Monolithic Amplifier

TSS-13LN+

Mini-Circuits

50Ω 1 MHz to 1 GHz

ELECTRICAL SPECIFICATIONS¹ AT +25°C & 50Ω, UNLESS NOTED OTHERWISE

Parameter	Condition (MHz)	Amplifier-ON			Amplifier-OFF	Amplifier-ON	Amplifier-OFF	Units
		V _{DD} = +5V			V _{DD} = +5V	V _{DD} = +3V	V _{DD} = +3V	
		Min.	Typ.	Max.	Typ.	Typ.	Typ.	
Frequency Range		1		1000	1-1000	1-1000	1-1000	MHz
Noise Figure	1		3.1			3.0		dB
	20		1.1			1.1		
	250		1.1			1.1		
	500		1.1			1.1		
	1000		1.2			1.3		
Gain	1	22.1	24.7	27.1	-24	23.9	-24	dB
	20	—	24.2	—	-22	23.5	-22	
	250	20.6	23.0	25.2	-21	22.3	-21	
	500	—	22.8	—	-22	21.9	-22	
	1000	18.2	20.9	22.2	-27	19.5	-27	
Reversed Isolation	1-1000		26		27	26	27	dB
Input Return Loss	1		11		12	10	12	dB
	20		15		12	15	12	
	250		18		12	19	12	
	500		21		12	17	12	
	1000		14		10	10	10	
Output Return Loss	1		11		1	11	1	dB
	20		19		2	21	2	
	250		18		2	21	2	
	500		25		2	21	2	
	1000		11		2	10	2	
Output Power @1dB compression AMP-ON	1		+20.3			+14.2		dBm
	20		+22.4			+16.3		
	250		+24.1			+19.3		
	500		+24.5			+19.5		
	1000		+23.4			+18.3		
Output IP3 (Pout = 0dBm/Tone)	1	—	+38.4			+31.6		dBm
	20	—	+40.3			+33.2		
	250	—	+39.6			+34.4		
	500	+35.4	+39.2			+33		
	1000	—	+36.2			+29.4		
Device Operating Voltage (V _{DD})		+4.75	+5	+5.25	+5	+3	+3	V
Device Operating Current (ID)			142	151	5	72	3	mA
Control Voltage (V _G)			0		+5	0	+5	V
DC Current (ID) Variation Vs. Temperature ²			10			33		uA/degC
DC Current(ID) Variation Vs. Voltage			0.025			0.033		mA/mV
Thermal Resistance			23.3			23.3		degC/W

1. Measured on Mini-Circuits Characterization test board TB-TSS-13LN+. See Characterization Test Circuit (Fig. 1)

2. (Current at 105°C — Current at -45°C)/150

ABSOLUTE MAXIMUM RATINGS³

Parameter	Ratings
Operating Temperature (ground lead)	-40°C to +105°C
Storage Temperature	-65°C to +150°C
Total Power Dissipation	3.3 W
Input Power	+28 dBm (5 minutes max.) +6 dBm (continuous) for 1- 30 MHz +10 dBm (continuous) for 0.03-1 GHz
DC Voltage V _{DD} ⁴ (Pad 7)	+10 V
DC Voltage V _G ⁵ (Pad 1)	+10 V

3. Permanent damage may occur if these limits are exceeded.

4. Measured by keeping V_G=0V.

5. Measured by keeping V_{DD}=5V.

CONTROL VOLTAGE (V_G) FIG. 1

	Min.	Typ.	Max.	Units
Amplifier-ON	—	0	0.7	V
Amplifier-OFF	1.9	5	—	V





ULTRA-HIGH DYNAMIC RANGE, SHUTDOWN

Monolithic Amplifier

TSS-13LN+

Mini-Circuits

50Ω 1 MHz to 1 GHz

SWITCHING SPECIFICATIONS

Parameter		Typ.	Max.	Units
Amplifier ON to Shutdown	OFF TIME (50% Control to 10% RF)	4.8	6.2	μs
	FALL TIME (90 to 10% RF)	7.4	3.6	
Amplifier Shutdown to ON	ON TIME (50% Control to 90% RF)	95.2	144.7	μs
	RISE TIME (10% to 90% RF)	60.0	200.7	
Control Voltage Leakage		482.9	311.0	mV

SIMPLIFIED SCHEMATIC AND PAD DESCRIPTION

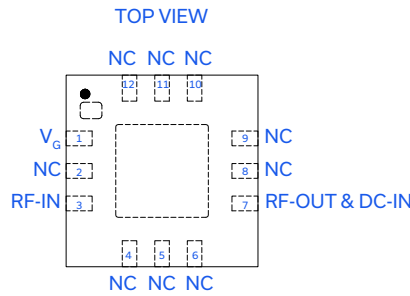
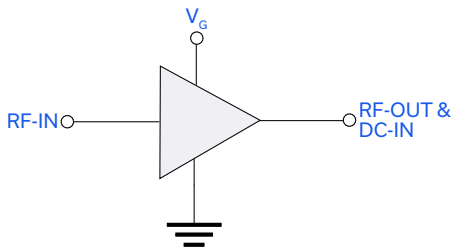

Function	Pad Number	Description
RF-IN	3	RF Input
RF-OUT and DC-IN	7	RF Output and DC Bias
GND	Paddle	Connections to ground.
NC	2, 4-6, 8-12	No connection, grounded externally
V _G	1	Control voltage for shutdown (V _G)



ULTRA-HIGH DYNAMIC RANGE, SHUTDOWN

Monolithic Amplifier

TSS-13LN+

50Ω 1 MHz to 1 GHz

CHARACTERIZATION TEST CIRCUIT / RECOMMENDED APPLICATION CIRCUIT

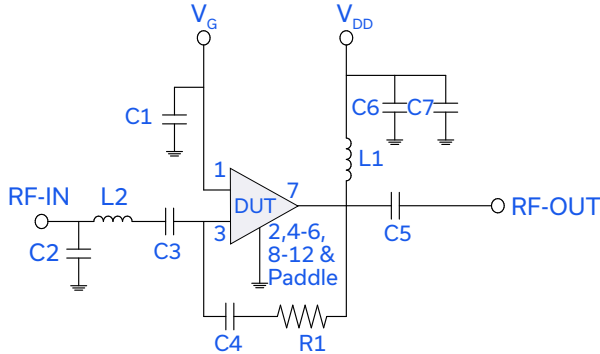

Component	Size	Value	Part Number	Manufacturer
C1	0402	0.1uF	GRM155R71C104KA88D	Murata
C2	0402	1.5pF	GRM1555C1H1R5CA1D	Murata
C3	0603	2.2uF	GRM188C71E225KE11D	Murata
C4	0402	0.1uF	GRM155R71C104KA88D	Murata
C5	0603	2.2uF	GRM188C71E225KE11D	Murata
C6	0402	1000pF	GRM1555C1H102JA01D	Murata
C7	0805	10uF	GRM21BC71E106KE11L	Murata
L1	1210	15uH	LQH32DN150K53L	Murata
L2	0603	5.1nH	0603CS-5N1XJLU	Coilcraft
R1	0402	1.5KOhm	RK73H1ETTP1501F	Koa

Fig 1. Block diagram of Test Circuit used for characterization. (DUT soldered on Mini-Circuits Characterization test board TB-TSS-13LN+)

Gain, Return loss, Output power at 1dB compression (P1dB) , output IP3 (OIP3) and noise figure measured using Agilent's N5242A PNA-X microwave network analyzer.

Conditions:

1. Gain and Return Loss: $P_{IN} = -25\text{dBm}$
2. Output IP3 (OIP3): Two tones, spaced 1 MHz apart, +0dBm/tone at output.
3. Switching Time
 RF Signal: $P_{IN} = -25\text{ dBm}$, $f_{RF} = 500\text{ MHz}$.
 $V_{DD} = 3\text{ \& 5V DC}$, $V_G = \text{Pulse signal at 1 KHz with } V_{HIGH} = 5\text{V, } V_{LOW} = 0\text{V, } 50\% \text{ duty cycle.}$

PRODUCT MARKING



Marking may contain other features or characters for internal lot control





ULTRA-HIGH DYNAMIC RANGE, SHUTDOWN

Monolithic Amplifier

TSS-13LN+

50Ω 1 MHz to 1 GHz

ADDITIONAL DETAILED TECHNICAL INFORMATION IS AVAILABLE ON OUR DASHBOARD. [CLICK HERE](#)

Performance Data	Data Table Swept Graphs S-Parameter (S2P Files) Data Set (.zip file)
Case Style	DQ1225 Plastic package, exposed paddle lead finish: Matte-Tin
Tape & Reel Standard quantities available on reel	F66 7" reels with 20, 50, 100, 200, 500, 1K, or 2K devices
Suggested Layout for PCB Design	PL-623
Evaluation Board	TB-TSS-13LN+
Environmental Ratings	ENV08T9

ESD RATING

Human Body Model (HBM): Class 1A (Pass 250 V) in accordance with ANSI/ESD STM 5.1 - 2001

MSL RATING

Moisture Sensitivity: MSL1 in accordance with IPC/JEDEC J-STD-020D

- NOTES**
- A. Performance and quality attributes and conditions not expressly stated in this specification document are intended to be excluded and do not form a part of this specification document.
 - B. Electrical specifications and performance data contained in this specification document are based on Mini-Circuit's applicable established test performance criteria and measurement instructions.
 - C. The parts covered by this specification document are subject to Mini-Circuits standard limited warranty and terms and conditions (collectively, "Standard Terms"); Purchasers of this part are entitled to the rights and benefits contained therein. For a full statement of the standard terms and the exclusive rights and remedies thereunder, please visit Mini-Circuits' website at www.minicircuits.com/terms/viewterm.html



Typical Performance Data

Definitions:

Input Return Loss = -S11 (dB)

Gain(Power Gain) = S21 (dB)

Reverse Isolation = -S12 (dB)

Output Return Loss = -S22 (dB)

TEST CONDITIONS: Vd = 2.75V, Id = 63mA @ Temperature = +25°C

FREQ	Gain	Isolation	Input Return Loss	Output Return Loss	Stability		IP-3 Output	1dB Comp. Output	Noise Figure
					K	Measure			
(MHz)	(dB)	(dB)	(dB)	(dB)	K	Measure	(dBm)	(dBm)	(dB)
1	23.66	28.72	9.42	10.79	1.09	0.61	30.06	13.37	-
3	24.02	28.16	11.85	20.07	1.08	0.64	30.31	13.38	-
5	23.99	28.01	12.29	24.75	1.07	0.64	30.45	13.45	-
7	23.91	27.68	12.56	26.54	1.06	0.62	30.61	13.55	-
9	23.82	27.54	12.90	26.56	1.05	0.62	30.77	13.79	-
10	23.77	27.33	13.05	26.19	1.04	0.61	30.84	13.84	0.93
20	23.24	26.25	14.73	22.19	1.02	0.55	31.69	15.26	1.06
30	22.86	25.61	16.32	20.72	1.02	0.50	32.37	16.45	0.96
40	22.65	25.36	17.46	20.24	1.02	0.48	32.69	17.44	0.99
50	22.54	25.53	18.04	19.35	1.04	0.47	32.84	17.98	1.03
60	22.44	25.17	18.77	19.77	1.03	0.47	32.95	17.98	1.02
70	22.38	25.03	19.11	19.69	1.03	0.46	33.03	18.11	1.05
80	22.34	25.05	19.40	19.65	1.03	0.46	33.12	18.27	1.05
90	22.31	25.06	19.55	19.69	1.04	0.47	33.15	18.30	1.06
100	22.29	24.98	19.75	19.79	1.04	0.46	33.18	18.39	1.10
150	22.22	24.98	20.03	20.30	1.04	0.47	32.84	18.43	1.11
200	22.16	24.99	19.88	21.17	1.04	0.48	33.19	18.46	1.12
250	22.12	25.12	19.47	22.31	1.05	0.50	32.66	18.57	1.09
300	22.06	25.18	18.91	23.51	1.05	0.52	33.62	18.58	1.10
350	21.99	25.25	18.21	24.30	1.05	0.55	32.69	18.62	1.16
400	21.91	25.30	17.56	24.21	1.05	0.57	31.99	18.51	1.14
450	21.81	25.47	16.88	22.76	1.06	0.60	31.94	18.34	1.12
500	21.67	25.61	16.13	20.60	1.07	0.63	31.30	18.54	1.13
550	21.41	25.88	15.14	18.40	1.08	0.68	30.83	18.10	1.13
600	21.11	26.18	13.50	18.72	1.10	0.74	30.29	18.10	1.15
650	21.24	26.08	13.46	18.13	1.09	0.73	30.35	18.12	1.14
700	21.13	26.09	13.22	16.20	1.08	0.73	30.21	18.14	1.16
750	20.94	26.31	12.83	14.74	1.09	0.76	29.97	17.95	1.14
800	20.72	26.47	12.31	13.52	1.10	0.78	29.70	18.02	1.25
850	20.46	26.64	11.75	12.47	1.11	0.80	29.13	18.00	1.24
900	20.13	26.98	11.09	11.50	1.13	0.83	29.00	17.83	1.22
950	19.71	27.39	10.30	10.58	1.15	0.87	27.92	17.52	1.25
1000	19.10	27.90	9.28	9.77	1.20	0.92	27.69	17.12	1.29
1050	18.20	28.75	7.93	9.41	1.29	1.00	27.17	16.56	1.38
1100	17.69	29.16	6.76	10.67	1.35	1.11	26.71	16.33	1.43
1150	18.04	28.75	6.44	12.23	1.28	1.13	27.53	16.84	1.45
1200	17.99	28.76	6.18	11.58	1.25	1.14	27.39	17.02	1.60

Typical Performance Data

Definitions:

Input Return Loss = -S11 (dB)

Gain(Power Gain) = S21 (dB)

Reverse Isolation = -S12 (dB)

Output Return Loss = -S22 (dB)

TEST CONDITIONS: Vd = 3.00V, Id = 72mA @ Temperature = +25°C

FREQ	Gain	Isolation	Input Return Loss	Output Return Loss	Stability		IP-3 Output	1dB Comp. Output	Noise Figure
					K	Measure			
(MHz)	(dB)	(dB)	(dB)	(dB)	K	Measure	(dBm)	(dBm)	(dB)
1	23.86	28.94	9.63	10.92	1.10	0.62	31.64	14.60	2.92
3	24.22	28.04	12.16	20.79	1.07	0.61	31.90	14.60	1.94
5	24.19	28.07	12.62	26.07	1.07	0.63	32.05	14.66	1.69
7	24.10	27.81	12.89	28.17	1.06	0.62	32.21	14.76	1.51
9	24.00	27.56	13.23	27.70	1.05	0.61	32.37	15.00	1.21
10	23.96	27.42	13.37	26.88	1.04	0.60	32.44	15.05	0.95
20	23.41	26.28	14.96	21.60	1.01	0.53	33.27	16.34	1.05
30	23.03	25.73	16.44	20.06	1.02	0.49	33.87	17.73	0.98
40	22.82	25.45	17.31	19.43	1.02	0.47	34.20	18.49	1.00
50	22.70	25.42	18.11	18.91	1.01	0.46	34.35	19.10	1.01
60	22.60	25.22	18.50	18.98	1.03	0.45	34.46	19.00	1.02
70	22.54	25.23	18.81	18.85	1.03	0.46	34.51	19.10	1.04
80	22.51	25.16	18.97	18.79	1.03	0.45	34.59	19.18	1.04
90	22.47	25.17	19.18	18.86	1.04	0.46	34.64	19.29	1.03
100	22.45	25.14	19.32	18.92	1.04	0.45	34.66	19.38	1.07
150	22.38	25.10	19.63	19.39	1.04	0.46	34.76	19.41	1.10
200	22.33	25.16	19.63	20.12	1.04	0.48	34.06	19.36	1.09
250	22.29	25.15	19.48	21.21	1.04	0.48	34.42	19.56	1.09
300	22.24	25.26	19.18	22.39	1.05	0.51	34.22	19.58	1.08
350	22.17	25.36	18.70	23.36	1.05	0.53	33.99	19.53	1.16
400	22.10	25.46	18.22	23.91	1.06	0.56	33.32	19.51	1.15
450	22.01	25.58	17.63	23.04	1.06	0.59	33.40	19.36	1.12
500	21.88	25.72	17.00	21.17	1.07	0.62	32.98	19.47	1.13
550	21.63	25.99	16.06	18.95	1.08	0.66	32.18	19.03	1.13
600	21.34	26.20	14.25	19.17	1.10	0.72	32.14	19.15	1.14
650	21.47	26.10	14.23	18.88	1.08	0.70	32.15	19.06	1.15
700	21.38	26.22	14.03	16.91	1.09	0.72	31.72	19.10	1.21
750	21.21	26.37	13.64	15.35	1.09	0.74	31.38	18.91	1.16
800	21.00	26.52	13.12	14.07	1.10	0.76	31.30	19.11	1.20
850	20.75	26.78	12.53	12.95	1.11	0.79	30.62	19.12	1.18
900	20.44	27.00	11.85	11.92	1.13	0.81	30.31	18.96	1.22
950	20.03	27.40	11.01	10.95	1.15	0.85	29.53	18.70	1.23
1000	19.43	27.92	9.91	10.08	1.20	0.90	29.28	18.30	1.27
1050	18.55	28.80	8.44	9.65	1.30	0.99	28.66	17.78	1.33
1100	18.02	29.27	7.16	10.88	1.37	1.09	28.14	17.52	1.42
1150	18.39	28.81	6.81	12.60	1.29	1.11	28.94	17.99	1.46
1200	18.37	28.82	6.54	12.01	1.26	1.12	28.80	18.11	1.51

Typical Performance Data

Definitions:

Input Return Loss = -S11 (dB)

Gain(Power Gain) = S21 (dB)

Reverse Isolation = -S12 (dB)

Output Return Loss = -S22 (dB)

TEST CONDITIONS: Vd = 3.25V, Id = 79mA @ Temperature = +25°C

FREQ	Gain	Isolation	Input Return Loss	Output Return Loss	Stability		IP-3 Output	1dB Comp. Output	Noise Figure
					K	Measure			
(MHz)	(dB)	(dB)	(dB)	(dB)			(dBm)	(dBm)	(dB)
1	24.05	28.98	9.84	11.01	1.09	0.60	33.24	15.59	-
3	24.41	28.36	12.51	21.27	1.07	0.62	33.51	15.65	-
5	24.37	28.19	12.94	27.57	1.07	0.62	33.65	15.65	-
7	24.28	27.82	13.22	29.97	1.05	0.60	33.84	15.75	-
9	24.18	27.46	13.53	28.49	1.04	0.58	34.00	15.96	-
10	24.14	27.51	13.69	27.27	1.04	0.59	34.03	16.01	0.96
20	23.53	26.42	15.06	21.16	1.01	0.53	34.83	17.25	1.06
30	23.14	25.86	16.41	19.58	1.02	0.49	35.50	18.44	0.97
40	22.92	25.55	17.22	18.94	1.02	0.47	35.70	19.27	0.99
50	22.81	25.52	17.60	18.41	1.01	0.45	35.88	19.76	1.05
60	22.71	25.37	18.24	18.48	1.03	0.46	35.96	19.75	1.01
70	22.65	25.31	18.51	18.37	1.03	0.45	35.98	19.75	1.05
80	22.61	25.24	18.69	18.32	1.03	0.45	36.08	19.84	1.07
90	22.58	25.22	18.81	18.34	1.03	0.45	36.13	19.94	1.05
100	22.55	25.28	18.99	18.39	1.04	0.46	36.15	20.02	1.08
150	22.49	25.21	19.27	18.83	1.04	0.46	36.02	20.05	1.13
200	22.44	25.29	19.43	19.51	1.04	0.47	35.36	20.00	1.11
250	22.40	25.27	19.41	20.54	1.04	0.48	36.51	20.21	1.10
300	22.35	25.32	19.24	21.65	1.05	0.50	34.56	20.23	1.10
350	22.29	25.43	18.91	22.70	1.05	0.53	34.93	20.18	1.16
400	22.23	25.51	18.59	23.52	1.05	0.55	34.58	20.16	1.11
450	22.13	25.67	18.15	23.10	1.06	0.58	34.31	20.02	1.11
500	22.01	25.78	17.58	21.50	1.07	0.61	33.99	20.15	1.13
550	21.77	25.98	16.68	19.29	1.08	0.65	32.98	19.70	1.15
600	21.49	26.28	14.77	19.46	1.10	0.71	32.79	19.82	1.14
650	21.63	26.18	14.77	19.38	1.08	0.69	33.13	19.73	1.14
700	21.54	26.22	14.60	17.37	1.08	0.70	32.52	19.77	1.21
750	21.38	26.41	14.22	15.79	1.09	0.72	32.42	19.58	1.19
800	21.18	26.56	13.69	14.45	1.10	0.75	32.37	19.69	1.17
850	20.93	26.76	13.10	13.28	1.11	0.77	31.79	19.82	1.21
900	20.63	27.04	12.38	12.21	1.13	0.80	31.40	19.67	1.24
950	20.23	27.40	11.50	11.19	1.15	0.84	30.59	19.43	1.27
1000	19.64	27.98	10.35	10.28	1.20	0.89	30.32	19.04	1.28
1050	18.76	28.80	8.79	9.82	1.30	0.97	29.73	18.53	1.37
1100	18.24	29.28	7.43	11.07	1.37	1.08	29.17	18.29	1.42
1150	18.62	28.88	7.07	12.86	1.30	1.10	29.99	18.63	1.47
1200	18.61	28.80	6.79	12.28	1.25	1.11	29.86	18.87	1.53

Typical Performance Data

Definitions:

Input Return Loss = -S11 (dB)

Gain(Power Gain) = S21 (dB)

Reverse Isolation = -S12 (dB)

Output Return Loss = -S22 (dB)

TEST CONDITIONS: Vd = 4.75V, Id = 132mA @ Temperature = +25°C

FREQ	Gain	Isolation	Input Return Loss	Output Return Loss	Stability		IP-3 Output	1dB Comp. Output	Noise Figure
					K	Measure			
(MHz)	(dB)	(dB)	(dB)	(dB)	K	Measure	(dBm)	(dBm)	(dB)
1	24.63	29.24	10.42	11.20	1.08	0.58	38.06	19.95	-
3	24.96	28.67	13.59	22.35	1.07	0.59	38.37	19.99	-
5	24.93	28.64	14.09	32.48	1.07	0.61	38.54	20.12	-
7	24.83	28.21	14.30	33.65	1.05	0.58	38.73	20.20	-
9	24.72	27.91	14.56	28.26	1.04	0.56	38.93	20.30	-
10	24.67	27.82	14.64	26.29	1.03	0.56	39.01	20.46	1.01
20	24.07	26.70	15.49	19.44	1.01	0.49	39.94	21.88	1.09
30	23.66	26.30	16.11	17.81	1.01	0.47	40.63	22.73	1.02
40	23.43	25.94	16.50	17.22	1.02	0.44	40.83	23.08	1.03
50	23.31	25.90	16.53	16.64	1.01	0.43	41.07	23.53	1.05
60	23.20	25.69	16.92	16.69	1.02	0.42	41.11	23.43	1.03
70	23.14	25.71	17.01	16.59	1.03	0.43	41.19	23.50	1.05
80	23.10	25.62	17.06	16.54	1.03	0.42	41.22	23.58	1.04
90	23.07	25.67	17.15	16.55	1.03	0.43	41.29	23.59	1.06
100	23.04	25.66	17.23	16.59	1.03	0.43	41.30	23.68	1.09
150	22.98	25.62	17.58	16.89	1.04	0.43	40.13	23.71	1.08
200	22.94	25.62	17.92	17.50	1.04	0.44	39.70	23.74	1.11
250	22.92	25.66	18.37	18.34	1.04	0.45	37.81	23.92	1.11
300	22.89	25.71	18.76	19.45	1.04	0.47	38.89	23.94	1.07
350	22.85	25.80	19.15	20.67	1.05	0.49	39.46	24.01	1.15
400	22.81	25.87	19.63	22.41	1.05	0.51	39.70	23.91	1.12
450	22.75	25.97	20.05	24.05	1.06	0.53	38.31	23.83	1.12
500	22.66	26.04	20.40	24.67	1.06	0.55	38.55	24.06	1.12
550	22.46	26.29	20.24	22.84	1.08	0.60	38.09	23.54	1.14
600	22.20	26.59	17.82	22.66	1.10	0.66	38.26	23.69	1.15
650	22.37	26.43	17.83	24.73	1.09	0.63	37.26	23.49	1.14
700	22.32	26.50	18.02	21.85	1.09	0.64	36.83	23.56	1.21
750	22.20	26.62	17.79	19.38	1.10	0.66	36.62	23.35	1.18
800	22.05	26.83	17.30	17.41	1.11	0.68	37.09	23.51	1.19
850	21.85	26.99	16.62	15.76	1.12	0.71	36.48	23.56	1.19
900	21.59	27.32	15.74	14.27	1.14	0.74	36.38	23.46	1.24
950	21.23	27.69	14.58	12.92	1.17	0.78	35.92	23.39	1.25
1000	20.67	28.23	12.99	11.73	1.23	0.83	35.86	23.01	1.27
1050	19.79	29.12	10.89	11.12	1.35	0.92	35.35	22.68	1.35
1100	19.26	29.68	9.10	12.65	1.45	1.02	34.36	22.45	1.38
1150	19.69	29.26	8.57	15.23	1.36	1.04	34.72	22.58	1.45
1200	19.76	29.23	8.25	14.40	1.32	1.04	34.91	22.81	1.50

Typical Performance Data

Definitions:

Input Return Loss = -S11 (dB)

Gain(Power Gain) = S21 (dB)

Reverse Isolation = -S12 (dB)

Output Return Loss = -S22 (dB)

TEST CONDITIONS: Vd = 5.00V, Id = 141mA @ Temperature = +25°C

FREQ	Gain	Isolation	Input Return Loss	Output Return Loss	Stability		IP-3 Output	1dB Comp. Output	Noise Figure
					K	Measure			
(MHz)	(dB)	(dB)	(dB)	(dB)	K	Measure	(dBm)	(dBm)	(dB)
1	24.69	29.23	10.49	11.20	1.08	0.57	38.64	20.51	3.20
3	25.03	28.87	13.71	22.38	1.08	0.61	38.87	20.60	1.99
5	24.99	28.43	14.23	32.65	1.06	0.58	39.06	20.60	1.84
7	24.89	28.13	14.44	33.52	1.04	0.56	39.25	20.69	1.75
9	24.78	27.98	14.69	28.06	1.04	0.56	39.47	20.90	1.61
10	24.73	27.80	14.76	26.23	1.03	0.55	39.57	20.95	1.04
20	24.12	26.82	15.41	19.33	1.01	0.50	40.52	22.44	1.10
30	23.71	26.32	16.13	17.70	1.01	0.47	41.25	23.15	1.04
40	23.48	26.00	16.42	17.12	1.02	0.44	41.61	23.49	1.04
50	23.36	25.91	16.50	16.56	1.03	0.45	41.70	23.95	1.02
60	23.25	25.79	16.75	16.58	1.03	0.43	41.72	23.85	1.02
70	23.19	25.70	16.86	16.47	1.03	0.42	41.85	23.91	1.03
80	23.15	25.77	16.92	16.43	1.03	0.43	41.87	23.99	1.05
90	23.12	25.66	16.95	16.43	1.03	0.42	41.87	24.08	1.07
100	23.09	25.66	17.07	16.48	1.03	0.42	41.92	24.09	1.11
150	23.03	25.65	17.40	16.80	1.04	0.43	39.26	24.20	1.08
200	22.99	25.67	17.74	17.38	1.04	0.44	39.17	24.15	1.11
250	22.97	25.67	18.20	18.23	1.04	0.44	38.24	24.42	1.10
300	22.94	25.77	18.64	19.29	1.05	0.47	40.19	24.45	1.11
350	22.91	25.72	19.09	20.61	1.04	0.47	40.60	24.44	1.15
400	22.87	25.88	19.64	22.37	1.05	0.50	38.60	24.42	1.14
450	22.81	25.94	20.16	24.30	1.06	0.52	39.17	24.26	1.15
500	22.73	26.07	20.63	25.37	1.06	0.55	39.58	24.50	1.15
550	22.53	26.29	20.59	23.64	1.08	0.59	38.63	23.98	1.16
600	22.27	26.57	18.14	23.35	1.10	0.65	37.58	24.13	1.17
650	22.44	26.46	18.17	26.05	1.09	0.62	37.70	24.03	1.13
700	22.40	26.50	18.39	22.74	1.09	0.63	37.46	24.00	1.21
750	22.29	26.63	18.23	20.02	1.10	0.65	37.40	23.80	1.18
800	22.14	26.85	17.72	17.87	1.11	0.68	37.61	23.95	1.19
850	21.94	27.03	17.06	16.12	1.12	0.70	37.26	24.11	1.18
900	21.69	27.32	16.15	14.56	1.14	0.73	37.11	24.02	1.20
950	21.33	27.74	14.96	13.15	1.18	0.78	36.17	23.83	1.21
1000	20.77	28.28	13.30	11.91	1.24	0.83	36.17	23.45	1.26
1050	19.88	29.20	11.13	11.32	1.36	0.92	35.69	23.12	1.36
1100	19.35	29.81	9.29	12.93	1.47	1.02	35.25	22.88	1.40
1150	19.78	29.33	8.75	15.67	1.37	1.03	35.36	23.02	1.45
1200	19.87	29.26	8.41	14.70	1.33	1.03	35.65	23.36	1.53

Typical Performance Data

Definitions:

Input Return Loss = -S11 (dB)

Gain(Power Gain) = S21 (dB)

Reverse Isolation = -S12 (dB)

Output Return Loss = -S22 (dB)

TEST CONDITIONS: Vd = 5.25V, Id = 149mA @ Temperature = +25°C

FREQ	Gain	Isolation	Input Return Loss	Output Return Loss	Stability		IP-3 Output	1dB Comp. Output	Noise Figure
					K	Measure			
(MHz)	(dB)	(dB)	(dB)	(dB)			(dBm)	(dBm)	(dB)
1	24.74	29.13	10.55	11.18	1.07	0.55	39.03	20.85	-
3	25.08	28.64	13.86	22.39	1.06	0.58	39.23	21.01	-
5	25.04	28.47	14.38	32.74	1.06	0.58	39.38	21.05	-
7	24.95	28.27	14.58	33.36	1.05	0.57	39.59	21.13	-
9	24.83	28.03	14.79	27.91	1.04	0.56	39.80	21.22	-
10	24.78	27.82	14.88	26.10	1.03	0.55	39.90	21.26	1.09
20	24.17	26.74	15.46	19.35	1.00	0.48	40.85	23.02	1.12
30	23.75	26.33	16.05	17.60	1.01	0.46	41.60	23.59	1.06
40	23.52	26.01	16.40	17.02	1.02	0.43	41.95	23.92	1.04
50	23.40	25.92	16.53	16.52	1.04	0.43	42.07	24.39	1.05
60	23.29	25.81	16.64	16.50	1.02	0.42	42.21	24.28	1.04
70	23.23	25.77	16.73	16.41	1.03	0.42	42.21	24.35	1.04
80	23.19	25.73	16.84	16.36	1.03	0.42	42.27	24.42	1.07
90	23.16	25.76	16.86	16.36	1.03	0.42	42.27	24.52	1.08
100	23.13	25.66	16.93	16.40	1.03	0.41	42.35	24.53	1.10
150	23.07	25.68	17.27	16.71	1.04	0.42	39.95	24.64	1.13
200	23.04	25.72	17.62	17.29	1.04	0.44	42.28	24.59	1.11
250	23.02	25.77	18.03	18.13	1.04	0.45	41.80	24.86	1.10
300	22.99	25.78	18.54	19.19	1.04	0.46	39.45	24.89	1.11
350	22.96	25.79	19.06	20.52	1.05	0.47	38.75	24.89	1.18
400	22.92	25.94	19.63	22.37	1.05	0.50	37.54	24.88	1.15
450	22.87	25.93	20.22	24.52	1.05	0.51	38.28	24.72	1.12
500	22.79	26.10	20.82	26.05	1.06	0.54	39.27	24.97	1.18
550	22.59	26.30	20.93	24.43	1.08	0.58	38.27	24.44	1.20
600	22.33	26.62	18.43	24.16	1.10	0.64	38.40	24.60	1.20
650	22.51	26.50	18.47	27.54	1.09	0.62	38.20	24.50	1.16
700	22.47	26.58	18.77	23.59	1.09	0.63	37.29	24.48	1.17
750	22.36	26.70	18.63	20.56	1.10	0.65	37.17	24.28	1.22
800	22.21	26.85	18.15	18.24	1.11	0.67	38.02	24.43	1.22
850	22.02	27.10	17.46	16.40	1.13	0.70	37.24	24.59	1.24
900	21.77	27.36	16.53	14.77	1.15	0.73	37.26	24.39	1.22
950	21.41	27.75	15.28	13.30	1.18	0.77	36.96	24.29	1.23
1000	20.84	28.40	13.57	12.06	1.25	0.83	36.12	23.92	1.32
1050	19.94	29.29	11.31	11.48	1.38	0.92	36.11	23.58	1.35
1100	19.43	29.84	9.43	13.27	1.48	1.01	36.14	23.36	1.43
1150	19.88	29.35	8.91	16.12	1.38	1.03	36.02	23.51	1.45
1200	19.97	29.32	8.57	14.87	1.34	1.02	36.11	23.74	1.57

Typical Performance Data

Definitions:

Input Return Loss = -S11 (dB)

Gain(Power Gain) = S21 (dB)

Reverse Isolation = -S12 (dB)

Output Return Loss = -S22 (dB)

TEST CONDITIONS: Vd = 2.75V, Id = 60mA @ Temperature = -45°C

FREQ	Gain	Isolation	Input Return Loss	Output Return Loss	Stability		IP-3 Output	1dB Comp. Output	Noise Figure
					K	Measure			
(MHz)	(dB)	(dB)	(dB)	(dB)	K	Measure	(dBm)	(dBm)	(dB)
1	23.69	28.62	9.33	10.58	1.08	0.60	29.82	13.56	-
3	24.03	28.39	11.79	19.78	1.09	0.66	30.07	13.60	-
5	24.01	27.91	12.26	23.82	1.07	0.63	30.22	13.67	-
7	23.94	27.73	12.60	25.59	1.06	0.62	30.37	13.79	-
9	23.84	27.31	12.89	25.69	1.04	0.60	30.55	14.04	-
10	23.80	27.23	13.08	25.28	1.04	0.59	30.59	14.10	0.71
20	23.27	25.98	15.01	22.40	1.01	0.51	31.47	14.91	0.82
30	22.92	25.69	16.47	21.02	1.02	0.50	32.05	16.27	0.77
40	22.71	25.34	17.52	20.58	1.02	0.47	32.40	17.27	0.76
50	22.59	25.21	18.47	20.17	1.03	0.46	32.55	17.77	0.79
60	22.49	25.11	19.02	20.13	1.03	0.46	32.66	17.96	0.80
70	22.44	25.10	19.43	20.15	1.03	0.46	32.75	18.02	0.84
80	22.40	25.02	19.72	20.19	1.03	0.45	32.81	18.03	0.93
90	22.38	25.04	19.97	20.25	1.04	0.46	32.86	18.16	0.92
100	22.36	25.01	20.14	20.32	1.04	0.45	32.86	18.15	0.89
150	22.29	25.00	20.59	21.03	1.04	0.46	32.84	18.23	0.91
200	22.25	25.04	20.58	21.89	1.04	0.48	32.86	18.24	0.90
250	22.21	25.00	20.25	23.15	1.04	0.48	32.92	18.24	0.86
300	22.17	25.16	19.83	24.22	1.05	0.51	32.34	18.28	0.85
350	22.11	25.17	19.16	25.05	1.05	0.52	32.26	18.22	0.88
400	22.04	25.27	18.65	25.17	1.05	0.54	31.77	18.19	0.93
450	21.96	25.43	17.97	23.66	1.06	0.57	31.38	17.89	0.90
500	21.84	25.54	17.24	21.50	1.06	0.60	31.16	17.77	0.90
550	21.64	25.74	16.45	18.97	1.07	0.64	30.52	17.58	0.87
600	21.18	26.21	14.30	18.21	1.10	0.73	29.89	17.36	0.90
650	21.43	25.98	14.28	19.30	1.08	0.69	30.01	17.60	0.91
700	21.37	26.07	14.22	17.00	1.08	0.70	29.88	17.43	0.91
750	21.22	26.16	13.83	15.40	1.08	0.72	29.46	17.42	0.91
800	21.03	26.35	13.35	14.12	1.09	0.74	29.14	17.29	1.00
850	20.80	26.59	12.75	12.99	1.10	0.77	28.88	17.01	0.91
900	20.52	26.81	12.08	11.94	1.11	0.79	28.11	16.74	0.96
950	20.17	27.14	11.29	10.93	1.13	0.82	28.18	16.76	1.04
1000	19.65	27.64	10.29	9.95	1.17	0.87	27.68	16.57	1.00
1050	18.78	28.46	8.89	9.12	1.25	0.94	26.50	15.76	1.03
1100	17.68	29.57	7.18	9.60	1.41	1.06	25.58	14.49	1.10
1150	18.15	29.04	6.60	12.65	1.33	1.13	26.76	15.59	1.12
1200	18.50	28.56	6.58	12.73	1.23	1.12	26.93	16.12	1.24

Typical Performance Data

Definitions:

Input Return Loss = -S11 (dB)

Gain(Power Gain) = S21 (dB)

Reverse Isolation = -S12 (dB)

Output Return Loss = -S22 (dB)

TEST CONDITIONS: Vd = 3.00V, Id = 69mA @ Temperature = -45°C

FREQ	Gain	Isolation	Input Return Loss	Output Return Loss	Stability		IP-3 Output	1dB Comp. Output	Noise Figure
					K	Measure			
(MHz)	(dB)	(dB)	(dB)	(dB)			(dBm)	(dBm)	(dB)
1	23.87	28.94	9.51	10.74	1.09	0.61	31.32	14.79	-
3	24.22	28.23	12.06	20.46	1.08	0.63	31.60	14.89	-
5	24.19	28.10	12.55	25.16	1.07	0.63	31.75	14.97	-
7	24.12	27.75	12.88	27.48	1.05	0.61	31.90	15.08	-
9	24.02	27.53	13.18	27.02	1.04	0.60	32.05	15.21	-
10	23.97	27.37	13.35	26.21	1.04	0.59	32.12	15.27	0.70
20	23.46	26.39	15.17	21.62	1.02	0.53	32.97	16.09	0.81
30	23.10	25.76	16.50	20.32	1.02	0.49	33.54	17.46	0.75
40	22.89	25.52	17.46	19.70	1.02	0.47	33.79	18.45	0.76
50	22.77	25.41	17.91	19.53	1.01	0.46	33.98	18.83	0.83
60	22.67	25.19	18.62	19.23	1.03	0.44	34.08	18.99	0.78
70	22.62	25.20	18.96	19.26	1.03	0.45	34.14	19.03	0.82
80	22.58	25.22	19.25	19.23	1.03	0.45	34.21	19.02	0.91
90	22.56	25.12	19.47	19.34	1.03	0.44	34.23	19.16	0.93
100	22.54	25.15	19.61	19.41	1.03	0.45	34.25	19.14	0.88
150	22.47	25.14	20.20	20.04	1.04	0.45	33.71	19.14	0.92
200	22.43	25.14	20.34	20.78	1.04	0.46	34.26	19.15	0.92
250	22.40	25.25	20.32	21.81	1.04	0.48	34.83	19.24	0.87
300	22.36	25.27	20.06	22.86	1.05	0.49	33.24	19.30	0.85
350	22.31	25.35	19.65	23.92	1.05	0.51	32.99	19.25	0.85
400	22.25	25.44	19.35	24.81	1.05	0.53	33.61	19.22	0.90
450	22.17	25.54	18.89	24.16	1.06	0.56	32.66	18.91	0.87
500	22.07	25.66	18.32	22.39	1.06	0.58	32.69	18.70	0.89
550	21.88	25.82	17.62	19.80	1.07	0.62	32.13	18.65	0.86
600	21.43	26.27	15.27	18.81	1.10	0.71	31.44	18.45	0.89
650	21.69	26.04	15.23	20.38	1.08	0.67	31.45	18.68	0.91
700	21.64	26.12	15.19	17.97	1.08	0.68	31.27	18.52	0.93
750	21.50	26.27	14.81	16.23	1.09	0.70	30.70	18.40	0.89
800	21.32	26.40	14.33	14.82	1.09	0.72	30.52	18.54	0.96
850	21.11	26.58	13.73	13.57	1.10	0.74	30.21	18.31	0.91
900	20.85	26.87	13.05	12.45	1.12	0.77	29.39	18.06	1.00
950	20.51	27.22	12.19	11.38	1.14	0.80	29.58	18.08	0.98
1000	20.00	27.73	11.08	10.33	1.18	0.85	29.31	17.77	1.00
1050	19.14	28.52	9.52	9.44	1.26	0.92	28.13	17.11	1.01
1100	18.05	29.59	7.64	9.87	1.41	1.05	27.22	15.88	1.08
1150	18.53	29.06	7.02	13.06	1.33	1.11	28.19	16.95	1.14
1200	18.90	28.70	7.01	13.26	1.25	1.10	28.42	17.38	1.18

Typical Performance Data

Definitions:

Input Return Loss = -S11 (dB)

Gain(Power Gain) = S21 (dB)

Reverse Isolation = -S12 (dB)

Output Return Loss = -S22 (dB)

TEST CONDITIONS: Vd = 3.25V, Id = 78mA @ Temperature = -45°C

FREQ	Gain	Isolation	Input Return Loss	Output Return Loss	Stability		IP-3 Output	1dB Comp. Output	Noise Figure
					K	Measure			
(MHz)	(dB)	(dB)	(dB)	(dB)			(dBm)	(dBm)	(dB)
1	24.07	28.85	9.69	10.80	1.08	0.59	32.97	15.98	-
3	24.40	28.47	12.39	20.86	1.08	0.63	33.24	16.07	-
5	24.38	27.97	12.91	26.39	1.06	0.60	33.39	16.10	-
7	24.30	27.86	13.23	28.70	1.05	0.60	33.54	16.22	-
9	24.20	27.65	13.49	27.60	1.04	0.59	33.69	16.43	-
10	24.15	27.44	13.69	26.58	1.04	0.58	33.77	16.49	0.68
20	23.59	26.31	15.28	21.46	1.01	0.51	34.60	17.15	0.82
30	23.22	25.96	16.53	19.81	1.02	0.49	35.12	18.52	0.72
40	23.01	25.59	17.36	19.30	1.02	0.46	35.33	19.48	0.72
50	22.89	25.77	17.74	18.86	1.03	0.44	35.50	19.82	0.85
60	22.79	25.37	18.37	18.75	1.03	0.45	35.60	19.88	0.82
70	22.74	25.27	18.70	18.77	1.03	0.44	35.65	19.90	0.81
80	22.69	25.27	18.92	18.77	1.03	0.44	35.68	19.97	0.88
90	22.68	25.27	19.14	18.83	1.03	0.44	35.68	20.02	0.92
100	22.66	25.21	19.28	18.93	1.03	0.44	35.70	20.00	0.90
150	22.59	25.24	19.87	19.49	1.04	0.45	35.45	19.99	0.92
200	22.55	25.25	20.13	20.19	1.04	0.46	35.27	20.10	0.94
250	22.52	25.21	20.29	21.22	1.04	0.46	35.40	20.12	0.88
300	22.49	25.33	20.22	22.29	1.04	0.48	35.44	20.26	0.85
350	22.45	25.35	19.99	23.57	1.05	0.49	33.76	20.23	0.89
400	22.39	25.49	19.93	24.86	1.05	0.52	34.20	20.10	0.91
450	22.33	25.57	19.67	24.86	1.06	0.54	33.83	19.79	0.91
500	22.23	25.70	19.25	23.44	1.06	0.57	33.34	19.70	0.91
550	22.05	25.94	18.66	20.69	1.07	0.61	32.98	19.68	0.87
600	21.61	26.34	16.11	19.46	1.10	0.69	32.08	19.49	0.93
650	21.87	26.12	16.05	21.59	1.08	0.66	32.18	19.59	0.92
700	21.84	26.18	16.12	18.95	1.08	0.66	32.11	19.45	0.92
750	21.71	26.33	15.74	17.01	1.09	0.68	31.61	19.33	0.95
800	21.54	26.43	15.25	15.48	1.09	0.70	31.28	19.49	0.96
850	21.34	26.65	14.63	14.13	1.10	0.72	31.38	19.41	0.92
900	21.09	26.92	13.91	12.92	1.12	0.75	30.68	19.18	0.87
950	20.76	27.26	12.98	11.78	1.14	0.79	30.70	19.08	0.87
1000	20.27	27.72	11.79	10.67	1.18	0.83	30.52	18.92	0.91
1050	19.42	28.59	10.10	9.72	1.27	0.90	29.55	18.27	1.01
1100	18.32	29.67	8.08	10.16	1.43	1.03	28.47	17.06	1.04
1150	18.81	29.18	7.41	13.57	1.35	1.09	29.43	17.97	1.11
1200	19.21	28.78	7.40	13.83	1.27	1.08	29.44	18.55	1.19

Typical Performance Data

Definitions:

Input Return Loss = -S11 (dB)

Gain(Power Gain) = S21 (dB)

Reverse Isolation = -S12 (dB)

Output Return Loss = -S22 (dB)

TEST CONDITIONS: Vd = 4.75V, Id = 129mA @ Temperature = -45°C

FREQ	Gain	Isolation	Input Return Loss	Output Return Loss	Stability		IP-3 Output	1dB Comp. Output	Noise Figure
					K	Measure			
(MHz)	(dB)	(dB)	(dB)	(dB)			(dBm)	(dBm)	(dB)
1	24.66	28.89	10.27	10.91	1.06	0.53	37.08	20.22	-
3	24.99	28.43	13.53	21.51	1.06	0.56	37.42	20.30	-
5	24.95	28.27	14.09	27.87	1.05	0.56	37.66	20.33	-
7	24.87	28.06	14.43	30.09	1.04	0.56	37.85	20.42	-
9	24.75	27.62	14.61	27.40	1.03	0.52	38.08	20.65	-
10	24.70	27.66	14.75	25.95	1.03	0.53	38.18	20.69	0.85
20	24.10	26.69	15.83	20.16	1.01	0.48	39.45	21.66	0.84
30	23.70	26.09	16.39	18.52	1.01	0.44	40.38	22.77	0.79
40	23.47	25.94	16.83	18.01	1.02	0.44	40.72	23.40	0.77
50	23.35	25.93	16.78	17.66	1.01	0.43	40.90	23.58	0.83
60	23.24	25.63	17.20	17.48	1.02	0.41	40.95	23.60	0.81
70	23.19	25.55	17.40	17.49	1.02	0.40	41.03	23.52	0.81
80	23.14	25.58	17.54	17.46	1.03	0.41	41.07	23.55	0.90
90	23.13	25.54	17.66	17.53	1.03	0.41	41.12	23.72	0.93
100	23.11	25.61	17.74	17.56	1.03	0.42	40.99	23.59	0.89
150	23.05	25.51	18.28	18.08	1.03	0.41	39.30	23.58	0.93
200	23.02	25.54	18.75	18.68	1.04	0.42	37.04	23.73	0.93
250	23.00	25.57	19.15	19.59	1.04	0.43	37.72	23.86	0.84
300	22.98	25.59	19.67	20.64	1.04	0.44	39.36	23.95	0.86
350	22.96	25.68	20.11	22.11	1.04	0.46	37.35	23.95	0.87
400	22.93	25.70	20.83	24.37	1.05	0.47	39.60	23.91	0.94
450	22.90	25.82	21.56	27.34	1.05	0.49	38.04	23.62	0.90
500	22.83	25.90	22.30	31.09	1.06	0.51	36.71	23.46	0.91
550	22.69	26.11	22.98	28.15	1.07	0.55	37.07	23.63	0.87
600	22.26	26.52	19.74	24.69	1.11	0.64	37.62	23.46	0.91
650	22.55	26.33	19.47	33.41	1.08	0.59	36.78	23.54	0.91
700	22.56	26.39	20.00	25.18	1.08	0.60	36.95	23.32	0.94
750	22.48	26.52	19.97	21.34	1.09	0.61	35.70	23.09	0.92
800	22.35	26.70	19.56	18.79	1.10	0.64	36.02	23.29	0.97
850	22.18	26.88	18.88	16.77	1.11	0.66	36.59	23.47	0.93
900	21.97	27.11	17.92	15.07	1.13	0.69	36.32	23.37	0.91
950	21.68	27.46	16.64	13.52	1.16	0.72	36.25	23.27	0.97
1000	21.21	27.99	14.91	12.11	1.21	0.77	35.90	23.44	0.98
1050	20.33	28.93	12.52	11.01	1.32	0.86	35.27	22.86	1.00
1100	19.18	30.09	9.87	11.83	1.54	0.99	35.66	21.94	1.07
1150	19.72	29.65	8.98	17.12	1.45	1.03	35.18	22.18	1.12
1200	20.22	29.20	8.96	16.75	1.34	1.01	35.35	22.89	1.20

Typical Performance Data

Definitions:

Input Return Loss = -S11 (dB)

Gain(Power Gain) = S21 (dB)

Reverse Isolation = -S12 (dB)

Output Return Loss = -S22 (dB)

TEST CONDITIONS: Vd = 5.00V, Id = 138mA @ Temperature = -45°C

FREQ	Gain	Isolation	Input Return Loss	Output Return Loss	Stability		IP-3 Output	1dB Comp. Output	Noise Figure
					K	Measure			
(MHz)	(dB)	(dB)	(dB)	(dB)			(dBm)	(dBm)	(dB)
1	24.72	28.94	10.32	10.89	1.07	0.53	37.93	20.81	-
3	25.05	28.55	13.64	21.45	1.06	0.57	38.25	20.89	-
5	25.02	28.25	14.23	27.95	1.05	0.55	38.48	20.89	-
7	24.93	28.02	14.55	29.82	1.04	0.54	38.66	21.00	-
9	24.81	27.85	14.74	27.25	1.03	0.54	38.92	21.22	-
10	24.76	27.66	14.89	25.82	1.02	0.53	39.04	21.27	0.85
20	24.16	26.68	15.85	20.03	1.01	0.48	40.38	22.28	0.84
30	23.76	26.07	16.37	18.51	1.01	0.43	41.41	23.32	0.79
40	23.52	25.97	16.78	17.97	1.02	0.43	41.78	23.94	0.77
50	23.40	25.78	17.02	17.53	1.02	0.41	41.90	24.04	0.83
60	23.29	25.63	17.11	17.45	1.02	0.40	42.07	24.05	0.81
70	23.24	25.66	17.27	17.45	1.03	0.41	42.00	23.97	0.81
80	23.19	25.60	17.39	17.42	1.03	0.41	42.14	24.00	0.90
90	23.17	25.67	17.54	17.47	1.03	0.42	42.08	24.17	0.93
100	23.15	25.61	17.64	17.55	1.03	0.41	42.02	24.05	0.89
150	23.10	25.57	18.11	18.04	1.03	0.41	42.48	24.11	0.93
200	23.07	25.56	18.58	18.64	1.04	0.42	43.20	24.19	0.93
250	23.05	25.53	19.09	19.55	1.04	0.42	36.78	24.32	0.84
300	23.03	25.62	19.53	20.57	1.04	0.44	42.43	24.50	0.86
350	23.02	25.68	20.02	22.07	1.04	0.45	39.01	24.50	0.87
400	22.99	25.77	20.77	24.30	1.05	0.47	36.62	24.47	0.94
450	22.95	25.87	21.55	27.64	1.05	0.49	38.61	24.09	0.90
500	22.89	25.96	22.43	33.37	1.06	0.51	39.61	24.03	0.91
550	22.75	26.12	23.30	30.81	1.07	0.55	39.88	24.22	0.87
600	22.32	26.58	20.06	26.30	1.11	0.64	39.18	24.05	0.91
650	22.61	26.38	19.74	37.30	1.09	0.59	37.65	24.13	0.91
700	22.63	26.35	20.37	25.77	1.08	0.59	37.60	23.92	0.94
750	22.55	26.53	20.37	21.73	1.09	0.61	37.03	23.69	0.92
800	22.42	26.68	19.98	19.04	1.10	0.63	37.87	23.90	0.97
850	22.26	26.88	19.26	16.95	1.11	0.65	37.32	24.08	0.93
900	22.05	27.19	18.31	15.20	1.13	0.68	36.60	23.99	0.91
950	21.76	27.51	16.95	13.62	1.16	0.72	38.16	23.88	0.97
1000	21.28	28.06	15.15	12.20	1.21	0.77	37.63	24.06	0.98
1050	20.40	28.96	12.70	11.15	1.33	0.85	37.01	23.59	1.00
1100	19.23	30.21	10.02	12.12	1.57	0.99	36.87	22.67	1.07
1150	19.78	29.75	9.10	17.94	1.47	1.03	36.80	22.89	1.12
1200	20.29	29.24	9.08	16.95	1.34	1.00	36.30	23.51	1.20

Typical Performance Data

Definitions:

Input Return Loss = -S11 (dB)

Gain(Power Gain) = S21 (dB)

Reverse Isolation = -S12 (dB)

Output Return Loss = -S22 (dB)

TEST CONDITIONS: Vd = 5.25V, Id = 146mA @ Temperature = -45°C

FREQ	Gain	Isolation	Input Return Loss	Output Return Loss	Stability		IP-3 Output	1dB Comp. Output	Noise Figure
					K	Measure			
(MHz)	(dB)	(dB)	(dB)	(dB)			(dBm)	(dBm)	(dB)
1	24.78	28.84	10.35	10.88	1.06	0.51	38.78	21.35	-
3	25.11	28.68	13.78	21.46	1.07	0.57	39.19	21.42	-
5	25.07	28.31	14.37	27.80	1.05	0.55	39.45	21.41	-
7	24.98	28.01	14.71	29.59	1.04	0.53	39.68	21.24	-
9	24.87	27.83	14.87	27.03	1.03	0.53	39.91	21.49	-
10	24.81	27.66	14.99	25.68	1.02	0.52	40.03	21.54	0.86
20	24.20	26.87	15.93	19.85	1.01	0.49	41.32	22.82	0.85
30	23.80	26.14	16.39	18.40	1.01	0.43	42.34	23.72	0.77
40	23.56	26.02	16.67	17.80	1.02	0.43	42.84	24.35	0.76
50	23.43	25.94	16.96	17.64	1.01	0.42	42.93	24.53	0.86
60	23.33	25.71	17.00	17.34	1.02	0.41	43.04	24.46	0.80
70	23.27	25.70	17.15	17.34	1.03	0.41	43.10	24.38	0.82
80	23.23	25.70	17.24	17.32	1.03	0.42	43.19	24.49	0.89
90	23.21	25.55	17.41	17.41	1.03	0.40	43.08	24.58	0.93
100	23.19	25.65	17.49	17.43	1.03	0.41	43.12	24.53	0.92
150	23.13	25.55	17.95	17.92	1.03	0.41	42.53	24.52	0.94
200	23.10	25.59	18.43	18.51	1.04	0.42	41.34	24.68	0.91
250	23.09	25.68	18.85	19.35	1.04	0.43	40.03	24.82	0.87
300	23.07	25.68	19.34	20.37	1.04	0.44	40.82	24.92	0.85
350	23.05	25.78	19.88	21.84	1.05	0.46	38.00	24.93	0.85
400	23.03	25.77	20.65	24.02	1.05	0.47	38.14	24.89	0.92
450	22.99	25.87	21.44	27.30	1.05	0.49	41.00	24.60	0.88
500	22.93	25.97	22.38	33.51	1.06	0.51	40.01	24.46	0.87
550	22.79	26.17	23.40	32.31	1.07	0.55	39.41	24.66	0.87
600	22.37	26.60	20.20	26.97	1.11	0.63	40.41	24.49	0.90
650	22.66	26.43	19.85	39.21	1.09	0.59	39.58	24.67	0.93
700	22.68	26.41	20.47	26.22	1.08	0.59	39.78	24.47	0.91
750	22.60	26.60	20.52	21.98	1.09	0.61	38.23	24.24	0.89
800	22.47	26.74	20.18	19.24	1.10	0.63	39.46	24.45	0.97
850	22.31	26.89	19.49	17.10	1.11	0.65	39.05	24.65	0.90
900	22.10	27.15	18.47	15.33	1.13	0.68	39.07	24.44	0.94
950	21.81	27.57	17.11	13.73	1.16	0.72	38.42	24.34	1.01
1000	21.33	28.08	15.28	12.29	1.21	0.77	39.94	24.62	0.98
1050	20.44	29.01	12.79	11.25	1.34	0.85	39.26	24.05	1.02
1100	19.27	30.26	10.09	12.30	1.58	0.99	39.82	23.25	1.08
1150	19.82	29.77	9.17	18.38	1.48	1.03	38.25	23.34	1.10
1200	20.34	29.30	9.14	17.09	1.35	1.00	38.26	24.07	1.21

Typical Performance Data

Definitions:

Input Return Loss = -S11 (dB)

Gain(Power Gain) = S21 (dB)

Reverse Isolation = -S12 (dB)

Output Return Loss = -S22 (dB)

TEST CONDITIONS: Vd = 2.75V, Id = 64mA @ Temperature = +105°C

FREQ	Gain	Isolation	Input Return Loss	Output Return Loss	Stability		IP-3 Output	1dB Comp. Output	Noise Figure
					K	Measure			
(MHz)	(dB)	(dB)	(dB)	(dB)			(dBm)	(dBm)	(dB)
1	23.43	28.64	9.29	10.93	1.10	0.63	29.42	13.91	-
3	23.74	27.99	11.44	19.80	1.08	0.65	29.63	13.75	-
5	23.72	27.92	11.86	23.10	1.08	0.66	29.78	14.06	-
7	23.65	27.62	12.19	24.63	1.07	0.64	29.94	14.00	-
9	23.55	27.34	12.49	24.81	1.05	0.63	30.12	14.14	-
10	23.51	27.17	12.69	24.57	1.05	0.62	30.21	14.19	1.20
20	22.99	26.05	14.58	22.80	1.02	0.55	31.13	14.95	1.33
30	22.64	25.50	16.25	21.65	1.02	0.52	31.80	16.22	1.27
40	22.43	25.21	17.49	21.23	1.03	0.49	32.15	17.19	1.27
50	22.32	25.13	18.55	21.16	1.02	0.48	32.40	17.58	1.35
60	22.22	24.94	19.12	20.83	1.03	0.47	32.54	17.75	1.33
70	22.17	24.91	19.56	20.83	1.04	0.47	32.67	17.90	1.37
80	22.12	24.95	19.81	20.82	1.04	0.48	32.75	17.91	1.45
90	22.10	24.83	20.11	20.96	1.04	0.47	32.80	18.05	1.38
100	22.08	24.85	20.20	21.01	1.04	0.47	32.86	17.95	1.41
150	22.00	24.82	20.47	21.64	1.04	0.48	33.67	18.02	1.44
200	21.95	24.92	20.10	22.57	1.05	0.50	33.73	18.16	1.42
250	21.90	25.03	19.49	24.11	1.05	0.52	32.92	18.25	1.40
300	21.84	25.08	18.72	25.60	1.06	0.54	32.46	18.31	1.42
350	21.77	25.16	17.89	26.39	1.06	0.56	32.06	18.36	1.44
400	21.67	25.23	17.10	25.66	1.06	0.59	31.56	18.22	1.46
450	21.56	25.39	16.25	23.29	1.07	0.62	31.53	18.03	1.46
500	21.40	25.58	15.42	20.78	1.08	0.65	31.52	17.89	1.46
550	21.14	25.84	14.39	18.67	1.09	0.70	30.62	17.98	1.46
600	20.89	26.09	13.06	18.92	1.11	0.76	30.38	17.94	1.49
650	20.94	26.06	12.88	17.77	1.10	0.75	30.43	17.97	1.51
700	20.82	26.12	12.58	15.88	1.10	0.76	30.08	17.90	1.52
750	20.62	26.30	12.11	14.45	1.10	0.78	29.67	17.74	1.53
800	20.38	26.53	11.63	13.27	1.12	0.80	29.42	17.85	1.55
850	20.09	26.75	11.06	12.26	1.13	0.83	29.20	17.85	1.55
900	19.75	27.07	10.42	11.34	1.15	0.86	28.49	17.69	1.58
950	19.31	27.48	9.66	10.54	1.18	0.90	28.49	17.48	1.60
1000	18.72	28.03	8.73	9.88	1.24	0.95	28.06	17.13	1.68
1050	17.94	28.72	7.63	9.72	1.32	1.02	27.20	16.58	1.76
1100	17.46	29.16	6.67	10.65	1.39	1.11	26.81	16.40	1.85
1150	17.54	28.96	6.24	11.64	1.34	1.14	27.42	16.61	1.91
1200	17.44	29.05	5.86	11.16	1.32	1.16	27.16	16.84	2.03

Typical Performance Data

Definitions:

Input Return Loss = -S11 (dB)

Gain(Power Gain) = S21 (dB)

Reverse Isolation = -S12 (dB)

Output Return Loss = -S22 (dB)

TEST CONDITIONS: Vd = 3.00V, Id = 73mA @ Temperature = +105°C

FREQ	Gain	Isolation	Input Return Loss	Output Return Loss	Stability		IP-3 Output	1dB Comp. Output	Noise Figure
					K	Measure			
(MHz)	(dB)	(dB)	(dB)	(dB)			(dBm)	(dBm)	(dB)
1	23.63	28.64	9.50	11.06	1.09	0.62	30.85	14.77	-
3	23.94	28.25	11.77	20.46	1.09	0.66	31.09	14.91	-
5	23.91	27.79	12.19	24.32	1.07	0.63	31.24	14.92	-
7	23.84	27.63	12.52	26.01	1.06	0.63	31.40	15.03	-
9	23.74	27.35	12.80	25.94	1.05	0.61	31.59	15.29	-
10	23.70	27.25	13.00	25.55	1.04	0.61	31.66	15.33	1.21
20	23.16	26.29	14.79	22.18	1.02	0.56	32.56	16.02	1.34
30	22.81	25.58	16.39	21.02	1.02	0.50	33.21	17.37	1.28
40	22.60	25.34	17.47	20.49	1.03	0.49	33.53	18.23	1.27
50	22.48	25.18	18.02	20.37	1.03	0.47	33.76	18.59	1.35
60	22.38	25.12	18.81	19.95	1.03	0.47	33.91	18.75	1.34
70	22.32	25.07	19.23	19.92	1.04	0.47	34.02	18.79	1.38
80	22.28	25.03	19.46	19.88	1.04	0.47	34.10	18.87	1.49
90	22.26	24.96	19.68	19.99	1.04	0.46	34.16	18.93	1.38
100	22.23	24.97	19.79	20.05	1.04	0.46	34.21	18.91	1.44
150	22.16	25.01	20.13	20.55	1.04	0.48	34.52	18.98	1.48
200	22.10	25.04	19.94	21.38	1.05	0.49	34.68	19.03	1.44
250	22.06	25.18	19.58	22.72	1.05	0.52	34.89	19.13	1.39
300	22.01	25.15	19.04	24.29	1.05	0.53	33.78	19.29	1.45
350	21.94	25.28	18.37	25.57	1.06	0.55	33.32	19.25	1.45
400	21.86	25.40	17.73	25.98	1.06	0.58	32.73	19.21	1.48
450	21.75	25.50	16.99	24.19	1.07	0.61	33.02	18.93	1.47
500	21.60	25.64	16.19	21.77	1.07	0.64	32.84	18.80	1.45
550	21.35	25.95	15.13	19.46	1.09	0.69	32.15	19.00	1.44
600	21.11	26.16	13.73	19.70	1.11	0.74	31.86	18.87	1.50
650	21.17	26.12	13.54	18.67	1.10	0.73	31.70	18.90	1.54
700	21.06	26.21	13.26	16.63	1.10	0.74	31.46	18.83	1.55
750	20.87	26.40	12.80	15.09	1.11	0.76	31.08	18.69	1.55
800	20.64	26.62	12.31	13.86	1.12	0.79	30.77	18.81	1.54
850	20.37	26.87	11.69	12.77	1.14	0.82	30.35	18.84	1.54
900	20.03	27.14	11.02	11.79	1.16	0.85	29.80	18.68	1.53
950	19.61	27.54	10.22	10.93	1.19	0.89	29.85	18.48	1.61
1000	19.03	28.08	9.22	10.24	1.24	0.94	29.53	18.27	1.67
1050	18.27	28.76	8.05	10.03	1.33	1.01	28.59	17.74	1.75
1100	17.79	29.24	7.02	10.96	1.39	1.09	28.24	17.45	1.84
1150	17.87	29.08	6.55	12.01	1.35	1.13	28.72	17.75	1.90
1200	17.78	29.11	6.15	11.57	1.32	1.14	28.58	17.89	2.03

Typical Performance Data

Definitions:

Input Return Loss = -S11 (dB)

Gain(Power Gain) = S21 (dB)

Reverse Isolation = -S12 (dB)

Output Return Loss = -S22 (dB)

TEST CONDITIONS: Vd = 3.25V, Id = 81mA @ Temperature = +105°C

FREQ	Gain	Isolation	Input Return Loss	Output Return Loss	Stability		IP-3 Output	1dB Comp. Output	Noise Figure
					K	Measure			
(MHz)	(dB)	(dB)	(dB)	(dB)			(dBm)	(dBm)	(dB)
1	23.83	28.76	9.72	11.20	1.09	0.61	32.37	15.86	-
3	24.12	28.41	12.11	21.00	1.09	0.66	32.58	16.00	-
5	24.10	28.10	12.53	25.77	1.07	0.64	32.73	16.02	-
7	24.03	27.74	12.86	27.75	1.06	0.62	32.87	16.13	-
9	23.93	27.57	13.12	27.00	1.05	0.62	33.07	16.37	-
10	23.88	27.41	13.31	26.29	1.04	0.60	33.09	16.42	1.25
20	23.31	26.30	15.02	21.92	1.02	0.54	33.99	17.06	1.35
30	22.95	25.78	16.43	20.38	1.02	0.51	34.61	18.29	1.29
40	22.74	25.50	17.42	19.80	1.03	0.49	34.94	19.19	1.28
50	22.62	25.36	18.23	19.48	1.01	0.47	35.12	19.46	1.35
60	22.51	25.24	18.57	19.22	1.03	0.47	35.27	19.59	1.33
70	22.46	25.22	18.89	19.21	1.04	0.47	35.37	19.62	1.39
80	22.41	25.14	19.03	19.15	1.04	0.46	35.43	19.62	1.49
90	22.40	25.12	19.29	19.21	1.04	0.46	35.50	19.75	1.42
100	22.37	25.15	19.40	19.27	1.04	0.47	35.55	19.65	1.43
150	22.30	25.07	19.71	19.74	1.04	0.47	36.65	19.73	1.50
200	22.24	25.13	19.69	20.50	1.05	0.48	35.32	19.87	1.43
250	22.20	25.28	19.54	21.76	1.05	0.51	34.47	19.97	1.42
300	22.15	25.24	19.18	23.23	1.05	0.52	35.40	20.04	1.40
350	22.09	25.40	18.73	24.77	1.06	0.55	34.44	20.02	1.44
400	22.01	25.47	18.24	25.88	1.06	0.57	34.12	19.97	1.48
450	21.92	25.65	17.60	24.71	1.07	0.60	34.75	19.78	1.43
500	21.78	25.78	16.87	22.59	1.08	0.63	34.04	19.65	1.47
550	21.54	26.02	15.83	20.14	1.09	0.68	33.35	19.78	1.46
600	21.30	26.28	14.35	20.33	1.11	0.73	33.23	19.64	1.49
650	21.37	26.15	14.15	19.49	1.10	0.71	32.96	19.67	1.53
700	21.27	26.33	13.90	17.35	1.10	0.73	32.39	19.62	1.52
750	21.09	26.47	13.43	15.70	1.11	0.75	32.07	19.47	1.54
800	20.87	26.68	12.92	14.37	1.12	0.78	31.86	19.60	1.54
850	20.61	26.93	12.29	13.22	1.14	0.80	31.74	19.66	1.58
900	20.29	27.20	11.59	12.17	1.16	0.83	30.90	19.51	1.60
950	19.87	27.55	10.73	11.28	1.19	0.87	31.11	19.31	1.73
1000	19.30	28.10	9.68	10.53	1.24	0.92	30.79	19.12	1.69
1050	18.55	28.84	8.43	10.29	1.33	1.00	29.87	18.60	1.74
1100	18.07	29.23	7.33	11.24	1.39	1.08	29.50	18.31	1.82
1150	18.16	29.19	6.83	12.35	1.37	1.12	29.88	18.60	1.92
1200	18.08	29.20	6.42	11.94	1.34	1.13	29.94	18.76	2.01

Typical Performance Data

Definitions:

Input Return Loss = -S11 (dB)

Gain(Power Gain) = S21 (dB)

Reverse Isolation = -S12 (dB)

Output Return Loss = -S22 (dB)

TEST CONDITIONS: Vd = 4.75V, Id = 131mA @ Temperature = +105°C

FREQ	Gain	Isolation	Input Return Loss	Output Return Loss	Stability		IP-3 Output	1dB Comp. Output	Noise Figure
					K	Measure			
(MHz)	(dB)	(dB)	(dB)	(dB)	K	Measure	(dBm)	(dBm)	(dB)
1	24.38	28.98	10.44	11.40	1.08	0.58	36.41	20.07	-
3	24.67	28.61	13.25	22.33	1.08	0.62	36.52	19.98	-
5	24.64	28.58	13.72	29.82	1.08	0.63	36.73	20.06	-
7	24.56	27.97	14.04	31.97	1.05	0.58	36.81	20.16	-
9	24.45	27.84	14.25	28.31	1.04	0.58	37.03	20.40	-
10	24.40	27.73	14.38	26.62	1.04	0.58	37.03	20.43	1.30
20	23.82	26.92	15.53	20.15	1.02	0.55	37.96	21.23	1.40
30	23.43	26.06	16.29	18.74	1.01	0.47	38.63	22.05	1.36
40	23.21	25.90	16.75	17.99	1.02	0.47	39.06	22.64	1.29
50	23.08	25.88	17.15	17.76	1.01	0.45	39.22	22.88	1.38
60	22.98	25.62	17.21	17.45	1.03	0.45	39.44	22.93	1.37
70	22.93	25.63	17.35	17.43	1.03	0.45	39.47	22.95	1.41
80	22.88	25.60	17.41	17.35	1.04	0.45	39.54	23.02	1.53
90	22.86	25.51	17.56	17.41	1.03	0.44	39.65	23.13	1.46
100	22.83	25.56	17.62	17.43	1.04	0.45	39.70	23.05	1.49
150	22.76	25.51	17.90	17.77	1.04	0.45	40.80	23.14	1.56
200	22.72	25.53	18.20	18.38	1.04	0.46	40.82	23.29	1.50
250	22.69	25.61	18.54	19.37	1.05	0.48	37.22	23.40	1.45
300	22.66	25.63	18.92	20.69	1.05	0.49	37.86	23.51	1.49
350	22.62	25.72	19.21	22.41	1.06	0.51	39.25	23.50	1.50
400	22.57	25.77	19.45	24.83	1.06	0.53	36.52	23.56	1.49
450	22.50	25.88	19.57	27.24	1.07	0.55	37.67	23.29	1.51
500	22.39	26.02	19.47	27.92	1.08	0.58	37.65	23.21	1.50
550	22.19	26.26	18.87	24.97	1.09	0.63	38.19	23.33	1.47
600	21.98	26.51	16.98	25.43	1.11	0.67	37.98	23.21	1.51
650	22.07	26.44	16.87	25.25	1.10	0.66	37.51	23.27	1.53
700	22.02	26.57	16.79	21.60	1.11	0.67	37.28	23.14	1.56
750	21.88	26.68	16.36	19.00	1.11	0.69	36.23	23.00	1.56
800	21.70	26.89	15.84	17.04	1.13	0.72	36.54	23.02	1.61
850	21.48	27.14	15.09	15.43	1.15	0.75	36.30	22.99	1.62
900	21.20	27.46	14.23	14.03	1.17	0.78	35.73	22.84	1.62
950	20.82	27.87	13.13	12.86	1.21	0.82	35.78	22.69	1.61
1000	20.27	28.43	11.77	11.91	1.28	0.87	35.29	22.60	1.65
1050	19.52	29.17	10.15	11.66	1.38	0.95	34.94	22.11	1.76
1100	19.05	29.60	8.76	12.87	1.46	1.03	34.42	21.73	1.85
1150	19.17	29.46	8.11	14.38	1.41	1.06	34.75	22.02	1.97
1200	19.16	29.55	7.62	13.69	1.39	1.07	35.21	22.24	2.07

Typical Performance Data

Definitions:

Input Return Loss = -S11 (dB)

Gain(Power Gain) = S21 (dB)

Reverse Isolation = -S12 (dB)

Output Return Loss = -S22 (dB)

TEST CONDITIONS: Vd = 5.00V, Id = 138mA @ Temperature = +105°C

FREQ	Gain	Isolation	Input Return Loss	Output Return Loss	Stability		IP-3 Output	1dB Comp. Output	Noise Figure
					K	Measure			
(MHz)	(dB)	(dB)	(dB)	(dB)	K	Measure	(dBm)	(dBm)	(dB)
1	24.43	29.07	10.50	11.40	1.08	0.58	36.58	20.31	-
3	24.72	28.51	13.41	22.38	1.07	0.60	36.72	20.52	-
5	24.69	28.43	13.87	29.90	1.07	0.61	36.91	20.52	-
7	24.61	28.30	14.21	32.02	1.06	0.61	37.02	20.62	-
9	24.50	27.90	14.40	28.30	1.04	0.58	37.26	20.85	-
10	24.45	27.72	14.54	26.51	1.04	0.57	37.34	20.90	1.30
20	23.86	26.67	15.54	20.27	1.01	0.51	38.17	21.69	1.38
30	23.48	26.18	16.26	18.63	1.02	0.48	38.93	22.48	1.28
40	23.25	25.96	16.65	17.96	1.02	0.47	39.31	23.12	1.33
50	23.13	25.83	16.83	17.50	1.03	0.46	39.59	23.30	1.38
60	23.02	25.71	17.04	17.35	1.03	0.45	39.73	23.35	1.40
70	22.97	25.67	17.19	17.29	1.03	0.45	39.81	23.37	1.40
80	22.92	25.63	17.21	17.28	1.04	0.45	39.96	23.43	1.50
90	22.90	25.60	17.34	17.29	1.04	0.44	40.02	23.55	1.44
100	22.88	25.57	17.41	17.33	1.04	0.44	40.12	23.46	1.46
150	22.81	25.60	17.72	17.64	1.04	0.45	39.96	23.56	1.51
200	22.76	25.61	18.01	18.24	1.05	0.46	39.57	23.71	1.47
250	22.74	25.57	18.36	19.27	1.05	0.47	38.03	23.82	1.44
300	22.71	25.73	18.77	20.53	1.05	0.50	40.85	23.93	1.48
350	22.67	25.76	19.10	22.35	1.06	0.51	37.30	23.92	1.49
400	22.62	25.86	19.48	24.73	1.06	0.53	37.42	23.89	1.53
450	22.56	25.90	19.68	27.49	1.07	0.55	39.62	23.70	1.48
500	22.45	26.03	19.71	28.87	1.07	0.57	39.90	23.64	1.50
550	22.25	26.27	19.14	25.88	1.09	0.62	37.79	23.74	1.47
600	22.04	26.55	17.25	26.47	1.11	0.67	38.76	23.63	1.55
650	22.14	26.51	17.12	26.36	1.11	0.66	37.40	23.70	1.54
700	22.09	26.58	17.07	22.18	1.11	0.67	37.50	23.56	1.57
750	21.96	26.71	16.69	19.43	1.12	0.69	36.54	23.32	1.57
800	21.78	26.92	16.17	17.36	1.13	0.71	36.00	23.45	1.58
850	21.56	27.23	15.41	15.69	1.15	0.74	36.76	23.41	1.64
900	21.28	27.49	14.52	14.24	1.18	0.77	36.29	23.15	1.62
950	20.90	27.90	13.41	13.03	1.21	0.82	36.06	23.12	1.75
1000	20.36	28.44	12.00	12.08	1.28	0.87	36.07	22.91	1.72
1050	19.61	29.19	10.34	11.82	1.39	0.95	35.46	22.41	1.77
1100	19.14	29.72	8.92	13.11	1.48	1.03	35.11	22.14	1.87
1150	19.26	29.58	8.25	14.67	1.43	1.06	35.39	22.44	1.93
1200	19.25	29.65	7.74	13.88	1.41	1.07	35.15	22.56	2.00

Typical Performance Data

Definitions:

Input Return Loss = -S11 (dB)

Gain(Power Gain) = S21 (dB)

Reverse Isolation = -S12 (dB)

Output Return Loss = -S22 (dB)

TEST CONDITIONS: Vd = 5.25V, Id = 146mA @ Temperature = +105°C

FREQ	Gain	Isolation	Input Return Loss	Output Return Loss	Stability		IP-3 Output	1dB Comp. Output	Noise Figure
					K	Measure			
(MHz)	(dB)	(dB)	(dB)	(dB)			(dBm)	(dBm)	(dB)
1	24.47	29.23	10.60	11.38	1.09	0.59	36.57	20.46	-
3	24.76	28.71	13.58	22.46	1.08	0.62	36.85	20.61	-
5	24.73	28.44	14.04	29.86	1.07	0.60	37.13	20.61	-
7	24.65	28.13	14.37	31.83	1.05	0.59	37.21	20.78	-
9	24.54	27.91	14.53	28.12	1.04	0.58	37.41	20.90	-
10	24.49	27.74	14.67	26.41	1.04	0.57	37.51	20.95	1.29
20	23.90	26.73	15.68	20.18	1.02	0.51	38.40	22.20	1.41
30	23.52	26.26	16.18	18.49	1.02	0.49	39.13	22.95	1.33
40	23.29	25.99	16.58	17.93	1.02	0.47	39.58	23.51	1.30
50	23.16	25.85	16.96	17.45	1.03	0.45	39.78	23.67	1.42
60	23.06	25.73	16.92	17.31	1.03	0.45	39.98	23.79	1.41
70	23.00	25.70	17.01	17.27	1.03	0.45	40.13	23.74	1.42
80	22.96	25.56	17.05	17.24	1.03	0.43	40.28	23.81	1.52
90	22.94	25.65	17.19	17.24	1.04	0.45	40.34	23.92	1.44
100	22.91	25.61	17.27	17.29	1.04	0.44	40.40	23.84	1.50
150	22.84	25.61	17.51	17.62	1.04	0.45	40.47	23.94	1.52
200	22.80	25.64	17.84	18.20	1.05	0.46	37.40	24.08	1.47
250	22.77	25.58	18.21	19.20	1.04	0.46	39.53	24.19	1.46
300	22.75	25.70	18.67	20.47	1.05	0.49	40.77	24.31	1.45
350	22.71	25.71	19.06	22.30	1.05	0.50	35.84	24.37	1.49
400	22.67	25.87	19.46	24.83	1.06	0.53	40.05	24.35	1.51
450	22.60	25.96	19.76	27.96	1.07	0.55	40.32	24.09	1.49
500	22.50	26.10	19.84	30.37	1.08	0.57	37.80	24.03	1.51
550	22.30	26.32	19.44	27.22	1.09	0.62	38.51	24.12	1.51
600	22.10	26.56	17.52	27.86	1.11	0.66	38.67	24.01	1.53
650	22.20	26.52	17.39	27.63	1.11	0.65	38.69	24.08	1.56
700	22.15	26.55	17.36	22.76	1.10	0.66	37.52	23.95	1.58
750	22.03	26.73	16.98	19.82	1.12	0.68	37.84	23.71	1.56
800	21.85	26.97	16.48	17.63	1.13	0.71	36.79	23.84	1.56
850	21.64	27.21	15.71	15.92	1.15	0.74	37.41	23.78	1.67
900	21.36	27.53	14.79	14.44	1.18	0.77	36.37	23.52	1.61
950	20.98	27.96	13.64	13.17	1.22	0.81	37.21	23.49	1.64
1000	20.44	28.51	12.19	12.23	1.28	0.87	36.50	23.27	1.71
1050	19.68	29.26	10.50	12.01	1.40	0.95	35.66	22.77	1.79
1100	19.21	29.83	9.05	13.39	1.50	1.03	36.12	22.40	1.87
1150	19.34	29.67	8.36	14.98	1.45	1.05	35.95	22.71	1.96
1200	19.33	29.70	7.85	14.04	1.42	1.06	35.94	22.94	2.06

Typical Performance Curves

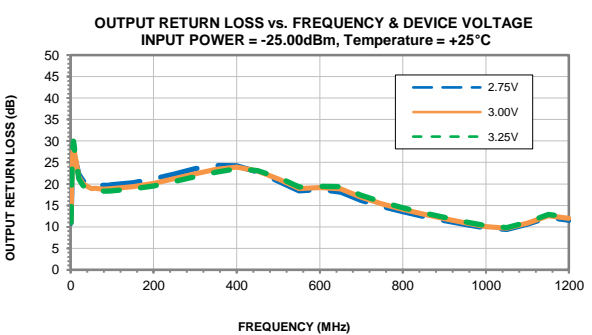
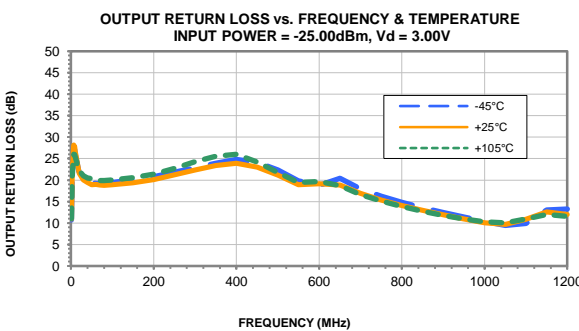
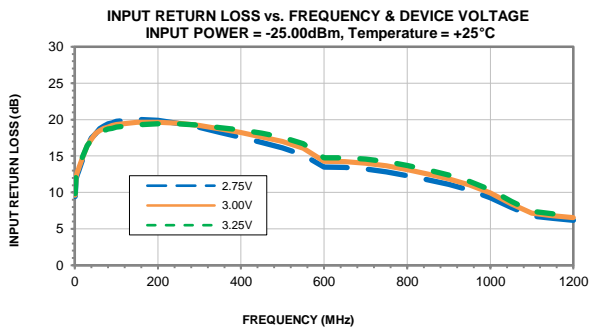
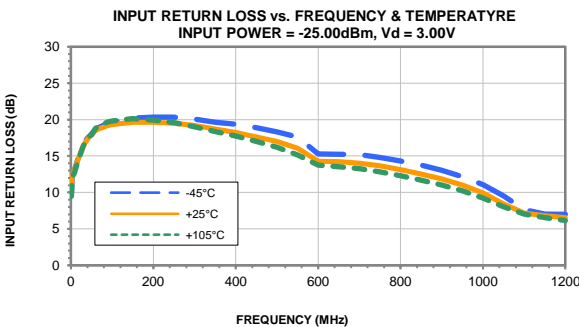
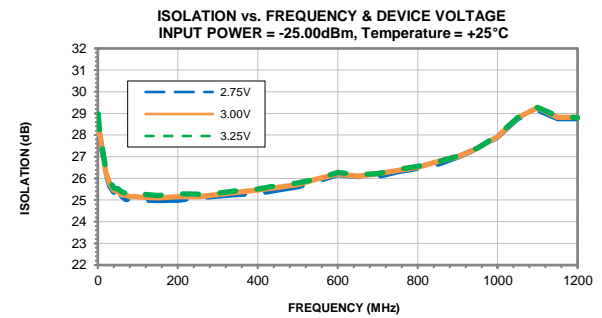
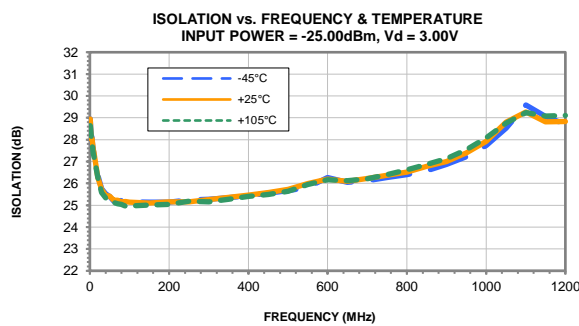
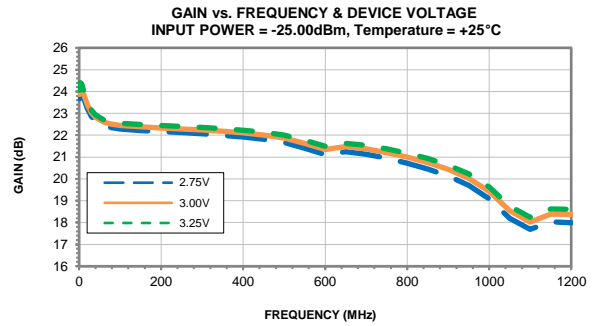
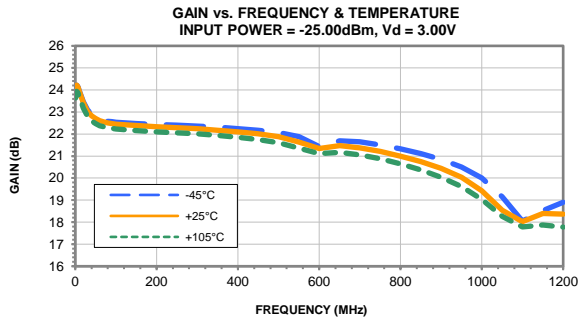

Typical Performance Curves

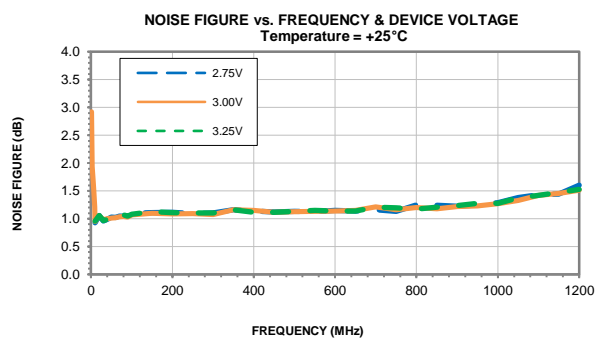
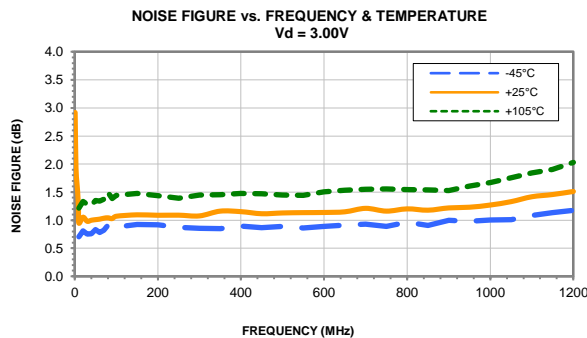
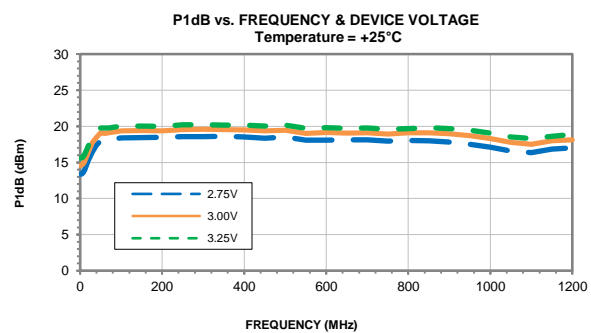
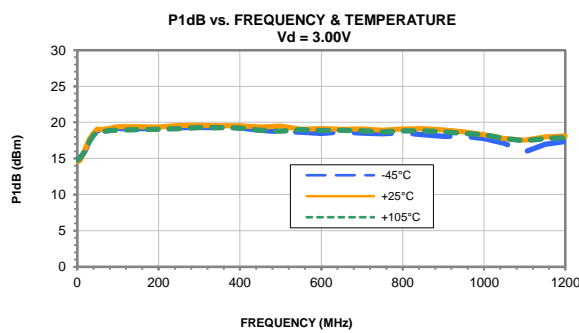
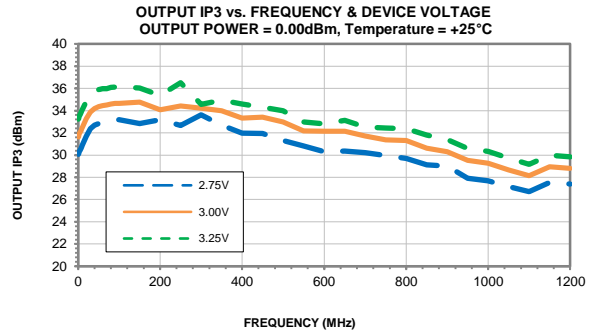
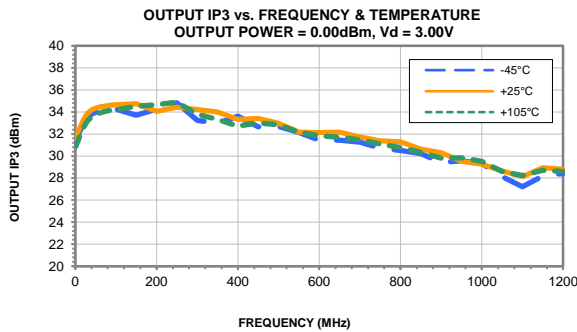

Typical Performance Curves

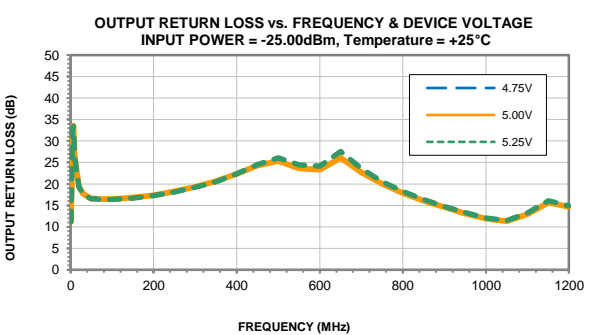
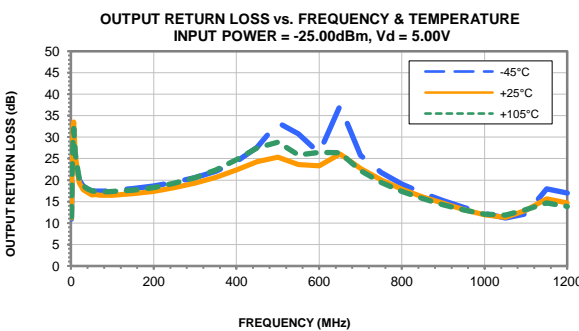
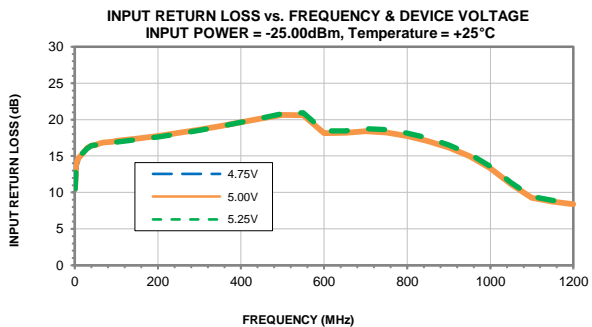
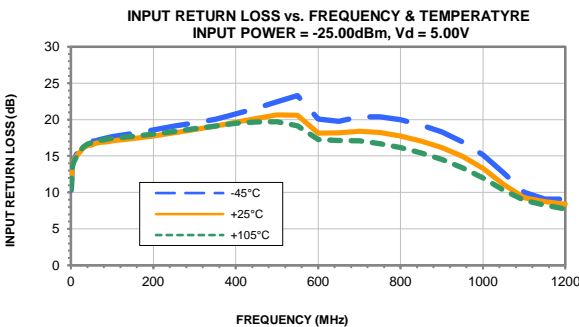
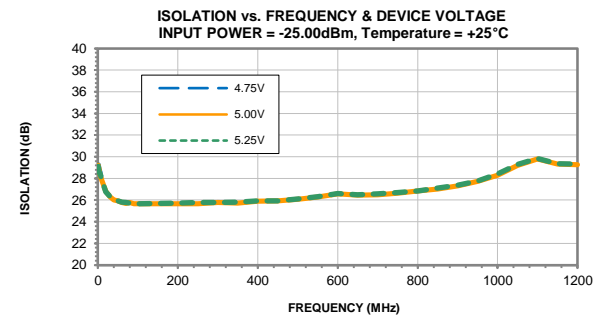
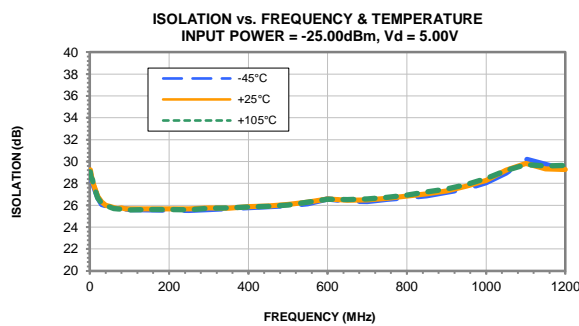
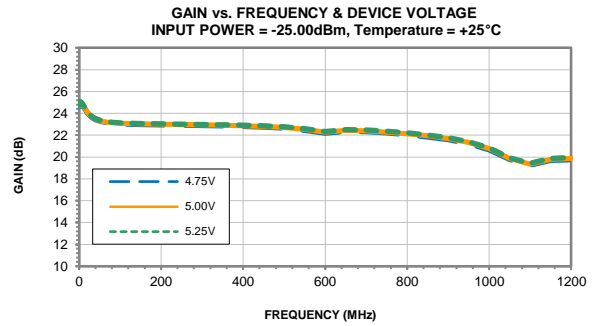
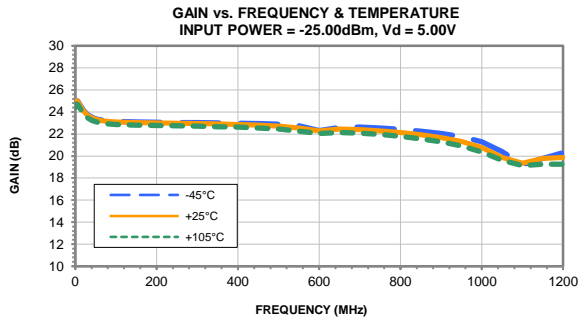

Typical Performance Curves

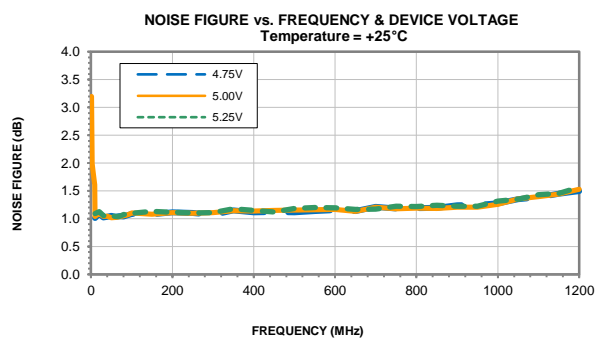
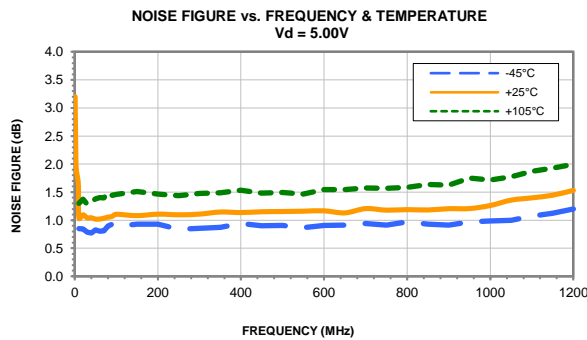
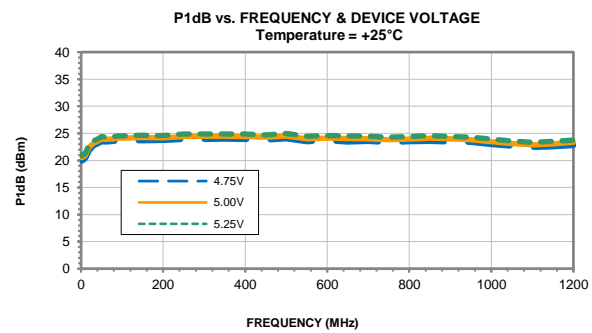
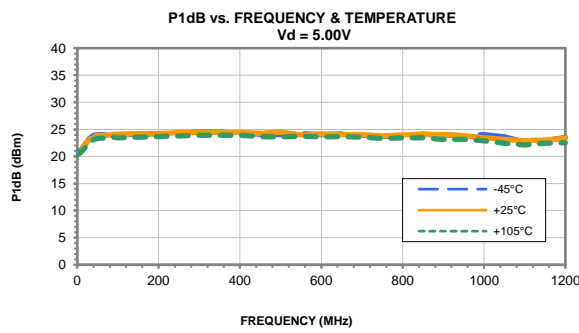
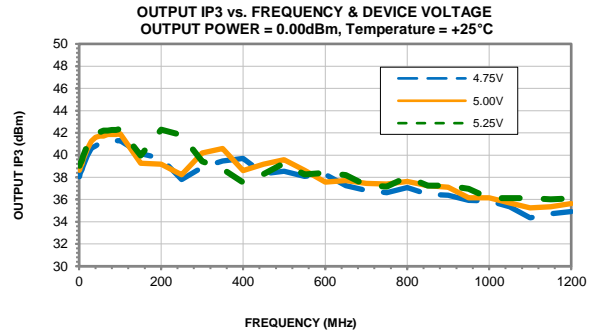
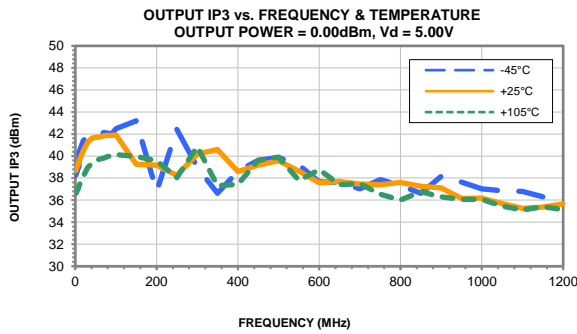

Outline Dimensions

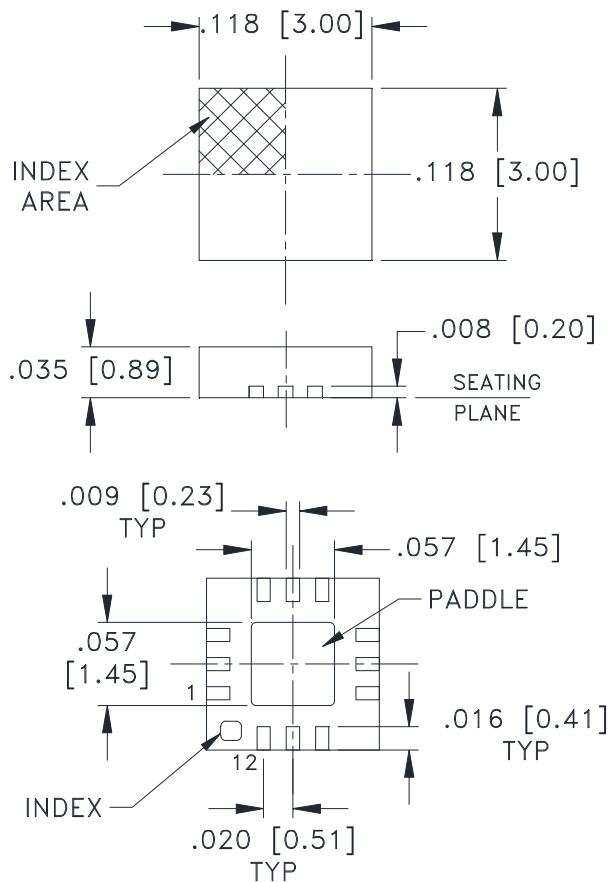

PCB Land Pattern

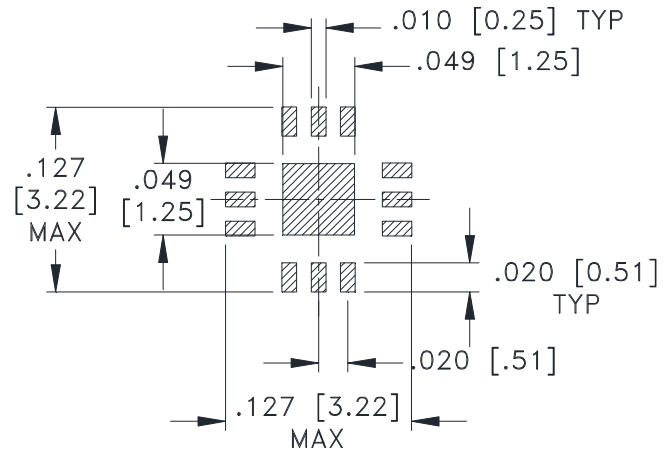

SUGGESTED LAYOUT,
TOLERANCE TO BE WITHIN $\pm .002$

Weight: .02 Grams

Dimensions are in inches (mm). Tolerances: 2Pl. $\pm .01$; 3 Pl. $\pm .004$

Notes:

1. Case material: Plastic.
2. Termination finish:
 - For RoHS Case Styles: Tin-Silver alloy plate over Nickel barrier or Matte-Tin. All models, (+) suffix. See Data sheet.
 - For RoHS-5 Case Styles: Tin-Lead plate. All models, no (+) suffix.

Mini-Circuits®

Distribution Centers NORTH AMERICA 800-654-7949 • 417-335-5935 • Fax 417-335-5945 • EUROPE 44-1252-832600 • Fax 44-1252-837010

Mini-Circuits ISO 9001 & ISO 14001 Certified

INTERNET <http://www.minicircuits.com>

P.O. Box 350166, Brooklyn, New York 11235-0003 (718) 934-4500 Fax (718) 332-4661

Tape & Reel Packaging TR-F66

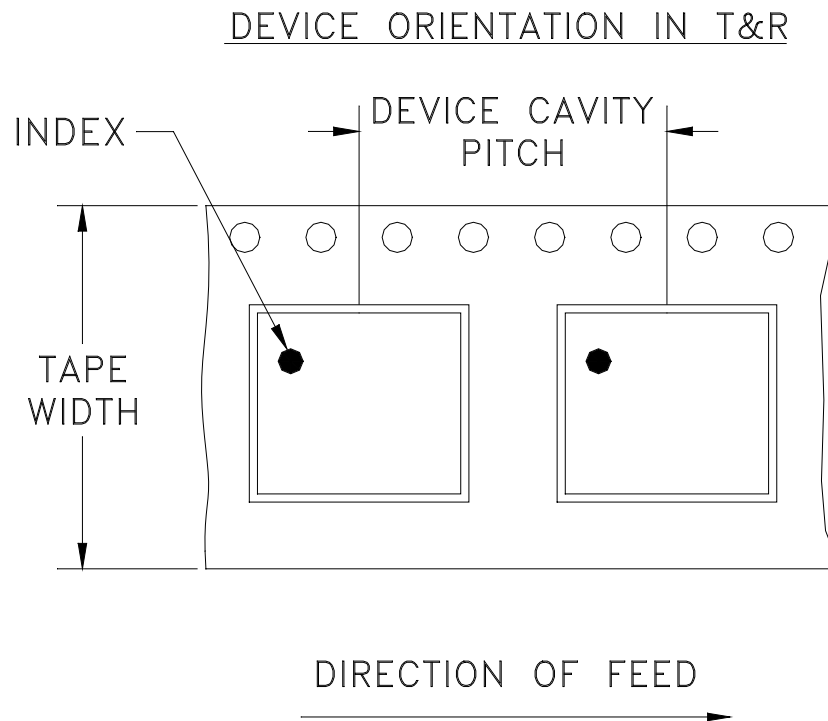

Tape Width, mm	Device Cavity Pitch, mm	Reel Size, inches	Devices per Reel see note	
8	4	7	Small quantity standard	20
				50
				100
				200
				500
		7	Standard	1000, 2000, 3000

Note: Please consult individual model data sheet to determine device per reel availability.

Mini-Circuits carrier tape materials provide protection from ESD (Electro-Static Discharge) during handling and transportation. Tapes are static dissipative and comply with industry standards EIA-481/EIA-541.

Go to: www.minicircuits.com/pages/pdfs/tape.pdf

Mini-Circuits®

INTERNET <http://www.minicircuits.com>

P.O. Box 350166, Brooklyn, New York 11235-0003 (718) 934-4500 Fax (718) 332-4661

Distribution Centers NORTH AMERICA 800-654-7949 • 417-335-5935 • Fax 417-335-5945 • EUROPE 44-1252-832600 • Fax 44-1252-837010

Mini-Circuits ISO 9001 & ISO 14001 Certified

THIRD ANGLE PROJECTION

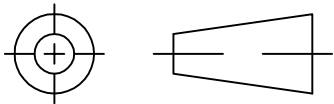

REVISIONS

REV	ECN No.	DESCRIPTION	DATE	DR	AUTH
OR	M172056	NEW RELEASE	01/18/19	NP	GH

SUGGESTED MOUNTING CONFIGURATION FOR
DQ1225 CASE STYLE, "12AM05" PIN CODE

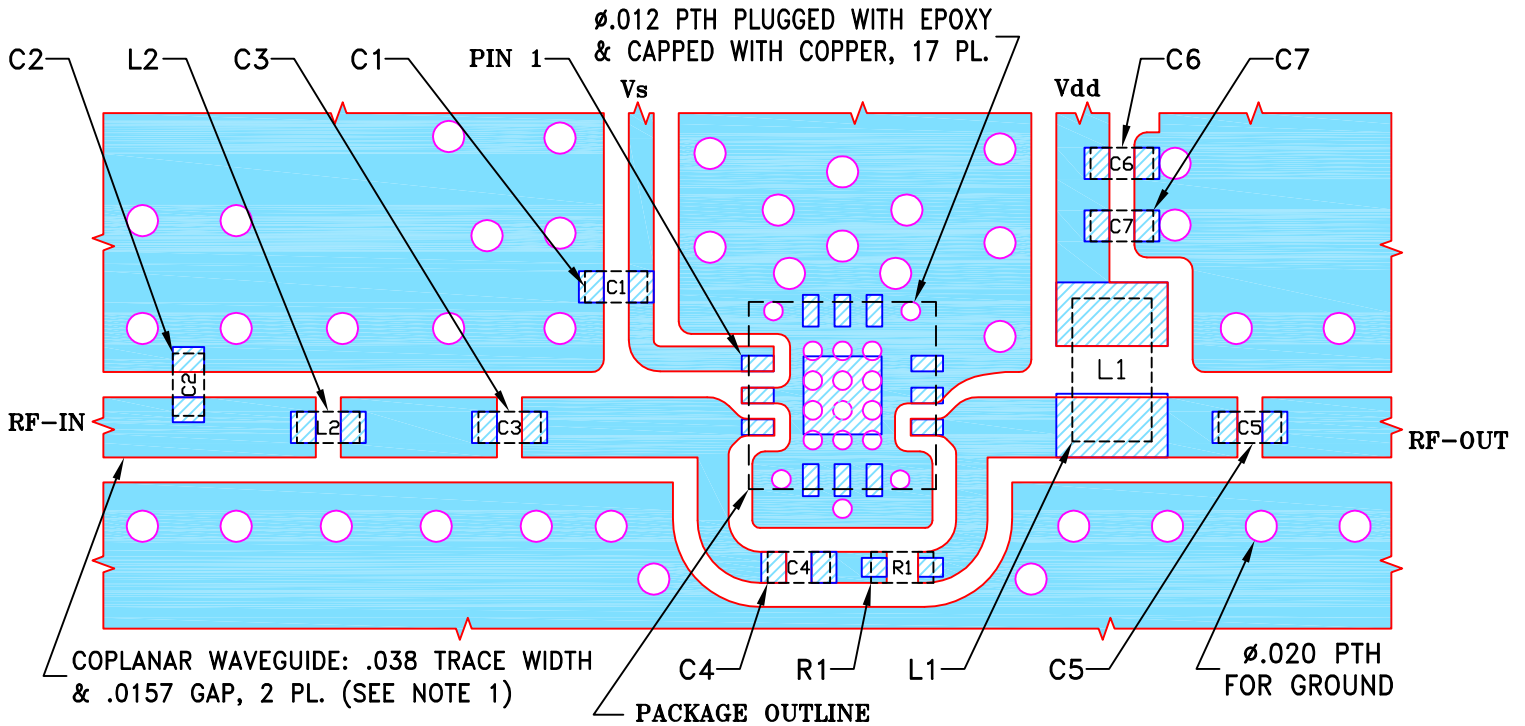

COMPONENT	SIZE
C1...C7;L2;R1	0402
L1	0805

NOTES:

1. TRACE WIDTH & GAP PARAMETERS ARE SHOWN FOR ROGERS R04350B WITH DIELECTRIC THICKNESS .020"±.0015"; COPPER: 1/2 OZ. EACH SIDE. FOR OTHER MATERIALS TRACE WIDTH AND GAP MAY NEED TO BE MODIFIED.
2. CHIP COMPONENT FOOTPRINTS SHOWN FOR REFERENCE. FOR COMPONENT VALUES REFER TO TB-TSS-13LN+ OR TB-TSS-13HLN+.
3. BOTTOM SIDE OF THE PCB IS CONTINUOUS GROUND PLANE.



DENOTES PCB COPPER LAYOUT WITH SMOBC (SOLDER MASK OVER BARE COPPER)



DENOTES COPPER LAND PATTERN FREE OF SOLDER MASK

UNLESS OTHERWISE SPECIFIED	INITIALS	DATE
DRAWN	NP	01/18/19
CHECKED	GF	01/18/19
APPROVED	GH	01/18/19

Mini-Circuits®
THIS DOCUMENT AND ITS CONTENTS ARE THE PROPERTY OF MINI-CIRCUITS. EXCEPT FOR USE EXPRESSLY GRANTED, IN WRITING, TO ITS VENDORS, VENDEE AND THE UNITED STATES GOVERNMENT, MINI-CIRCUITS RESERVES ALL PROPRIETARY DESIGN, USE, MANUFACTURING AND REPRODUCTION RIGHTS THERETO. THESE CONTENTS SHALL NOT BE USED, DUPLICATED OR DISCLOSED TO ANY OUTSIDE PARTY, IN WHOLE OR IN PART, WITHOUT WRITTEN PERMISSION OF MINI-CIRCUITS.
ASHEETA1.DWG REV:A DATE:01/12/95



Mini-Circuits®

13 Neptune Avenue
Brooklyn NY 11235

PL, 12AM05, DQ1225, TB-TSS-13LN+/13HLN+

SIZE	CODE IDENT	DRAWING NO:	REV:
A	15542	98-PL-623	OR
FILE:	98PL623	SCALE: 8:1	SHEET: 1 OF 1

Evaluation Board and Circuit

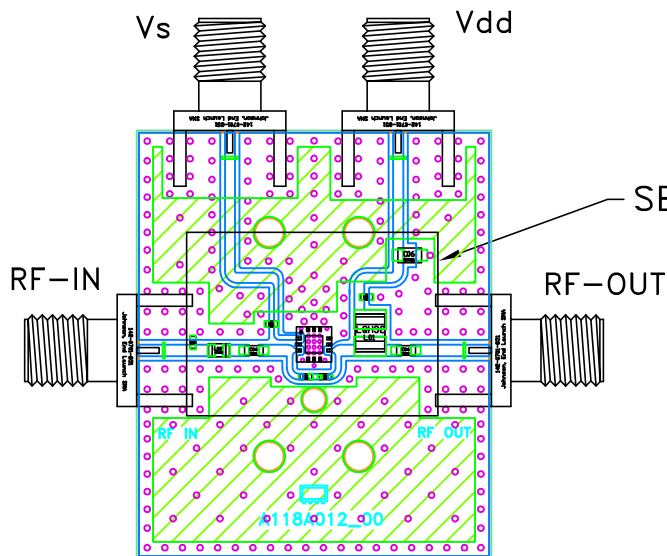

SEE DETAIL "B"

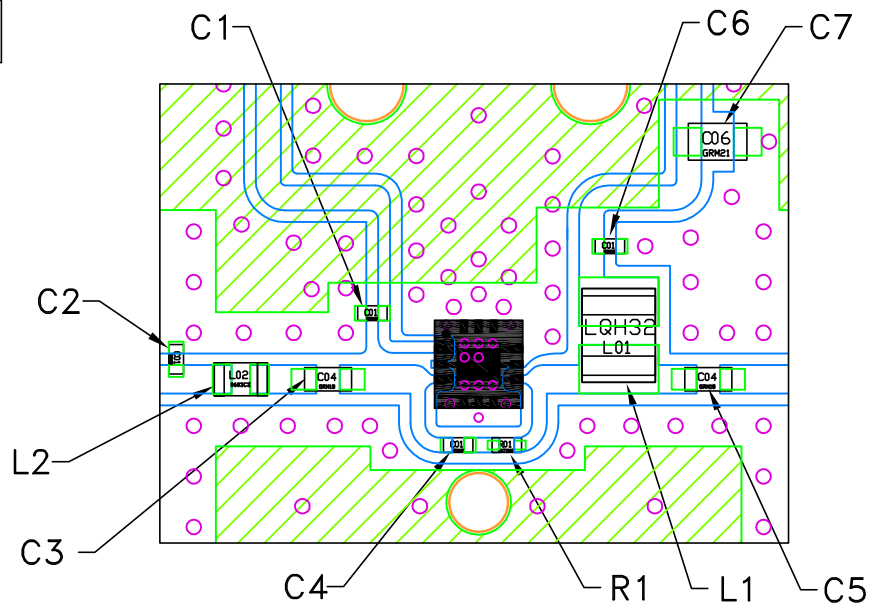

DETAIL "B"

LOCATION OF CHIP COMPONENTS ON THE PCB

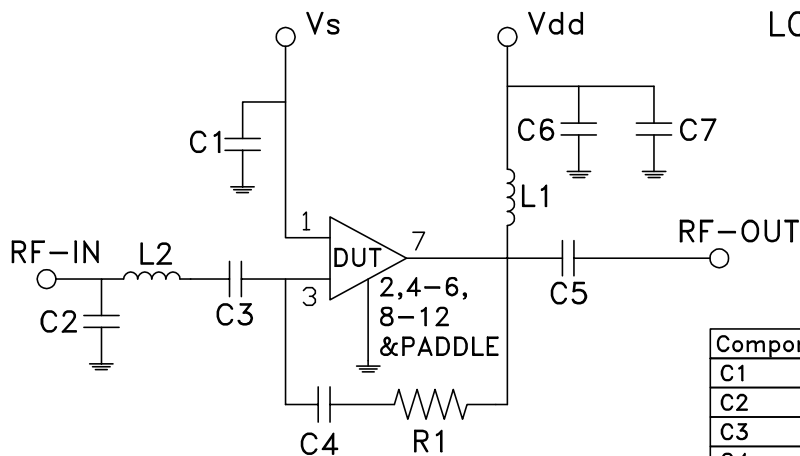

Component	Size	Value	Part Number	Manufacturer
C1	0402	0.1uF	GRM155R71C104KA88D	Murata
C2	0402	1.5pF	GRM1555C1H1R5CA1D	Murata
C3	0603	2.2uF	GRM188C71E225KE11D	Murata
C4	0402	0.1uF	GRM155R71C104KA88D	Murata
C5	0603	2.2uF	GRM188C71E225KE11D	Murata
C6	0402	1000pF	GRM1555C1H102JA01D	Murata
C7	0805	10uF	GRM21BC71E106KE11L	Murata
L1	1210	15uH	LQH32DN150K53L	Murata
L2	0603	5.1nH	0603CS-5N1XJLU	Coilcraft
R1	0402	1.5K0hm	RK73H1ETTP1501F	Koa

Schematic Diagram

NOTES:

1. 50 Ohm SMA Female Connectors.
2. PCB Material: Roger RO4350B or equivalent, Dielectric constant=3.5, Thickness=0.02 inch

 **Mini-Circuits®**



All Mini-Circuits products are manufactured under exacting quality assurance and control standards, and are capable of meeting published specifications after being subjected to any or all of the following physical and environmental test.

Specification	Test/Inspection Condition	Reference/Spec
Operating Temperature	-40° to 95° C / 105° C Ambient Environment	Individual Model Data Sheet
Storage Temperature	-55° to 100° C or -65° to 150° Ambient Environment	Individual Model Data Sheet
Thermal Shock	-55° to 100°C, 100 cycles	MIL-STD-202, Method 107, Condition A-3, except +100°C
Mechanical Shock	1.5Kg, 0.5 ms, 5 shock pulses, Y1 direction only	MIL-STD-883, Method 2002, Condition B, except Y1 direction only
Vibration (Variable Frequency)	50g peak	MIL-STD-883, Method 2007, Condition B
Autoclave	15 psig, 100% RH, 121°C, 96 hours	JESD22-A102-C, Condition C
HAST	130°C, 85% RH, 96 hours	JESD22-A110
Solderability	10X Magnification	J-STD-002, Para 4.2.5, Test S, 95% Coverage
Solder Reflow Heat	Sn-Pb Eutetic Process: 240°C peak Pb-Free Process: 260°C peak	J-STD-020C, Table 4-1, 4-2 and 5-2; Figure 5-1
Moisture Sensitivity: Level 1	Bake at 125°C for 24 hours. Soak at 85°C/85%RH for 168 hours Reflow 3 cycles at 260°C peak	J-STD-020
Marking Resistance to Solvents	Isopropyl alcohol + mineral spirits at 25°C; terpene defluxer at 25°C; distilled water + proylene glycol monomethyl ether +	MIL-STD-202, Method 215



All Mini-Circuits products are manufactured under exacting quality assurance and control standards, and are capable of meeting published specifications after being subjected to any or all of the following physical and environmental test.

Specification	Test/Inspection Condition	Reference/Spec
	monoethanolamine at 63°C to 70°C	