

# Surface Mount Sequencing & DC Control Module

# NON-CATALOG

## VCM-1+

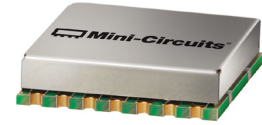

CASE STYLE: BG1482-1  
PRICE: Contact Sales Dept.

### +RoHS Compliant

The +Suffix identifies RoHS Compliance. See our web site for RoHS Compliance methodologies and qualifications

### Maximum Ratings

Operating Temperature	-40°C to 85°C
Operating Temperature	-40°C to 85°C
Positive Input Voltage	+7.4V
Negative Input Voltage	-6.0V
Total DC	620 mA
Permanent damage may occur if any of these limits are exceeded.	

### Pad Description

NEGATIVE OUTPUT	2
POSITIVE OUTPUT	6
POSITIVE INPUT	9
NEGATIVE INPUT	13
GND	1,3,4,5,7,8,10,11,12,14

### Outline Drawing

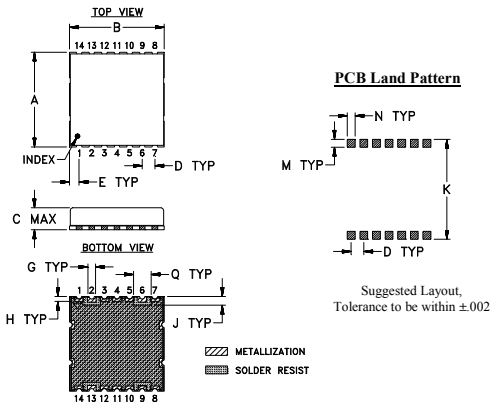

### Outline Dimensions (inch/mm)

A	B	C	D	E	F	G	H
.750	.750	.220	.100	.075	--	.060	.040
19.05	19.05	5.59	2.54	1.91	--	1.52	1.02
J	K	L	M	N	P	Q	wt
.070	.791	--	.063	.061	--	.140	grams
1.78	20.09	--	1.60	1.55	--	3.56	2.05

### Features

- Provides correct voltage sequence and DC control for the PHEMT amplifier [AVM-273HP+](#)
- Replaces over 20 discrete components
- Protection from reverse polarity

### Applications

- [AVM-273HP+](#) PHEMT Amplifier

### Electrical Specifications at 25°C

Parameter	Min.	Typ.	Max.	Units
Positive Input Voltage	+5.9	+6.1	+6.3	V
Negative Input Voltage	-5.5	-5.0	-4.5	V
Positive Output Voltage	--	+5.0	--	V
Negative Output Voltage	--	-0.8	--	V
Controlled DC from positive line	--	560	--	mA
Sinking DC to the negative line	--	-0.5	--	mA

### Schematic

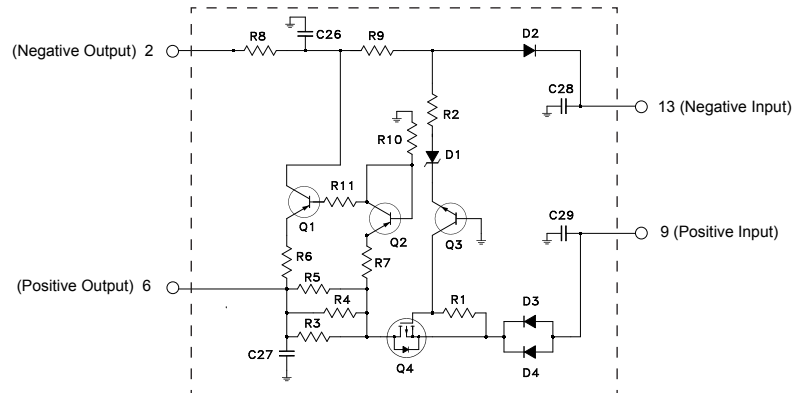

### BOM

SEQ	Manufacturer P/N	Description	Manufacturer
Q1,Q2	MMBT3906	PNP Transistor	Fairchild Semiconductor
Q3	MMBT3904	NPN Transistor	Fairchild Semiconductor
Q4	NTS4101PT1G	P-Channel MOSFET	ON Semiconductor
D1	MMSZ5228BT1G	Zener Diode	ON Semiconductor
D2-D4	MBR0520LT1G	Schottky Diode	ON Semiconductor
C26,C27	GRM1555C1H101GA01D	0402 Capacitor, 100 pF, 2%	Murata Electronics
C28,C29	GRM188R71C105KA12D	0603 Capacitor, 1µF	Murata Electronics
R1,R2,R9,R10	RK73H1JTDD1002F	0603 Resistor, 10kΩ	KOA Speer
R3-R5	RK73H2BTDD3R32F	1206 Resistor, 3.32 Ω	KOA Speer
R6	RK73H1JTDD1000F	0603 Resistor, 100 Ω	KOA Speer
R7	RK73H1JTDD1501F	0603 Resistor, 1.5 kΩ	KOA Speer
R8	RK73H1JTDD1001F	0603 Resistor, 1.0 kΩ	KOA Speer
R11	RK73Z2BTDD	1206 Resistor, 0 Ω	KOA Speer

### Notes

- A. Performance and quality attributes and conditions not expressly stated in this specification document are intended to be excluded and do not form a part of this specification document.  
 B. Electrical specifications and performance data contained in this specification document are based on Mini-Circuit's applicable established test performance criteria and measurement instructions.  
 C. The parts covered by this specification document are subject to Mini-Circuits standard limited warranty and terms and conditions (collectively, "Standard Terms"); Purchasers of this part are entitled to the rights and benefits contained therein. For a full statement of the Standard Terms and the exclusive rights and remedies thereunder, please visit Mini-Circuits' website at [www.minicircuits.com/WCLStore/terms.jsp](http://www.minicircuits.com/WCLStore/terms.jsp)



## Outline Dimensions

BG1482-1

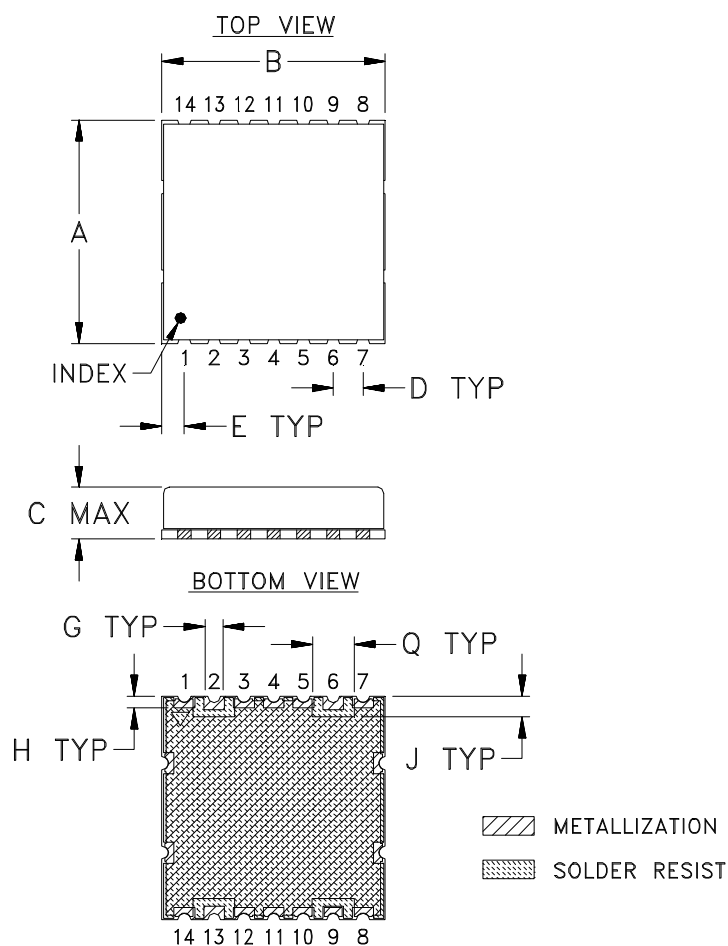

## PCB Land Pattern

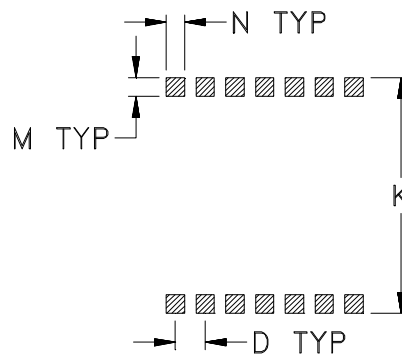

Suggested Layout,  
Tolerance to be within  $\pm .002$

CASE #	A	B	C	D	E	F	G	H	J	K	L	M	N	P	Q	WT, GRAM
BG1482-1	.750 (19.05)	.750 (19.05)	.220 (5.59)	.100 (2.54)	.075 (1.91)	-	.060 (1.52)	.040 (1.02)	.070 (1.78)	.791 (20.09)	-	.063 (1.60)	.061 (1.55)	-	.140 (3.56)	2.05

Dimensions are in inches (mm). Tolerances: 2PL. +/- .03; 3PL. +/- .015

### Notes:

1. Case material: Nickel-Silver alloy.
2. Base: Printed wiring laminate.
3. Termination finish:

For RoHS Case Styles: 2-5  $\mu$  inch (.05-.13 microns) Gold over 120-240  $\mu$  inch (3.05-6.10 microns) Nickel plate. All models (+) suffix.



INTERNET <http://www.minicircuits.com>

P.O. Box 350166, Brooklyn, New York 11235-0003 (718) 934-4500 Fax (718) 332-4661

Distribution Centers NORTH AMERICA 800-654-7949 • 417-335-5935 • Fax 417-335-5945 • EUROPE 44-1252-832600 • Fax 44-1252-837010

Mini-Circuits ISO 9001 & ISO 14001 Certified

# Tape & Reel Packaging TR-F21

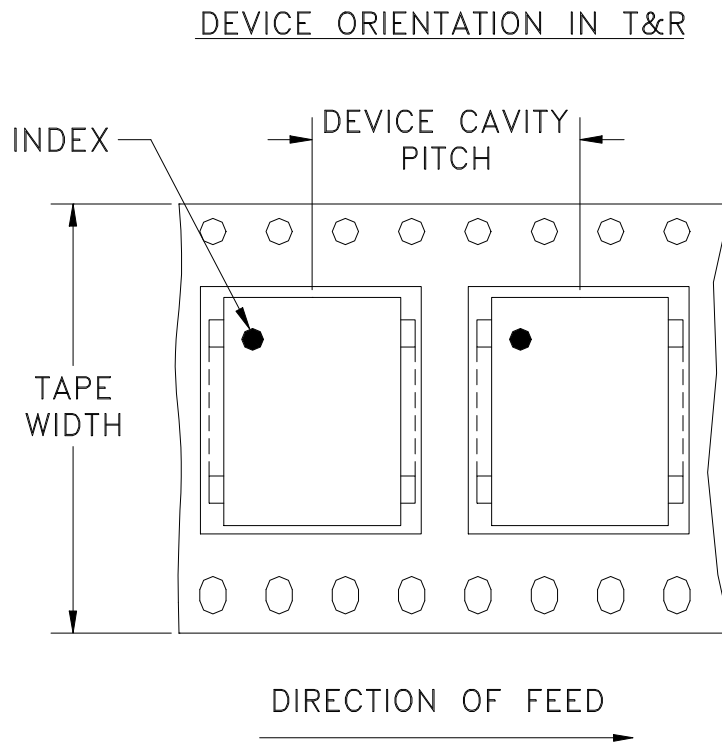

<b>Tape Width, mm</b>	<b>Device Cavity Pitch, mm</b>	<b>Reel Size, inches</b>	<b>Devices per Reel</b>
32	32	13	200

Mini-Circuits carrier tape materials provide protection from ESD (Electro-Static Discharge) during handling and transportation. Tapes are static dissipative and comply with industry standards EIA-481/EIA-541.

Go to: [www.minicircuits.com/pages/pdfs/tape.pdf](http://www.minicircuits.com/pages/pdfs/tape.pdf)



INTERNET <http://www.minicircuits.com>

P.O. Box 350166, Brooklyn, New York 11235-0003 (718) 934-4500 Fax (718) 332-4661

Distribution Centers NORTH AMERICA 800-654-7949 • 417-335-5935 • Fax 417-335-5945 • EUROPE 44-1252-832600 • Fax 44-1252-837010

Mini-Circuits ISO 9001 & ISO 14001 Certified

All Mini-Circuits products are manufactured under exacting quality assurance and control standards, and are capable of meeting published specifications after being subjected to any or all of the following physical and environmental test.

Specification	Test/Inspection Condition	Reference/Spec
Operating Temperature	-40° to 85°C Ambient Environment	Individual Model Data Sheet
Storage Temperature	-55° to 100° C Ambient Environment	Individual Model Data Sheet
Humidity	90 to 95% RH, 240 hours, 50°C	MIL-STD-202, Method 103, Condition A, Except 50°C and end-point electrical test done within 12 hours
Thermal Shock	-55° to 100°C, 100 cycles	MIL-STD-202, Method 107, Condition A-3, except +100°C
Solder Reflow Heat	Sn-Pb Eutetic Process: 225°C peak Pb-Free Process 245° - 250°C peak	J-STD-020, Table 4-1, 4-2 and 5-2, Figure 5-1
Solderability	10X Magnification	J-STD-002, 95% Coverage
Vibration (High Frequency)	20g peak, 10-2000 Hz, 12 times in each of three perpendicular directions (total 36)	MIL-STD-202, Method 204, Condition D
Mechanical Shock	50g, 11 ms, 1/2-sine, 18 shocks: 3 each direction, each of 3 axes	MIL-STD-202, Method 213, Condition A
Marking Resistance to Solvents	Isopropyl alcohol + mineral spirits at 25°C; terpene defluxer at 25°C; distilled water + proylene glycol monomethyl ether + monoethanolamine at 63°C to 70°C	MIL-STD-202, Method 215