

Low Pass Filter

VLF-180+ VLF-180

50Ω DC to 180 MHz



CASE STYLE: FF704

Connectors	Model
SMA	VLF-180+
SMA	VLF-180

Maximum Ratings

Operating Temperature -55°C to 100°C

Storage Temperature -55°C to 100°C

RF Power Input* 8W at 25°C

DC Current Input to Output 0.5A max. at 25°C

*Passband rating, derate linearly to 3 W at 100°C ambient
Permanent damage may occur if any of these limits are exceeded.

Features

- Rugged uni-body construction, small size
- 7 sections
- Excellent power handling, 8W
- Temperature stable
- Low cost
- Protected by US patent 6,943,646

Applications

- Harmonic rejection
- Transmitters/receivers
- Lab use

+RoHS Compliant

The +Suffix identifies RoHS Compliance. See our web site for RoHS Compliance methodologies and qualifications

Outline Drawing

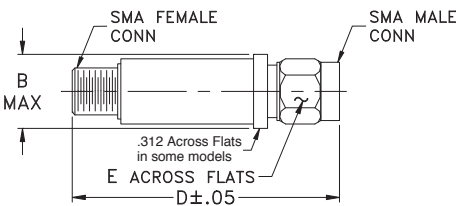

Low Pass Filter Electrical Specifications (T_{AMB} = 25°C)

PASSBAND (MHz) (loss < 1 dB) Max.	f _{co} , MHz Nom. (loss 3 dB) Typ.	STOP BAND (MHz) (loss, dB)			VSWR (:1)		NO. OF SECTIONS
		F 20 Min.	40 Typ.	FR 20 Typ.	Stopband Typ.	Passband Typ.	
DC - 180	270	370	525 - 2350	6400	17	1.2	7

Typical frequency response

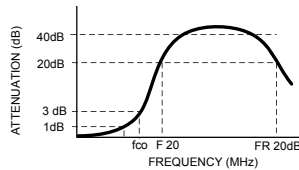

Electrical schematic

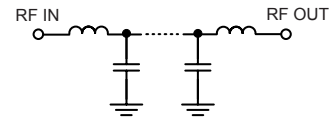

Outline Dimensions (inch/mm)

B	D	E	wt.
.410	1.43	.312	grams
10.41	36.32	7.92	10

Typical Performance Data at 25°C

Frequency (MHz)	Insertion Loss (dB)	VSWR (:1)
40	0.26	1.08
100	0.46	1.08
180	0.84	1.14
235	1.55	1.39
270	3.14	1.81
300	7.42	2.86
325	14.85	4.43
350	25.50	5.77
370	35.45	6.32
525	40.87	11.69
950	66.29	52.65
1700	52.11	62.05
2350	37.00	66.82
4500	23.37	31.03
6400	18.35	28.03
8500	43.67	9.53
12000	19.07	4.69

VLF-180
INSERTION LOSS

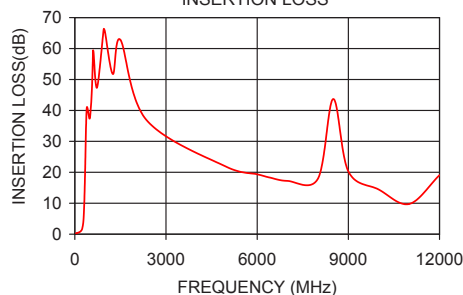

VLF-180
VSWR

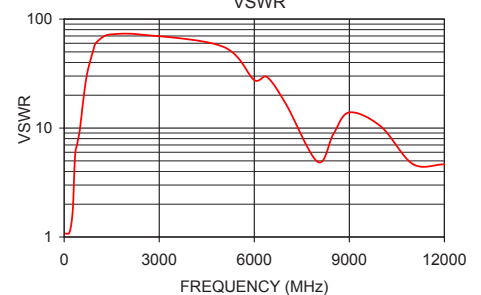

Notes

- Performance and quality attributes and conditions not expressly stated in this specification document are intended to be excluded and do not form a part of this specification document.
- Electrical specifications and performance data contained in this specification document are based on Mini-Circuit's applicable established test performance criteria and measurement instructions.
- The parts covered by this specification document are subject to Mini-Circuits standard limited warranty and terms and conditions (collectively, "Standard Terms"); Purchasers of this part are entitled to the rights and benefits contained therein. For a full statement of the Standard Terms and the exclusive rights and remedies thereunder, please visit Mini-Circuits' website at www.minicircuits.com/MCLStore/terms.jsp



Coaxial Low Pass Filter

VLF-180

Typical Performance Data

FREQ. (MHz)	INSERTION LOSS (dB)			INPUT RETURN LOSS (dB)			OUTPUT RETURNLOSS (dB)		
	@ -55° C	@ +25° C	@ +100° C	@ -55° C	@ +25° C	@ +100° C	@ -55° C	@ +25° C	@ +100° C
40	0.25	0.29	0.33	31.41	30.21	28.56	32.28	30.91	29.19
50	0.24	0.29	0.33	30.39	29.48	28.04	31.37	30.43	28.88
60	0.27	0.32	0.36	29.56	28.94	27.64	30.78	30.13	28.73
80	0.33	0.38	0.42	28.43	27.94	26.93	30.33	29.79	28.75
100	0.39	0.45	0.49	27.72	27.14	26.33	30.68	29.87	28.98
120	0.45	0.52	0.57	27.27	26.54	25.88	32.15	30.59	29.70
140	0.52	0.60	0.66	26.61	25.94	25.56	33.02	31.10	30.52
150	0.57	0.65	0.71	26.04	25.54	25.40	31.87	30.56	30.52
160	0.61	0.70	0.76	25.32	25.01	25.19	29.93	29.34	29.94
170	0.66	0.76	0.82	24.42	24.32	24.81	27.71	27.58	28.59
180	0.72	0.82	0.89	23.32	23.35	24.09	25.56	25.62	26.70
200	0.87	0.98	1.07	20.60	20.65	21.35	21.74	21.79	22.46
235	1.36	1.51	1.62	14.33	14.38	14.48	16.05	16.15	16.23
250	1.80	1.94	2.07	11.38	11.55	11.61	13.67	14.04	14.14
270	2.88	2.99	3.12	7.59	7.95	8.09	10.38	11.20	11.65
290	5.17	5.14	5.20	4.41	4.83	5.07	7.20	8.17	8.96
310	9.49	9.21	9.12	2.38	2.71	2.94	4.78	5.51	6.21
325	14.25	13.75	13.54	1.61	1.87	2.05	3.67	4.19	4.69
340	20.12	19.40	19.07	1.26	1.47	1.61	3.03	3.42	3.77
350	24.49	23.64	23.25	1.14	1.33	1.46	2.77	3.12	3.41
370	33.44	32.63	32.24	1.01	1.18	1.30	2.46	2.80	3.06
500	38.67	38.54	38.42	0.73	0.87	0.99	1.52	1.75	1.99
525	41.26	40.94	40.67	0.69	0.82	0.93	1.31	1.52	1.71
560	47.12	46.19	45.76	0.66	0.77	0.88	1.08	1.24	1.39
580	52.43	51.00	50.07	0.61	0.72	0.83	0.95	1.11	1.23
610	59.33	59.99	58.74	0.58	0.69	0.79	0.81	0.94	1.05
660	49.89	50.58	51.04	0.52	0.61	0.70	0.63	0.73	0.82
900	57.86	56.00	54.99	0.29	0.37	0.43	0.32	0.35	0.41
950	69.27	64.10	61.36	0.30	0.36	0.42	0.30	0.33	0.38
1500	66.72	67.20	67.69	0.17	0.20	0.24	0.29	0.29	0.33
2350	35.22	36.22	36.48	0.42	0.38	0.37	0.23	0.26	0.32
3150	26.48	26.44	26.89	0.27	0.36	0.45	1.42	1.22	1.26
5000	21.44	21.64	21.83	0.65	0.83	1.05	0.22	0.33	0.48
6400	17.70	17.92	18.21	0.19	0.35	0.53	0.56	0.57	0.63
7000	16.96	16.93	17.08	0.28	0.49	0.73	1.29	1.23	1.23
8500	29.50	36.55	36.37	1.88	2.09	1.82	1.78	1.85	2.12
10000	19.38	17.49	15.29	2.00	2.45	2.48	1.44	1.71	1.94
11000	12.07	10.88	11.09	5.23	4.99	4.14	4.02	4.23	4.20
13000	20.57	18.45	17.28	3.06	3.82	5.19	3.46	4.02	4.51
15000	12.39	11.60	11.59	0.90	1.30	1.55	4.68	3.67	3.70
16000	15.61	18.77	25.45	1.24	1.42	1.81	9.51	11.32	13.23
18000	20.48	16.69	10.14	0.86	1.67	2.54	2.82	4.90	7.30

REV. X1
VLF-180
071008
Page 1 of 1



IF/RF MICROWAVE COMPONENTS • ISO 9001 ISO 14001 AS 9100 CERTIFIED • RoHS compliant
P.O. Box 350166, Brooklyn, New York 11235-0003 (718) 934-4500 Fax (718) 332-4661



The Design Engineers Search Engine finds the model you need, Instantly • For detailed performance specs & shopping online see



Typical Performance Curves

INSERTION LOSS vs. TEMPERATURE

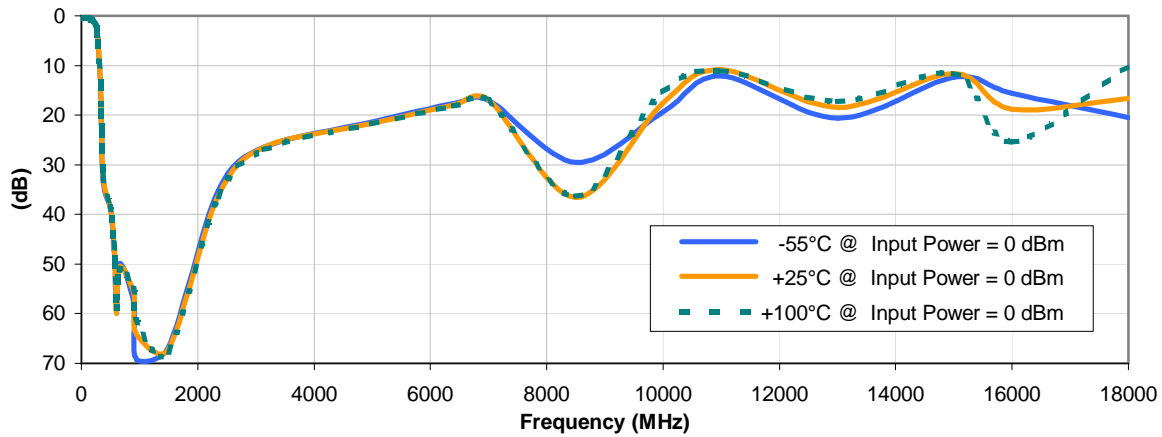

INPUT RETURN LOSS vs. TEMPERATURE

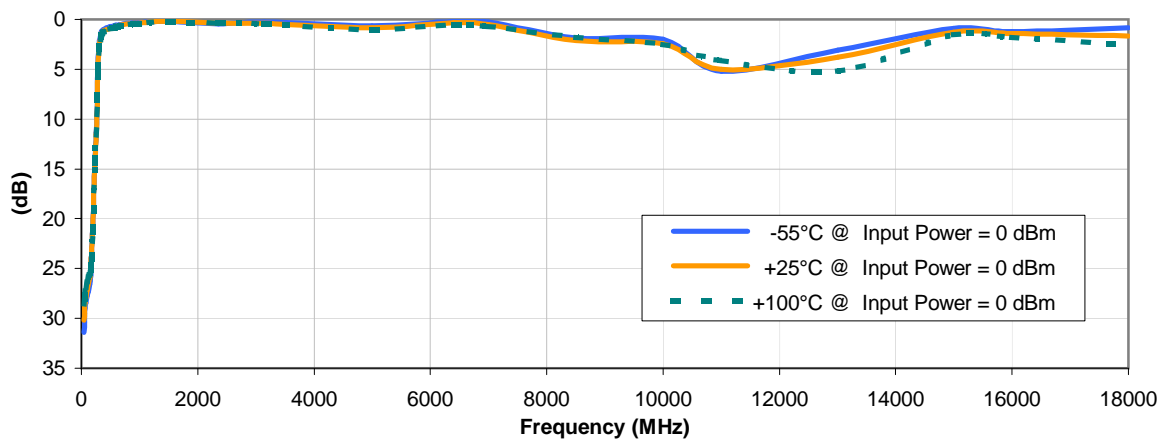

OUTPUT RETURN LOSS vs. TEMPERATURE

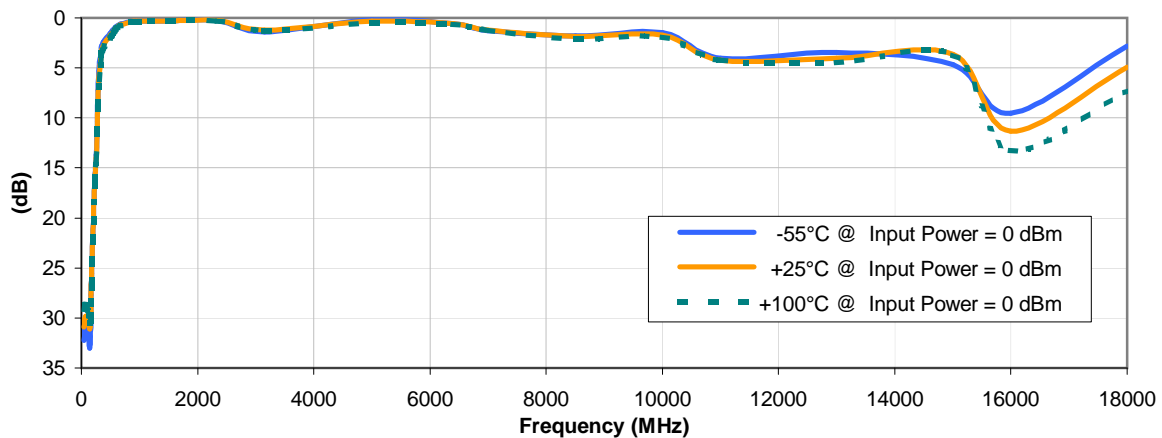

Case Style

FF

FF704

Outline Dimensions

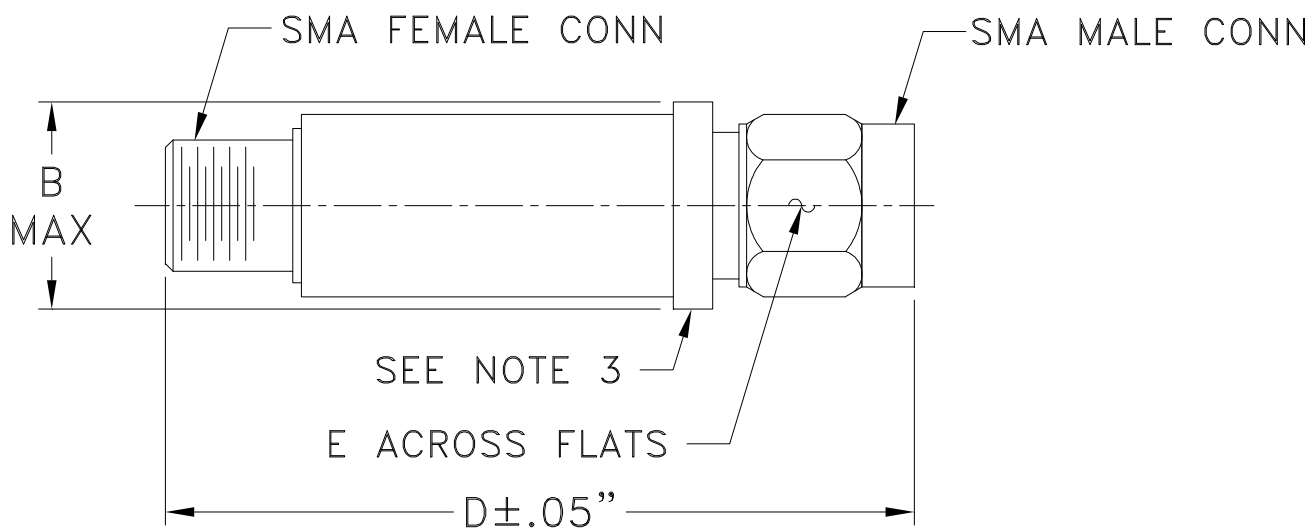

CASE #.	A	B	C	D	E	WT GRAMS
FF704	--	.410 (10.41)	--	1.43 (36.32)	.312 (7.92)	10.0

Dimensions are in inches (mm). Tolerances: 2Pl. ± .04; 3Pl. ± .030

Notes:

1. Case material: Stainless steel.
2. Case finish: Gold plated.
3. Round Flange may have .312 Across Flats in some models.

Mini-Circuits®
ISO 9001 ISO 14001 CERTIFIED

ALL NEW
minicircuits.com

P.O. Box 350166, Brooklyn, New York 11235-0003 (718) 934-4500 Fax (718) 332-4661 For detailed performance specs & shopping online see Mini-Circuits web site



The Design Engineers Search Engine Provides ACTUAL Data Instantly From MINI-CIRCUITS At: www.minicircuits.com

RF/IF MICROWAVE COMPONENTS



All Mini-Circuits products are manufactured under exacting quality assurance and control standards, and are capable of meeting published specifications after being subjected to any or all of the following physical and environmental test.

Specification	Test/Inspection Condition	Reference/Spec
Operating Temperature	-55° to 100°C Ambient Environment	Individual Model Data Sheet
Storage Temperature	-55° to 100° C Ambient Environment	Individual Model Data Sheet
Barometric Pressure	100,000 Feet	MIL-STD-202, Method 105, Condition D
Humidity	90% RH, 65°C Units may require bake-out after humidity to restore full performance.	MIL-STD-202, Method 103
Thermal Shock	-65° to 125°C, 5 cycles	MIL-STD-202, Method 107, Condition B
Vibration (High Frequency)	20g peak, 10-2000 Hz, 12 times in each of three perpendicular directions (total 36)	MIL-STD-202, Method 204, Condition D
Mechanical Shock	100g, 6ms sawtooth, 3 shocks each direction 3 axes (total 18)	MIL-STD-202, Method 213, Condition I