

Coaxial Low Pass Filter

VLFG-2750+

50Ω DC to 2750 MHz



Generic photo used for illustration purposes only
CASE STYLE: FF704

The Big Deal

- Excellent power handling, 4.5W
- Temperature stable
- Rugged unibody construction
- Good rejection, 42 dB typical

Product Overview

VLFG-2750+ is a 50Ω low pass filter built in rugged unibody construction. Covering DC-2750 MHz bandwidth, these units offer good matching within the passband and good rejection in stopband. VLFG-2750+ offer low insertion loss, and excellent power handling capability. It handles up to 4.5W RF input power and provides a wide operating temperature range from -55°C to 125°C.

Key Features

Feature	Advantages
Low passband insertion loss	Suitable for high performance application.
4.5W Power handling	Supports a range of system power requirements.
Connectorized package	The connectorized package is easy to interface with other devices and well suited for test setups.

Notes

- A. Performance and quality attributes and conditions not expressly stated in this specification document are intended to be excluded and do not form a part of this specification document.
B. Electrical specifications and performance data contained in this specification document are based on Mini-Circuit's applicable established test performance criteria and measurement instructions.
C. The parts covered by this specification document are subject to Mini-Circuits standard limited warranty and terms and conditions (collectively, "Standard Terms"); Purchasers of this part are entitled to the rights and benefits contained therein. For a full statement of the Standard Terms and the exclusive rights and remedies thereunder, please visit Mini-Circuits' website at www.minicircuits.com/MCLStore/terms.jsp



Low Pass Filter

VLFG-2750+

50Ω DC to 2750 MHz



Generic photo used for illustration purposes only
CASE STYLE: FF704

+RoHS Compliant
The +Suffix identifies RoHS Compliance. See our web site for RoHS Compliance methodologies and qualifications

Features

- Low loss, 1.2 dB typical
- Good rejection 42 dB typical
- Excellent power handling, 4.5W
- Temperature stable
- Connectorized package
- Rugged unibody construction

Applications

- Military radar applications
- Test and measurement
- Telecommunication and broadband wireless applications

Electrical Specifications at 25°C

Parameter	F#	Frequency (MHz)	Min.	Typ.	Max.	Unit	
Pass Band	Insertion Loss	DC-F1	DC - 2750	—	1.2	2	dB
	Freq. Cut-Off	F2*	3150	—	3.0	—	dB
	Return Loss	DC-F1	DC - 2750	—	16	—	dB
Stop Band	Rejection Loss	F3-F4	4000 - 4350	20	40	—	dB
		F4-F5	4350 - 7200	33	42	—	dB
		F5-F6	7200 - 10000	—	30	—	dB
		F6-F7	10000 - 16000	—	25	—	dB

In Application where DC voltage is present at either input or output port, DC blocks are required.
* Typically, a ±5% frequency deviation from the stated value may occur on a unit-to-unit basis.

Maximum Ratings

Operating Temperature	-55°C to 125°C
Storage Temperature	-55°C to 125°C
RF Power Input*	4.5W max. @25°C

*Passband rating, derate linearly to 1W at 125°C ambient
Permanent damage may occur if any of these limits are exceeded.

Functional Schematic

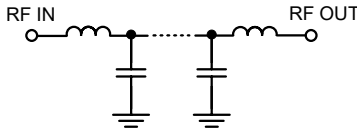

Typical Frequency Response

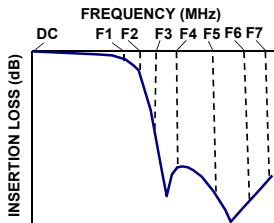

Typical Performance Data at 25°C

Frequency (MHz)	Insertion Loss (dB)	Return Loss (dB)
10	0.05	45.23
100	0.10	36.11
1000	0.36	22.81
1400	0.47	18.54
1800	0.61	16.47
2750	1.06	26.71
3150	2.08	19.35
3220	2.76	13.36
3500	13.38	2.34
3600	20.11	1.59
3730	31.10	1.17
4000	45.70	0.83
4300	55.45	0.69
4350	59.44	0.67
7200	42.68	0.47
8000	40.54	0.45
10000	35.18	0.38
12000	31.77	0.61
15000	28.48	0.88
16000	27.92	0.88

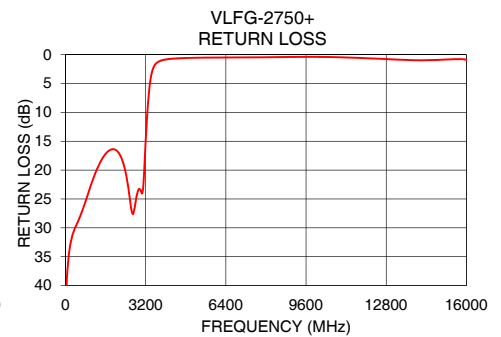
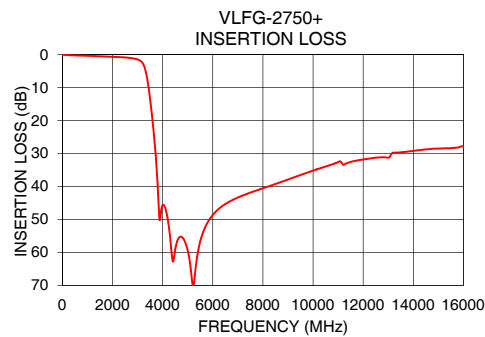
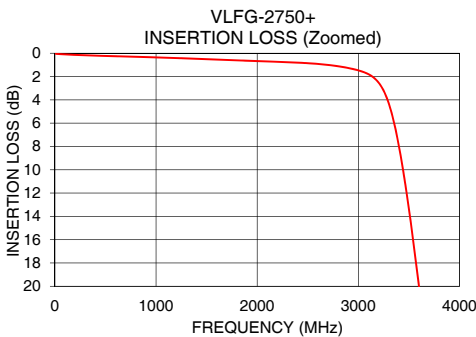

Notes

- Performance and quality attributes and conditions not expressly stated in this specification document are intended to be excluded and do not form a part of this specification document.
- Electrical specifications and performance data contained in this specification document are based on Mini-Circuits' applicable established test performance criteria and measurement instructions.
- The parts covered by this specification document are subject to Mini-Circuits standard limited warranty and terms and conditions (collectively, "Standard Terms"); Purchasers of this part are entitled to the rights and benefits contained therein. For a full statement of the Standard Terms and the exclusive rights and remedies thereunder, please visit Mini-Circuits' website at www.minicircuits.com/MCLStore/terms.jsp



Coaxial Connections

PORT - 1	SMA-Male
PORT - 2	SMA-Female

Outline Drawing

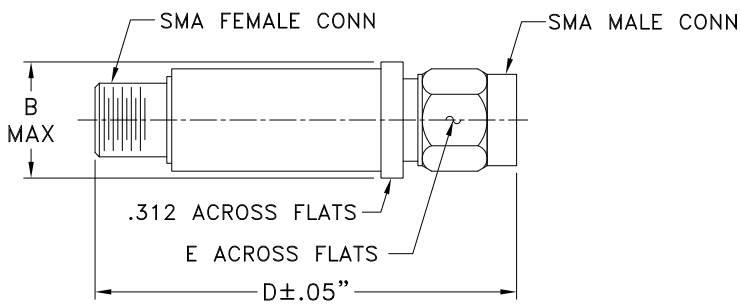

Outline Dimensions (inch / mm)

B	D	E	wt.
.410	1.43	.312	grams
10.41	36.32	7.92	10

Note: Please refer to case style drawing for details

Notes

- A. Performance and quality attributes and conditions not expressly stated in this specification document are intended to be excluded and do not form a part of this specification document.
- B. Electrical specifications and performance data contained in this specification document are based on Mini-Circuit's applicable established test performance criteria and measurement instructions.
- C. The parts covered by this specification document are subject to Mini-Circuits standard limited warranty and terms and conditions (collectively, "Standard Terms"); Purchasers of this part are entitled to the rights and benefits contained therein. For a full statement of the Standard Terms and the exclusive rights and remedies thereunder, please visit Mini-Circuits' website at www.minicircuits.com/MCLStore/terms.jsp



Typical Performance Data

FREQ. (MHz)	INSERTION LOSS			INPUT RETURN LOSS			OUTPUT RETURN LOSS		
	(dB)			(dB)			(dB)		
	@-55°C	@+25°C	@+100°C	@-55°C	@+25°C	@+100°C	@-55°C	@+25°C	@+100°C
10	0.03	0.05	0.06	49.51	45.23	43.38	48.58	44.25	42.28
40	0.05	0.07	0.08	45.09	40.55	37.16	44.66	40.01	36.83
100	0.08	0.10	0.11	38.18	36.11	33.05	37.74	35.24	33.00
160	0.10	0.12	0.13	31.36	33.81	33.39	30.68	32.56	33.05
200	0.12	0.14	0.15	28.82	32.72	34.50	28.15	31.26	33.53
280	0.14	0.17	0.18	27.20	31.24	36.03	26.26	29.23	32.47
300	0.14	0.18	0.19	27.26	30.95	36.08	26.22	28.82	31.97
400	0.16	0.20	0.23	28.92	29.83	34.04	26.79	27.11	29.24
460	0.16	0.22	0.24	29.43	29.26	32.26	26.69	26.29	27.80
520	0.17	0.24	0.26	29.00	28.70	31.05	26.11	25.52	26.67
580	0.18	0.25	0.28	28.05	28.06	30.28	25.34	24.81	25.82
640	0.19	0.27	0.30	27.01	27.37	29.59	24.45	24.12	24.99
700	0.20	0.28	0.32	26.09	26.70	28.66	23.56	23.48	24.13
760	0.21	0.29	0.33	25.34	25.95	27.33	22.88	22.90	23.24
820	0.22	0.31	0.35	24.66	25.17	25.93	22.34	22.32	22.36
880	0.24	0.33	0.37	23.74	24.38	24.64	21.70	21.76	21.55
940	0.25	0.34	0.39	22.55	23.61	23.56	20.83	21.21	20.82
1000	0.27	0.36	0.42	21.40	22.81	22.56	19.99	20.68	20.16
1060	0.28	0.37	0.43	20.69	22.06	21.66	19.48	20.17	19.54
1120	0.29	0.39	0.45	20.41	21.34	20.83	19.31	19.68	18.96
1180	0.30	0.40	0.48	20.23	20.66	20.06	19.23	19.21	18.44
1240	0.31	0.42	0.50	19.86	20.02	19.38	18.98	18.78	17.98
1300	0.32	0.44	0.52	19.29	19.43	18.78	18.56	18.36	17.56
1360	0.34	0.46	0.54	18.72	18.87	18.29	18.14	17.97	17.24
2000	0.52	0.67	0.77	16.45	16.50	17.09	16.62	16.53	17.02
2500	0.66	0.85	0.99	21.30	22.84	23.82	20.94	21.81	22.17
2750	0.81	1.06	1.23	27.90	26.71	27.07	23.33	22.22	22.01
2800	0.86	1.12	1.30	25.85	25.49	25.86	22.17	21.46	21.32
2900	0.99	1.27	1.48	22.46	23.51	24.26	19.92	20.04	20.07
3000	1.16	1.47	1.72	21.39	23.49	24.99	18.57	18.98	18.95
3150	1.63	2.08	2.47	20.86	19.35	18.11	15.77	14.64	13.79
3200	1.95	2.52	3.02	16.85	14.99	13.74	13.32	11.99	11.12
3220	2.13	2.76	3.32	15.10	13.36	12.21	12.21	10.92	10.08
3600	17.97	20.11	21.97	1.40	1.59	1.75	2.04	2.35	2.60
3700	25.66	28.24	30.54	1.00	1.24	1.43	1.84	2.20	2.45
3730	28.31	31.10	33.63	0.93	1.17	1.37	1.80	2.16	2.41
4000	45.66	45.70	45.86	0.60	0.83	1.03	1.52	1.80	1.97
4200	47.85	49.63	51.20	0.52	0.72	0.89	1.24	1.47	1.60
4300	52.83	55.45	57.54	0.49	0.69	0.84	1.11	1.32	1.44
4350	56.44	59.44	61.17	0.48	0.67	0.81	1.04	1.26	1.37
5000	58.43	59.34	60.23	0.38	0.56	0.65	0.50	0.71	0.81
5500	58.01	56.66	55.65	0.29	0.52	0.67	0.33	0.53	0.67
6000	48.85	48.62	48.33	0.23	0.50	0.75	0.23	0.46	0.62
6200	47.01	47.03	46.91	0.21	0.49	0.77	0.22	0.44	0.61
6400	45.57	45.80	45.83	0.21	0.49	0.78	0.21	0.44	0.61
6500	45.02	45.33	45.40	0.21	0.48	0.78	0.20	0.43	0.61
6600	44.51	44.86	44.99	0.20	0.48	0.78	0.20	0.43	0.60
6800	43.72	44.04	44.24	0.20	0.48	0.77	0.19	0.42	0.61
7000	43.06	43.33	43.59	0.21	0.48	0.75	0.19	0.42	0.60
7200	42.48	42.68	42.99	0.21	0.47	0.72	0.19	0.42	0.60
7300	42.20	42.41	42.68	0.21	0.47	0.70	0.20	0.42	0.60
7500	41.73	41.81	42.09	0.21	0.47	0.68	0.20	0.42	0.60
8000	40.45	40.54	40.66	0.19	0.45	0.64	0.21	0.43	0.60
10000	35.37	35.18	35.25	0.11	0.38	0.68	0.22	0.47	0.58
12000	31.82	31.77	31.65	0.15	0.61	0.93	0.22	0.55	0.79
13000	30.68	31.25	31.10	0.30	0.80	1.44	0.30	0.70	1.08
14000	28.69	29.18	30.15	0.39	0.97	1.24	0.19	0.57	0.84
15000	28.93	28.48	28.39	0.23	0.88	1.67	0.10	0.53	0.83
15500	27.99	28.37	28.44	0.49	0.79	1.31	0.08	0.50	0.82
16000	26.87	27.92	29.75	0.80	0.88	1.07	0.06	0.53	0.86

Typical Performance Data

FREQ. (MHz)	GROUP DELAY		
	(nsec)		
	@-55°C	@+25°C	@+100°C
10	0.37	0.36	0.35
80	0.36	0.35	0.34
100	0.36	0.35	0.34
200	0.35	0.34	0.34
260	0.35	0.34	0.34
320	0.35	0.34	0.34
380	0.35	0.34	0.34
440	0.36	0.34	0.34
500	0.36	0.34	0.34
560	0.36	0.35	0.34
620	0.36	0.35	0.34
680	0.36	0.35	0.34
740	0.36	0.35	0.34
800	0.36	0.35	0.34
860	0.36	0.35	0.34
920	0.36	0.35	0.35
980	0.37	0.35	0.35
1000	0.37	0.36	0.35
1100	0.37	0.36	0.35
1160	0.37	0.36	0.35
1200	0.37	0.36	0.35
1280	0.38	0.37	0.36
1300	0.38	0.37	0.36
1400	0.38	0.37	0.36
1460	0.39	0.37	0.37
1500	0.39	0.38	0.37
1580	0.39	0.38	0.37
1600	0.39	0.38	0.38
1700	0.40	0.39	0.38
1760	0.41	0.39	0.39
1800	0.41	0.40	0.39
1880	0.42	0.40	0.40
1900	0.42	0.41	0.40
2000	0.43	0.42	0.41
2100	0.44	0.43	0.43
2200	0.45	0.44	0.44
2300	0.47	0.46	0.46
2400	0.49	0.48	0.48
2500	0.51	0.51	0.50
2700	0.57	0.57	0.57
2750	0.59	0.59	0.59

Typical Performance Curves

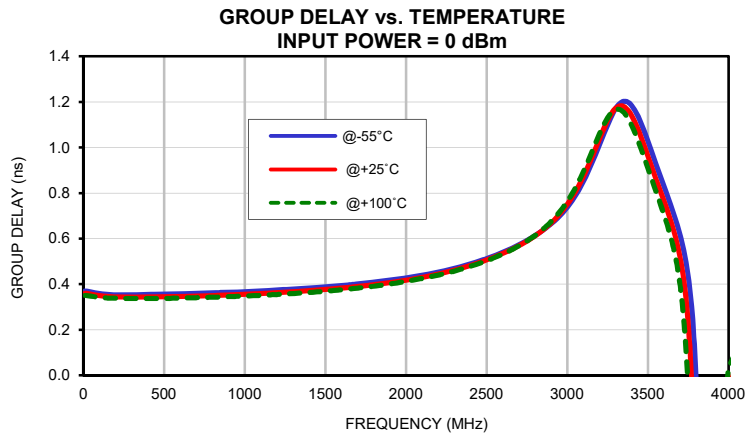
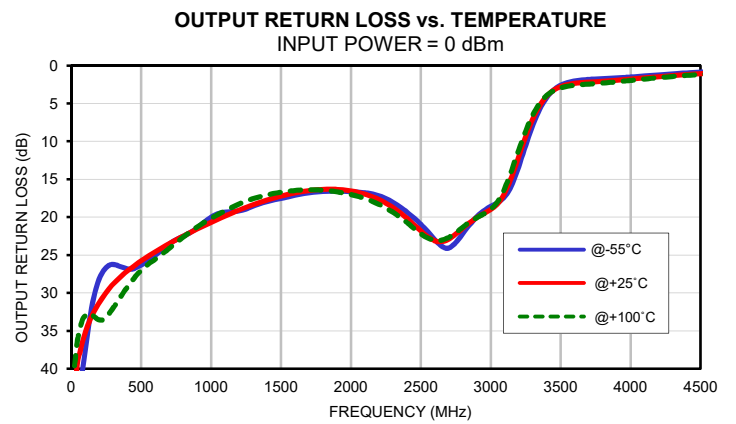
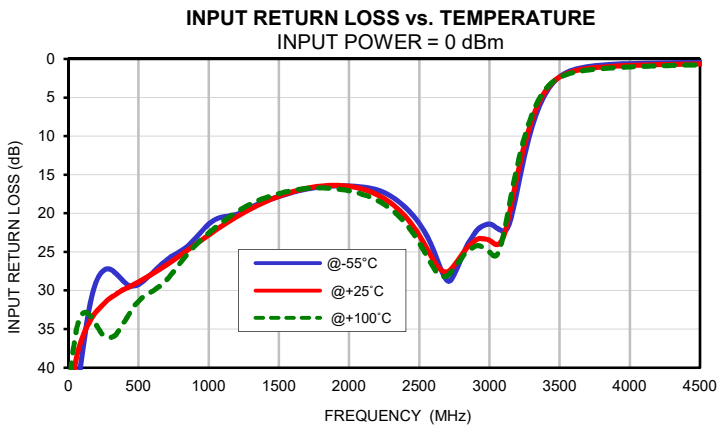
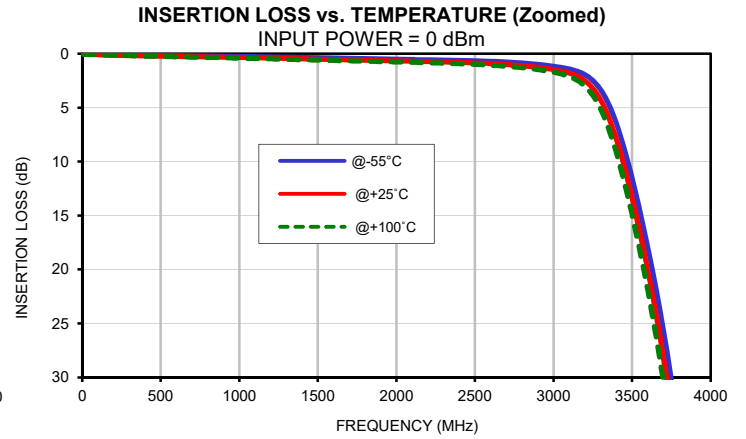
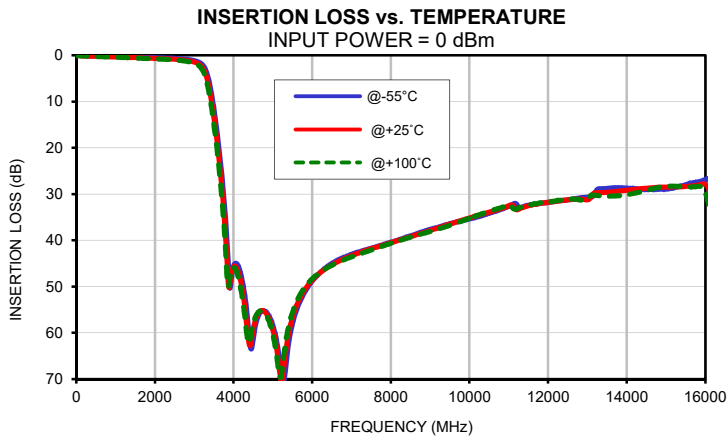

Case Style

FF

FF704

Outline Dimensions

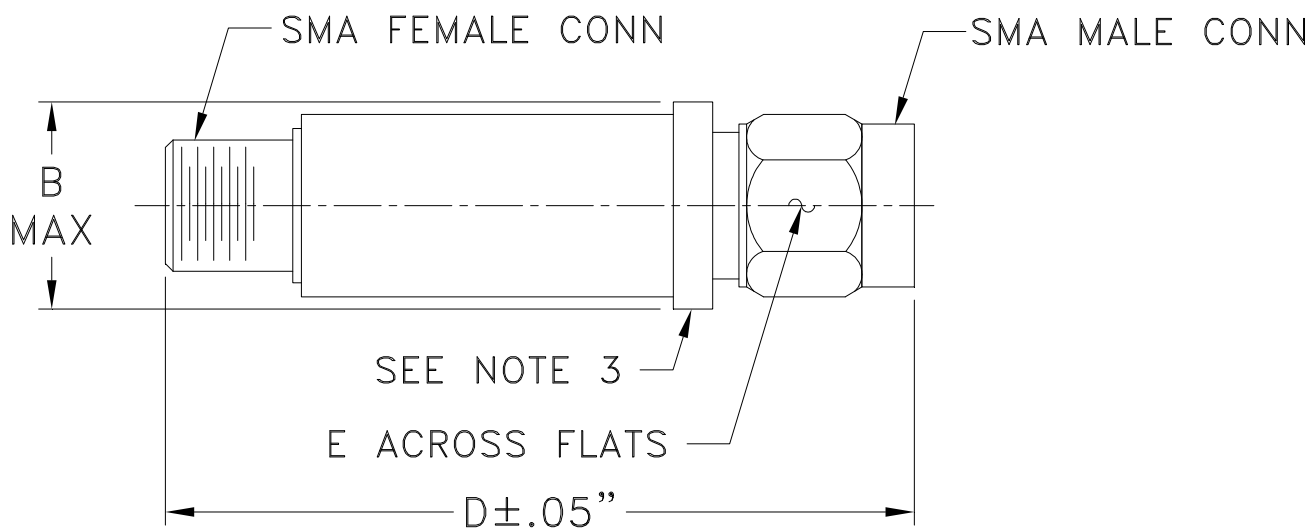

CASE #.	A	B	C	D	E	WT GRAMS
FF704	--	.410 (10.41)	--	1.43 (36.32)	.312 (7.92)	10.0

Dimensions are in inches (mm). Tolerances: 2Pl. ± .04; 3Pl. ± .030

Notes:

1. Case material: Stainless steel.
2. Case finish: Gold plated.
3. Round Flange may have .312 Across Flats in some models.

Mini-Circuits®
ISO 9001 ISO 14001 CERTIFIED

ALL NEW
minicircuits.com

P.O. Box 350166, Brooklyn, New York 11235-0003 (718) 934-4500 Fax (718) 332-4661 For detailed performance specs & shopping online see Mini-Circuits web site



The Design Engineers Search Engine Provides ACTUAL Data Instantly From MINI-CIRCUITS At: www.minicircuits.com

RF/IF MICROWAVE COMPONENTS

All Mini-Circuits products are manufactured under exacting quality assurance and control standards, and are capable of meeting published specifications after being subjected to any or all of the following physical and environmental test.

Specification	Test/Inspection Condition	Reference/Spec
Operating Temperature	-55° to 100° C Ambient Environment	Individual Model Data Sheet
Storage Temperature	-55° to 100° C Ambient Environment	Individual Model Data Sheet
Humidity	90 to 95% RH, 240 hours, 50°C	MIL-STD-202, Method 103, Condition A, Except 50°C and end-point electrical test done within 12 hours
Vibration (High Frequency)	20g peak, 10-2000 Hz, 12 times in each of three perpendicular directions (total 36)	MIL-STD-202, Method 204, Condition D
Mechanical Shock	50g, 11 ms, 1/2-sine, 18 shocks: 3 each direction, each of 3 axes	MIL-STD-202, Method 213, Condition A
Thermal Shock	-55° to 100°C, 5 cycles	MIL-STD-202, Method 107, Condition A, Except +100°C