



Instrumentation Test Cable **VNAX-3FT-EMERF+**

50Ω 3 ft DC to 67 GHz Low Loss 1.85 mm Male to 1.85 mm Rugged Female

THE BIG DEAL

- Ultra-Wideband Operation, DC to 67 GHz
- 1.85 mm Rugged Female Connector for Direct Interface With 67 GHz VNA Ports
- Low Insertion Loss and Excellent Return Loss
- Rugged Construction, Crush and Torque Resistant



Generic photo used for illustration purposes only

Model No.	VNAX-3FT-EMERF+
Case Style	RH2934-3
Connectors	1.85 mm Male to 1.85 mm Rugged Female

APPLICATIONS

- Military and Defense Applications
- Research & Development Labs
- Precision Testing

+RoHS Compliant

The +Suffix identifies RoHS Compliance. See our website for methodologies and qualifications

PRODUCT OVERVIEW

Mini-Circuits' VNAX-3FT-EMERF+ is an ultra-wideband precision rugged instrumentation cable specially designed for use with 67 GHz VNA equipment in test environments. The cable provides excellent VSWR and very low insertion loss over its entire frequency range. 1.85 mm rugged female to 1.85 mm male connector configuration provides direct connection from the ports of a 67 GHz VNA to 1.85 mm connectorized devices without the need for adapters. The cable features a rugged crush and torque resistant outer sheath that protects the cable from damage in demanding lab settings.

KEY FEATURES

Features	Advantages
DC to 67 GHz Operation Designed for Use With Vector Network Analyzers (VNA)	Covers a wide range of test applications; rugged 1.85 mm connector interfaces directly with VNA without the need for an adapter for improved VSWR performance and lower cost.
Rugged Cable-Connector Interface	Chrome-plated metal back shell maintains integrity of the cable-connector interface improving the reliability and extending life of use.
Extra Rugged Yet Flexible Armored Cable Construction	100% coverage, non-interleaved, stainless steel spiral sheath provides crush resistance and captured, opposing force steel braid provides torque resistance. PET monofilament yarn outer cover eliminates conductivity and allows easy handling.
3 ft Length	Standard VNA cable length makes this model a high performing, cost-effective replacement for expensive OEM cables.
Anti-Torque Component	Nut component feature on connector used to fit a torque wrench to minimize stress on connectors and prevent breakage.





Instrumentation Test Cable **VNAX-3FT-EMERF+**

50Ω 3 ft DC to 67 GHz Low Loss 1.85 mm Male to 1.85 mm Rugged Female

ELECTRICAL SPECIFICATIONS AT +25 °C

Parameter	Frequency (GHz)	Min.	Typ.	Max.	Units
Frequency Range		DC		67	GHz
Length		3			ft
Insertion Loss	DC-18	-	1.73	3.2	dB
	18-40	-	3.44	5.1	
	40-50	-	4.51	6.0	
	50-67	-	5.36	6.4	
Return Loss	DC-18	19	33	-	dB
	18-40	17	32	-	
	40-50	16	25	-	
	50-67	16	26	-	

ABSOLUTE MAXIMUM RATINGS

Parameter	Ratings
Operating Temperature	+18 °C to +28 °C
Storage Temperature	-40 °C to +50 °C
Power Handling at +25 °C, Sea Level	115 W at 1 GHz
	59 W at 6 GHz
	27 W at 26.5 GHz
	17 W at 67 GHz

Permanent damage may occur if any of these limits are exceeded.

Product Guarantee

Mini-Circuits® will repair or replace your test cable at its option if the connector attachment fails within six months of shipment. This guarantee excludes cable or connector interface damage from misuse or abuse.





Instrumentation Test Cable **VNAX-3FT-EMERF+**

50Ω 3 ft DC to 67 GHz Low Loss 1.85 mm Male to 1.85 mm Rugged Female

CABLE CONSTRUCTION

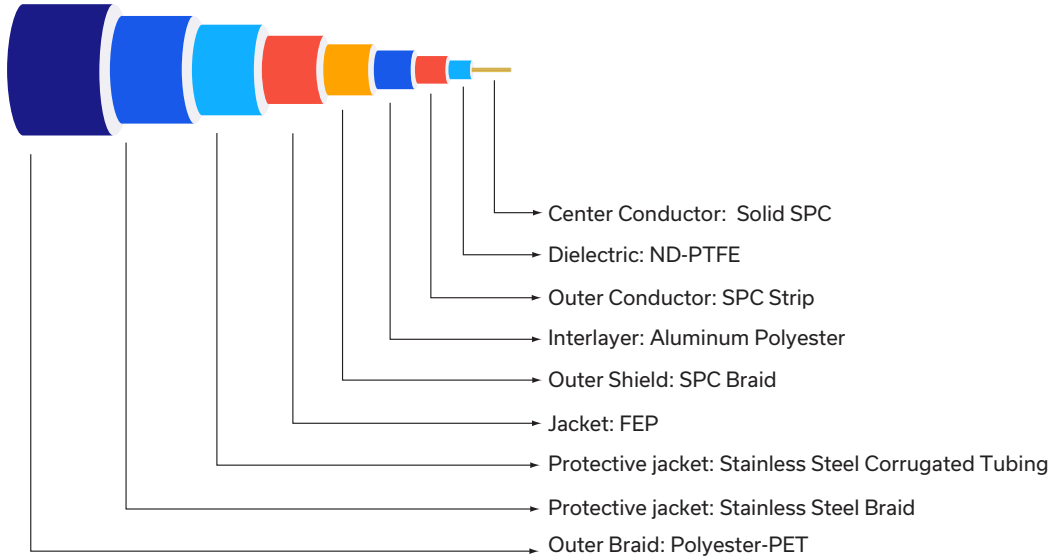

OUTLINE DRAWING

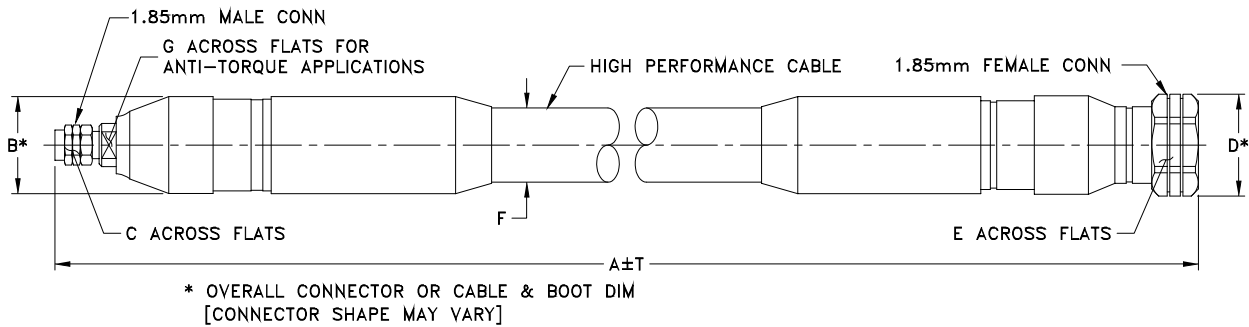

OUTLINE DIMENSIONS (Inch mm)

A	B	C	D	E	F	G	T	wt
Feet	Meters	0.79	.315	0.83	.75	.602	.275	grams
3.00	0.91	20.07	8.00	21.08	19.05	15.3	7.0 +.72/-0 +18.3/-0	506





Instrumentation Test Cable VNAX-3FT-EMERF+

Mini-Circuits

50Ω 3 ft DC to 67 GHz Low Loss 1.85 mm Male to 1.85 mm Rugged Female

TYPICAL PERFORMANCE DATA AND CHARTS

Frequency (MHz)	Insertion Loss (dB)	Return Loss (dB)	
		1.85 mm Male	1.85 mm Female
100	0.17	41.57	40.30
1000	0.58	36.87	37.43
10000	1.91	27.33	28.38
15000	2.38	25.51	25.36
18000	2.62	36.84	31.41
20000	2.79	29.54	27.74
30000	3.51	35.88	36.73
40000	4.18	24.68	29.59
45000	4.52	20.71	22.32
50000	4.85	20.66	20.74
55000	5.12	25.17	23.31
60000	5.42	35.11	28.60
67000	5.87	22.30	23.26

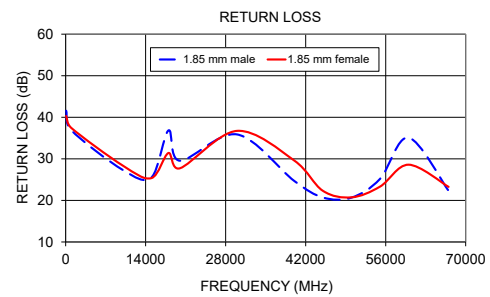
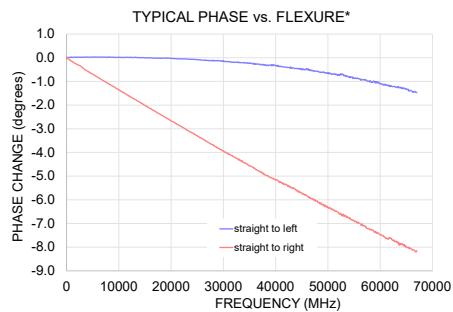

* Typical phase change over flexure performed on VNAX-3FT-KMVRF+ by wrapping cable 360° around 4" radii mandrels referenced to normalized straight position.

** Setup is flipped and measurement is repeated.

NOTES

- Performance and quality attributes and conditions not expressly stated in this specification document are intended to be excluded and do not form a part of this specification document.
- Electrical specifications and performance data contained in this specification document are based on Mini-Circuit's applicable established test performance criteria and measurement instructions.
- The parts covered by this specification document are subject to Mini-Circuits standard limited warranty and terms and conditions (collectively, "Standard Terms"); Purchasers of this part are entitled to the rights and benefits contained therein. For a full statement of the standard terms and the exclusive rights and remedies thereunder, please visit Mini-Circuits' website at www.minicircuits.com/terms/viewterm.html



Flex Test, 1.85mm-Male/1.85mm-Female Ruggedized

Instrumentation Test Cable

VNAX-3FT-EMERF+

Typical Performance Data

FREQUENCY (MHz)	INSERTION LOSS (dB)	1.85mm MALE RETURN LOSS (dB)	1.85mm FEMALE Ruggedized RETURN LOSS (dB)
100	0.17	41.57	40.30
200	0.25	38.54	38.98
300	0.30	38.31	39.39
400	0.36	50.85	44.88
500	0.40	39.99	40.03
600	0.44	38.10	38.91
700	0.48	36.32	39.69
800	0.52	46.51	48.02
900	0.55	41.47	41.12
1000	0.58	36.87	37.43
3000	1.01	28.76	28.66
4000	1.16	44.46	44.63
5000	1.31	37.35	44.70
6000	1.45	35.24	33.59
7000	1.57	32.94	32.81
8000	1.69	28.67	28.05
9000	1.80	42.03	33.39
10000	1.91	27.33	28.38
11000	2.00	32.62	39.61
12000	2.11	27.66	26.75
13000	2.19	33.35	32.66
14000	2.28	30.15	33.61
15000	2.38	25.51	25.36
16000	2.46	39.21	32.30
17000	2.54	32.80	30.51
18000	2.62	36.84	31.41
19000	2.71	32.02	30.00
20000	2.79	29.54	27.74
21000	2.86	38.13	29.57
22000	2.94	28.13	26.57
23000	3.01	34.49	37.63
24000	3.08	34.56	34.59
25000	3.16	36.72	36.30
26000	3.23	31.94	32.02
27000	3.30	30.66	32.43
28000	3.37	46.39	37.54
29000	3.44	32.25	31.31
30000	3.51	35.88	36.73
32000	3.65	29.79	31.03
34000	3.78	29.25	31.39
36000	3.91	27.48	30.57
38000	4.04	28.48	31.95
40000	4.18	24.68	29.59
42000	4.30	26.72	32.38
44000	4.44	24.46	38.21
46000	4.57	23.97	29.15
48000	4.71	20.86	22.44
50000	4.85	20.66	20.74
52000	4.98	20.09	21.05
54000	5.06	24.62	23.57
56000	5.18	29.03	25.08
58000	5.29	34.15	27.76
60000	5.42	35.11	28.60
62000	5.57	32.64	34.26
64000	5.65	34.55	34.06
66000	5.77	24.17	29.56
67000	5.87	22.30	23.26



P.O. Box 350166, Brooklyn, New York 11235-0003 (718) 934-4500 • Fax (718) 332-4661 For detailed performance specs & shopping online see Mini-Circuits web site



The Design Engineers Search Engine Provides ACTUAL Data Instantly From MINI-CIRCUITS At: www.minicircuits.com

IF/RF MICROWAVE COMPONENTS

REV. OR
VNAX-3FT-EMERF+
3/25/2020
Page 1 of 1

Typical Performance Curves

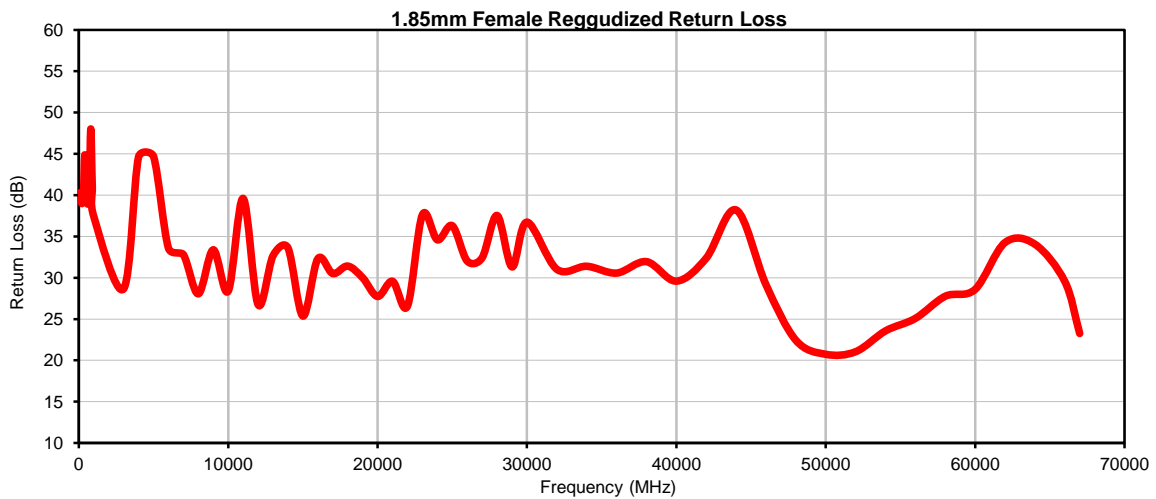
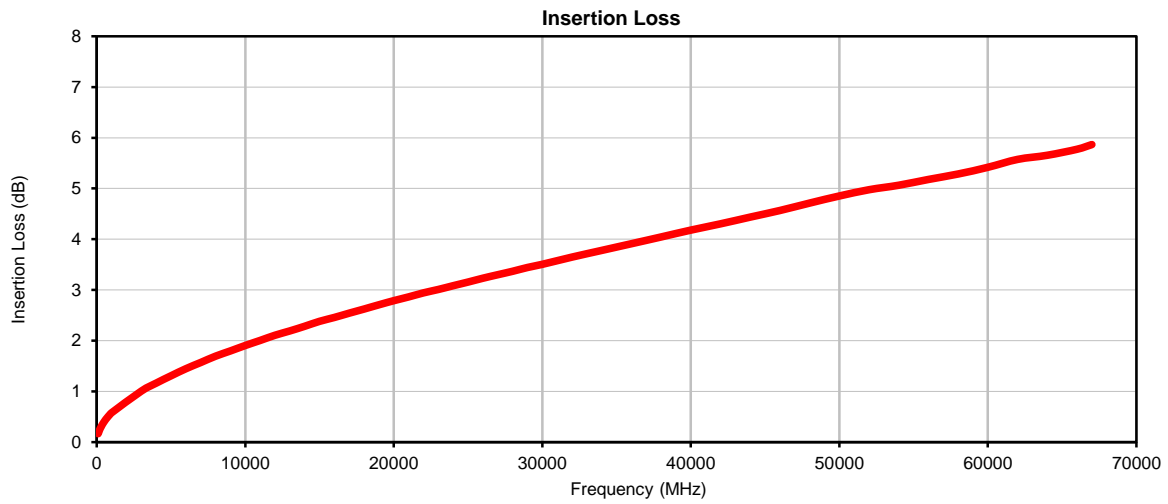

Outline Dimensions

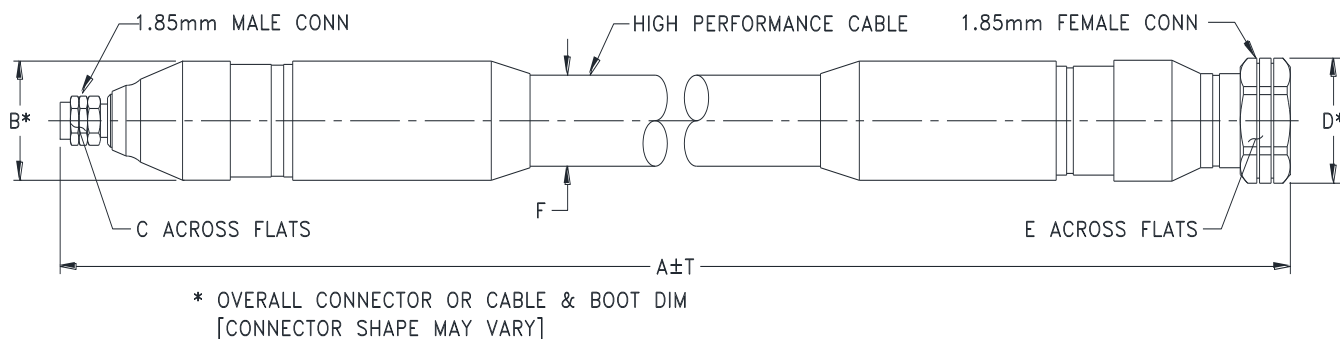

RH2934 SERIES

1.85mm MALE (CONN-1)

1.85mm FEMALE (CONN-2)

CASE STYLE #	A		B	C	D	E	F	T		WEIGHT GRAMS
	FEET	METERS						INCH	MM	
RH2934-2	2.00	.61	.79 (20.0)	.315 (8.00)	.83 (21.00)	.75 (19.00)	.602 (15.3)	+.50/-0	+12.7/-0	414
RH2934-3	3.00	.91						+.72/-0	+18.3/-0	506
RH2934-3.28	3.28	1.00						+.79/-0	+20.0/-0	531

Unless otherwise specified dimensions are in inches (mm).

Tolerances: 2Pl. $\pm .03$; 3Pl. $\pm .015$

Note:

1. High Performance rugged Cable.



P.O. Box 350166, Brooklyn, New York 11235-0003 (718) 934-4500 Fax (718) 332-4661 For detailed performance specs & shopping online see Mini-Circuits web site



The Design Engineers Search Engine Provides ACTUAL Data Instantly From MINI-CIRCUITS At: www.minicircuits.com

RF/IF MICROWAVE COMPONENTS



All Mini-Circuits products are manufactured under exacting quality assurance and control standards, and are capable of meeting published specifications after being subjected to any or all of the following physical and environmental test.

Specification	Test/Inspection Condition	Reference/Spec
Operating Temperature	+18°C to 28°C Ambient Environment	Individual Model Data Sheet
Storage Temperature	-40° to 50°C Ambient Environment	Individual Model Data Sheet