

# Engineering Development Model

## Power Splitter/Combiner WP4-ED12616A/5\_13 4 Way-0°

### Important Note

This model has been designed, built and tested in our engineering department. Performance data represents model capability. At present it is a non-catalog model. On request, we can supply a final specification sheet, part number and price/delivery information.

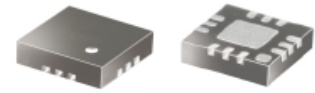

Please click "Back", and then click "Contact Us" for Applications support.

CASE STYLE : DQ1225

ELECTRICAL SPECIFICATIONS 50Ω @ +25°C					
Parameter		Min.	Typ.	Max.	Units
Frequency		3000		4200	MHz
Isolation	3000 - 4200 MHz		26		dB
Insertion Loss Above 6.0 dB	3000 - 4200 MHz		0.70		dB
Phase Unbalance	3000 - 4200 MHz		1.973		deg.
Amplitude Unbalance	3000 - 4200 MHz		0.121		dB
VSWR	SUM Port		1.50		(:1)
	OUT Ports		1.25		(:1)

MAXIMUM RATINGS	
Operating Temperature	-40°C to 85°C
Storage Temperature	-65°C to 150°C

PIN CONNECTIONS	
SUM PORT	2
PORT 1	12
PORT 2	10
PORT 3	6
PORT 4	4
GROUND	1,3,5,7,8,9,11,paddle

### Functional Diagram



# 4 Way-0° Power Splitter/Combiner WP4-ED12616A/5\_13

## Typical Performance Data

FREQ. (MHz)	TOTAL LOSS <sup>1</sup> (dB)				AMP. UNBAL. (dB)	ISOLATION (dB)			PHASE UNBAL. (deg.)	FREQ. (MHz)	VSWR (:1)				
	S-1	S-2	S-3	S-4		1-2	2-3	3-4			S	1	2	3	4
1600.0	15.76	16.12	16.06	15.72	0.40	13.70	13.32	13.70	9.33	1600.0	15.67	1.76	1.80	1.80	1.77
1700.0	14.63	14.97	14.91	14.60	0.38	13.96	13.52	13.96	8.44	1700.0	13.19	1.74	1.79	1.79	1.76
1800.0	13.58	13.90	13.83	13.54	0.36	14.29	13.78	14.29	7.62	1800.0	11.09	1.73	1.77	1.78	1.74
1900.0	12.61	12.91	12.84	12.57	0.34	14.68	14.10	14.68	6.88	1900.0	9.23	1.71	1.76	1.76	1.72
2000.0	11.71	11.99	11.92	11.67	0.32	15.15	14.49	15.15	6.20	2000.0	7.70	1.68	1.73	1.74	1.69
2200.0	10.16	10.40	10.34	10.13	0.28	16.38	15.52	16.40	4.98	2200.0	5.38	1.62	1.67	1.67	1.63
2400.0	8.94	9.14	9.07	8.90	0.24	18.07	16.98	18.19	3.90	2400.0	3.82	1.55	1.60	1.60	1.56
2500.0	8.46	8.64	8.57	8.43	0.22	19.13	17.89	19.34	3.41	2500.0	3.26	1.51	1.56	1.55	1.52
2600.0	8.05	8.21	8.13	8.01	0.20	20.36	18.95	20.67	2.95	2600.0	2.80	1.48	1.52	1.51	1.48
2800.0	7.44	7.56	7.47	7.40	0.16	23.41	21.59	24.02	2.09	2800.0	2.14	1.41	1.43	1.42	1.41
2900.0	7.21	7.31	7.23	7.17	0.14	25.30	23.23	26.06	1.69	2900.0	1.90	1.37	1.39	1.38	1.38
3000.0	7.05	7.13	7.04	7.01	0.12	27.48	25.14	28.26	1.29	3000.0	1.71	1.34	1.35	1.34	1.35
3100.0	6.92	6.98	6.90	6.88	0.10	29.88	27.35	30.40	0.90	3100.0	1.56	1.32	1.32	1.30	1.32
3200.0	6.83	6.87	6.78	6.79	0.09	32.06	29.77	31.79	0.58	3200.0	1.45	1.30	1.28	1.27	1.30
3300.0	6.78	6.80	6.71	6.74	0.09	32.95	31.90	31.81	0.85	3300.0	1.37	1.28	1.26	1.24	1.28
3350.0	6.76	6.77	6.68	6.72	0.09	32.67	32.45	31.36	1.05	3350.0	1.35	1.27	1.24	1.23	1.27
3400.0	6.74	6.75	6.66	6.70	0.09	31.99	32.42	30.73	1.23	3400.0	1.33	1.26	1.23	1.21	1.26
3450.0	6.74	6.73	6.64	6.69	0.09	31.11	31.85	30.03	1.42	3450.0	1.32	1.25	1.21	1.20	1.26
3500.0	6.73	6.72	6.63	6.69	0.10	30.20	30.99	29.32	1.59	3500.0	1.33	1.25	1.21	1.19	1.25
3550.0	6.74	6.72	6.63	6.70	0.11	29.27	29.95	28.62	1.78	3550.0	1.34	1.24	1.19	1.17	1.25
3600.0	6.75	6.72	6.63	6.70	0.12	28.44	28.93	27.95	1.97	3600.0	1.35	1.23	1.18	1.16	1.24
3700.0	6.77	6.72	6.64	6.72	0.13	26.94	27.06	26.71	2.32	3700.0	1.40	1.22	1.16	1.14	1.23
3800.0	6.80	6.74	6.66	6.75	0.14	25.69	25.45	25.61	2.66	3800.0	1.46	1.21	1.14	1.13	1.22
3900.0	6.84	6.77	6.69	6.79	0.15	24.63	24.10	24.64	3.00	3900.0	1.53	1.20	1.13	1.11	1.21
4000.0	6.90	6.82	6.74	6.85	0.16	23.73	22.95	23.75	3.33	4000.0	1.61	1.19	1.11	1.10	1.21
4200.0	7.01	6.92	6.84	6.96	0.18	22.28	21.06	22.23	3.96	4200.0	1.77	1.18	1.09	1.08	1.19
4400.0	7.14	7.04	6.96	7.09	0.18	21.16	19.56	20.97	4.57	4400.0	1.94	1.16	1.07	1.07	1.18
4500.0	7.21	7.10	7.03	7.15	0.18	20.69	18.92	20.43	4.87	4500.0	2.03	1.15	1.07	1.06	1.18
4600.0	7.28	7.16	7.10	7.22	0.18	20.26	18.32	19.94	5.13	4600.0	2.12	1.14	1.07	1.07	1.17
4800.0	7.41	7.29	7.23	7.35	0.18	19.53	17.27	19.11	5.65	4800.0	2.30	1.13	1.07	1.08	1.16
4900.0	7.48	7.36	7.30	7.41	0.18	19.21	16.80	18.76	5.89	4900.0	2.38	1.12	1.08	1.09	1.15
5000.0	7.54	7.42	7.36	7.47	0.18	18.93	16.36	18.46	6.12	5000.0	2.46	1.11	1.09	1.10	1.15
5200.0	7.67	7.56	7.49	7.59	0.17	18.43	15.56	17.95	6.57	5200.0	2.64	1.10	1.11	1.12	1.14
5400.0	7.79	7.68	7.62	7.71	0.17	18.00	14.84	17.57	6.98	5400.0	2.80	1.09	1.13	1.16	1.14
5500.0	7.85	7.74	7.68	7.77	0.17	17.81	14.51	17.41	7.18	5500.0	2.87	1.10	1.15	1.17	1.14
5600.0	7.89	7.80	7.73	7.81	0.17	17.64	14.20	17.25	7.41	5600.0	2.94	1.10	1.18	1.19	1.14
5800.0	7.99	7.90	7.83	7.90	0.16	17.31	13.61	16.98	7.85	5800.0	3.07	1.12	1.21	1.22	1.15
5900.0	8.05	7.97	7.89	7.97	0.16	17.16	13.33	16.85	8.00	5900.0	3.14	1.13	1.23	1.25	1.16
6000.0	8.10	8.02	7.94	8.01	0.16	17.01	13.08	16.73	8.21	6000.0	3.19	1.14	1.26	1.27	1.17
6200.0	8.18	8.11	8.03	8.10	0.16	16.69	12.60	16.44	8.71	6200.0	3.30	1.18	1.31	1.32	1.20
6400.0	8.27	8.21	8.12	8.19	0.15	16.36	12.17	16.12	9.13	6400.0	3.39	1.21	1.37	1.38	1.23
6500.0	8.30	8.25	8.16	8.22	0.14	16.18	11.98	15.95	9.34	6500.0	3.42	1.23	1.39	1.41	1.26
6600.0	8.32	8.28	8.20	8.24	0.12	15.97	11.79	15.75	9.59	6600.0	3.45	1.25	1.43	1.44	1.28
6800.0	8.37	8.35	8.27	8.31	0.10	15.53	11.45	15.30	10.07	6800.0	3.50	1.30	1.50	1.51	1.33
6900.0	8.39	8.37	8.31	8.33	0.08	15.29	11.29	15.06	10.36	6900.0	3.53	1.32	1.54	1.54	1.35
7000.0	8.40	8.39	8.34	8.34	0.07	15.04	11.15	14.81	10.58	7000.0	3.54	1.34	1.58	1.58	1.38
7200.0	8.42	8.41	8.39	8.37	0.04	14.51	10.88	14.30	11.05	7200.0	3.56	1.39	1.65	1.65	1.43
7400.0	8.42	8.43	8.43	8.38	0.05	13.96	10.67	13.78	11.55	7400.0	3.56	1.43	1.73	1.73	1.48
7500.0	8.43	8.44	8.45	8.40	0.05	13.70	10.58	13.52	11.83	7500.0	3.55	1.45	1.76	1.77	1.51
7600.0	8.43	8.45	8.47	8.41	0.06	13.43	10.50	13.26	12.15	7600.0	3.55	1.47	1.81	1.81	1.53
7800.0	8.45	8.47	8.50	8.43	0.06	12.92	10.36	12.79	12.73	7800.0	3.53	1.52	1.87	1.88	1.58
7900.0	8.45	8.47	8.50	8.44	0.06	12.68	10.30	12.56	13.00	7900.0	3.52	1.54	1.91	1.92	1.61
8000.0	8.47	8.48	8.49	8.45	0.04	12.46	10.24	12.33	13.37	8000.0	3.52	1.57	1.94	1.95	1.63

<sup>1</sup>Total Loss = Insertion Loss + 6dB Splitter Loss



# 4 Way-0° Power Splitter/Combiner WP4-ED12616A/5\_13

## Typical Performance Curves

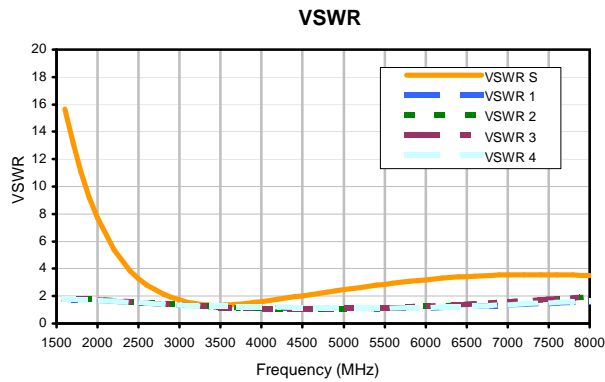
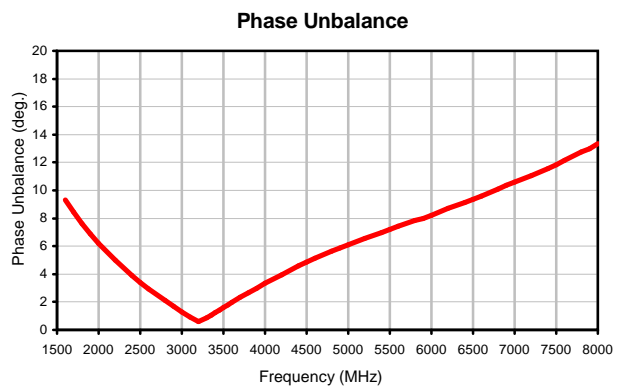
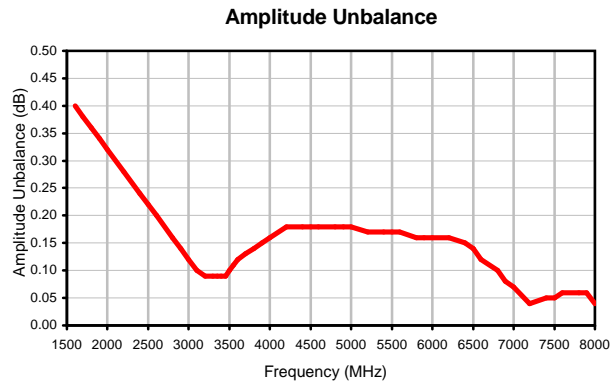
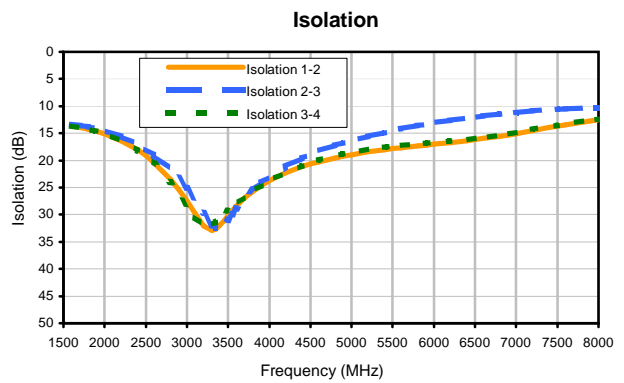
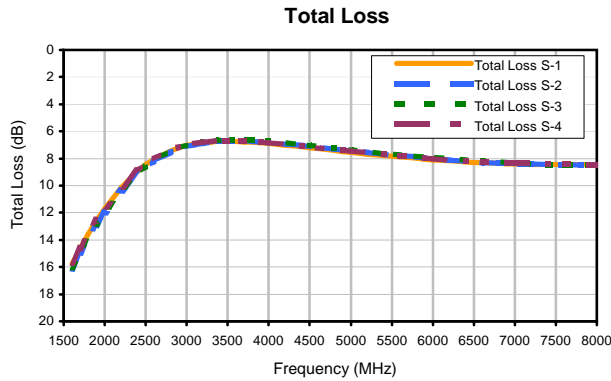

### Outline Dimensions

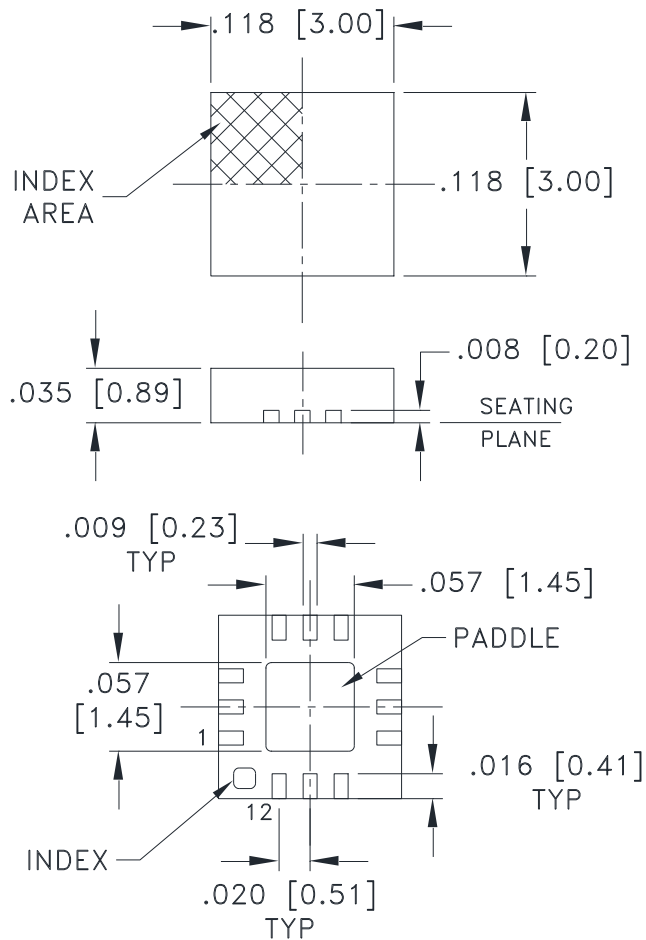

### PCB Land Pattern

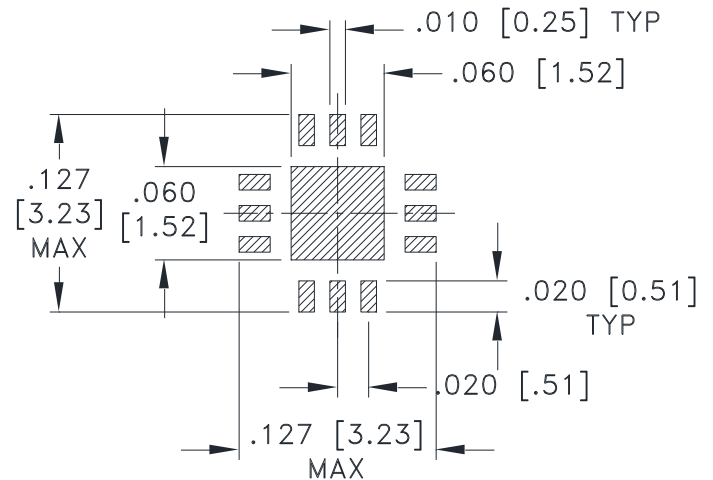

SUGGESTED LAYOUT,  
TOLERANCE TO BE WITHIN  $\pm .002$

**Weight: .02 Grams**

**Dimensions are in inches (mm). Tolerances: 2Pl.  $\pm .01$ ; 3 Pl.  $\pm .004$**

#### Notes:

1. Case material: Plastic.
2. Termination finish:
  - For RoHS Case Styles: Tin-Silver alloy plate over Nickel barrier or Matte-Tin. All models, (+) suffix. See Data sheet.
  - For RoHS-5 Case Styles: Tin-Lead plate. All models, no (+) suffix.



INTERNET <http://www.minicircuits.com>

P.O. Box 350166, Brooklyn, New York 11235-0003 (718) 934-4500 Fax (718) 332-4661

Distribution Centers NORTH AMERICA 800-654-7949 • 417-335-5935 • Fax 417-335-5945 • EUROPE 44-1252-832600 • Fax 44-1252-837010

Mini-Circuits ISO 9001 & ISO 14001 Certified

# Tape & Reel Packaging TR-F66

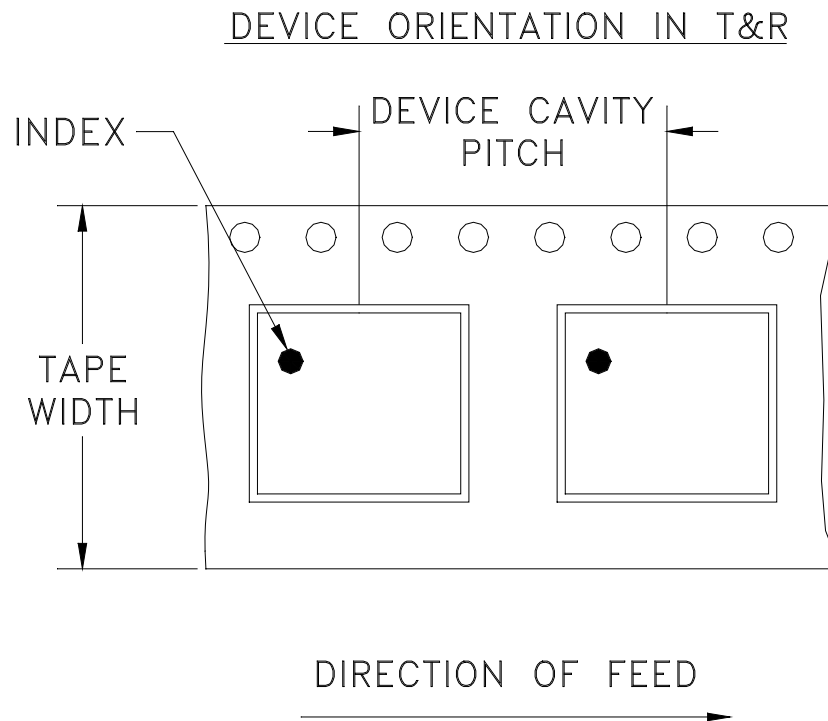

Tape Width, mm	Device Cavity Pitch, mm	Reel Size, inches	Devices per Reel see note	
8	4	7	Small quantity standard	20
				50
				100
				200
				500
		7	Standard	1000, 2000, 3000

Note: Please consult individual model data sheet to determine device per reel availability.

Mini-Circuits carrier tape materials provide protection from ESD (Electro-Static Discharge) during handling and transportation. Tapes are static dissipative and comply with industry standards EIA-481/EIA-541.

Go to: [www.minicircuits.com/pages/pdfs/tape.pdf](http://www.minicircuits.com/pages/pdfs/tape.pdf)

**Mini-Circuits®**

INTERNET <http://www.minicircuits.com>

P.O. Box 350166, Brooklyn, New York 11235-0003 (718) 934-4500 Fax (718) 332-4661

Distribution Centers NORTH AMERICA 800-654-7949 • 417-335-5935 • Fax 417-335-5945 • EUROPE 44-1252-832600 • Fax 44-1252-837010

Mini-Circuits ISO 9001 & ISO 14001 Certified

THIRD ANGLE PROJECTION

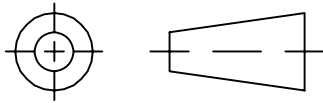

REVISIONS

REV	ECN No.	DESCRIPTION	DATE	DR	AUTH
OR	M109251	NEW RELEASE	01/11/07	PW	WP
A	M112849	UPDATED NOTE 3	08/03/07	AV	WP

SUGGESTED MOUNTING CONFIGURATION FOR DQ1225 CASE STYLE, "rx" PIN CONNECTION

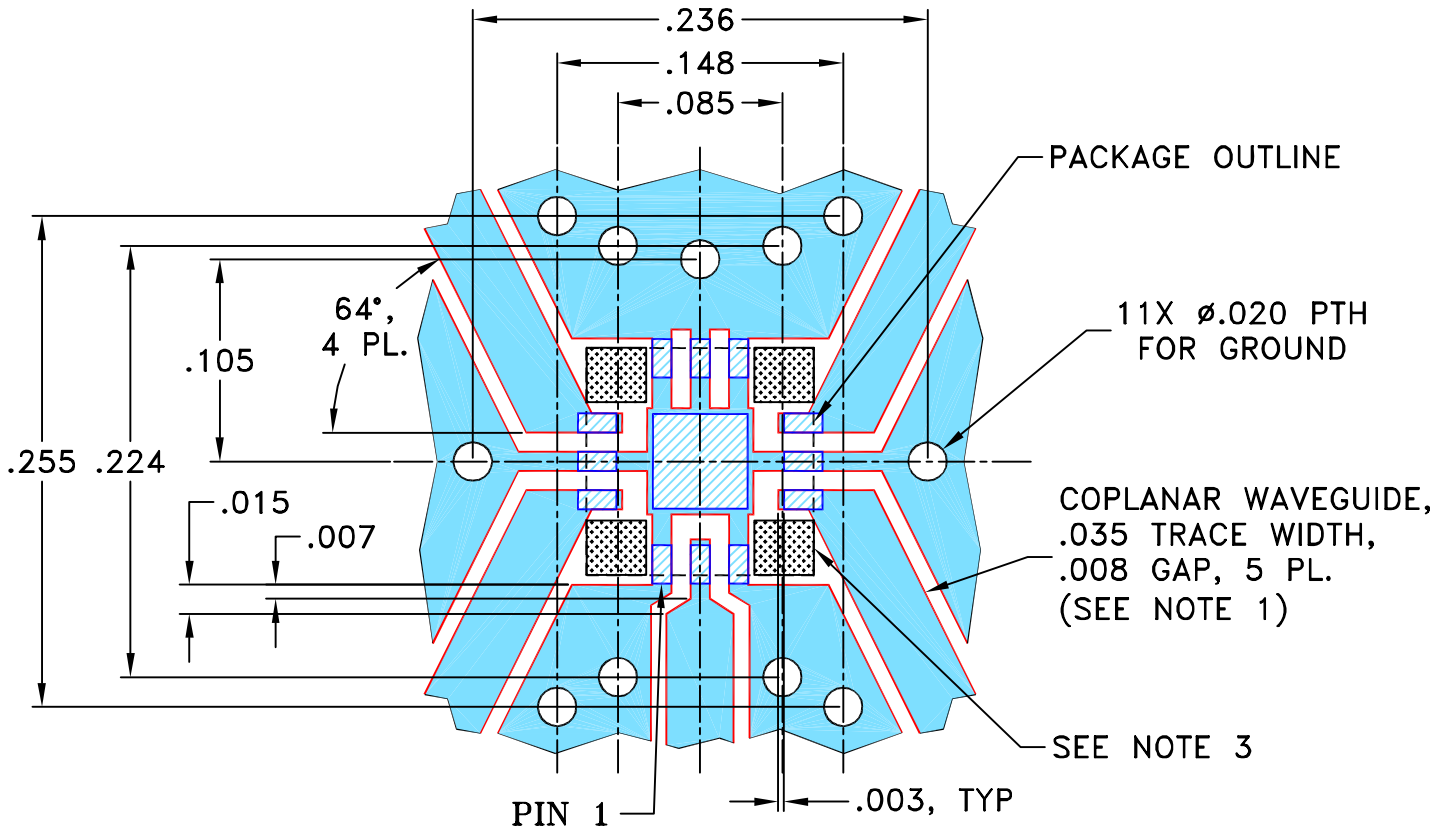

NOTES:

1. TRACE WIDTH IS SHOWN FOR ROGERS R04350B WITH DIELECTRIC THICKNESS  $.020'' \pm .0015''$ ; COPPER: 1/2 OZ. EACH SIDE. FOR OTHER MATERIALS TRACE WIDTH AND GAP MAY NEED TO BE MODIFIED.
2. BOTTOM SIDE OF THE PCB IS CONTINUOUS GROUND PLANE.
3. SIGNAL TRACES ARE NOT ALLOWED INSIDE HATCHED AREAS (APPROX.  $.030 \times .030$ ) AT 4 PLACES AS SHOWN.

- DENOTES PCB COPPER LAYOUT WITH SMOBC (SOLDER MASK OVER BARE COPPER)
- DENOTES COPPER LAND PATTERN FREE OF SOLDER MASK

UNLESS OTHERWISE SPECIFIED	INITIALS	DATE
DRAWN	PW	01/10/07
CHECKED	IL	01/11/07
APPROVED	WP	01/11/07

**Mini-Circuits®** 13 Neptune Avenue  
Brooklyn NY 11235

PL, rx, DQ1225, WP4, TB-395+

Mini-Circuits®  
THIS DOCUMENT AND ITS CONTENTS ARE THE PROPERTY OF MINI-CIRCUITS. EXCEPT FOR USE EXPRESSLY GRANTED, IN WRITING, TO ITS VENDORS, VENDEE AND THE UNITED STATES GOVERNMENT, MINI-CIRCUITS RESERVES ALL PROPRIETARY DESIGN, USE, MANUFACTURING AND REPRODUCTION RIGHTS THERETO. THESE CONTENTS SHALL NOT BE USED, DUPLICATED OR DISCLOSED TO ANY OUTSIDE PARTY, IN WHOLE OR IN PART, WITHOUT WRITTEN PERMISSION OF MINI-CIRCUITS.

SIZE	CODE IDENT	DRAWING NO:	REV:
A	15542	98-PL-259	A
FILE:	98PL259	SCALE:	10:1
SHEET:	1	OF	1

# Evaluation Board and Circuit

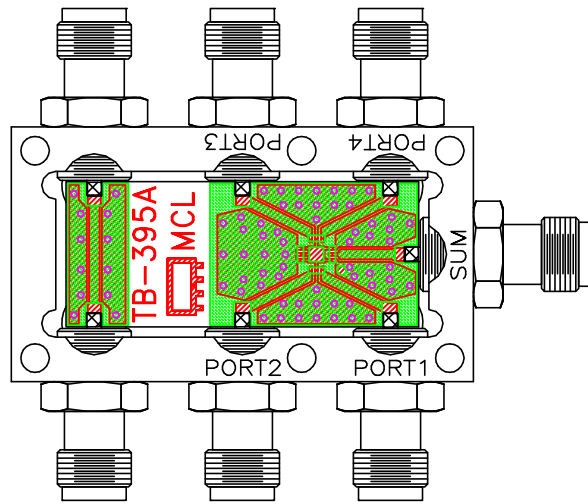

TB-395+

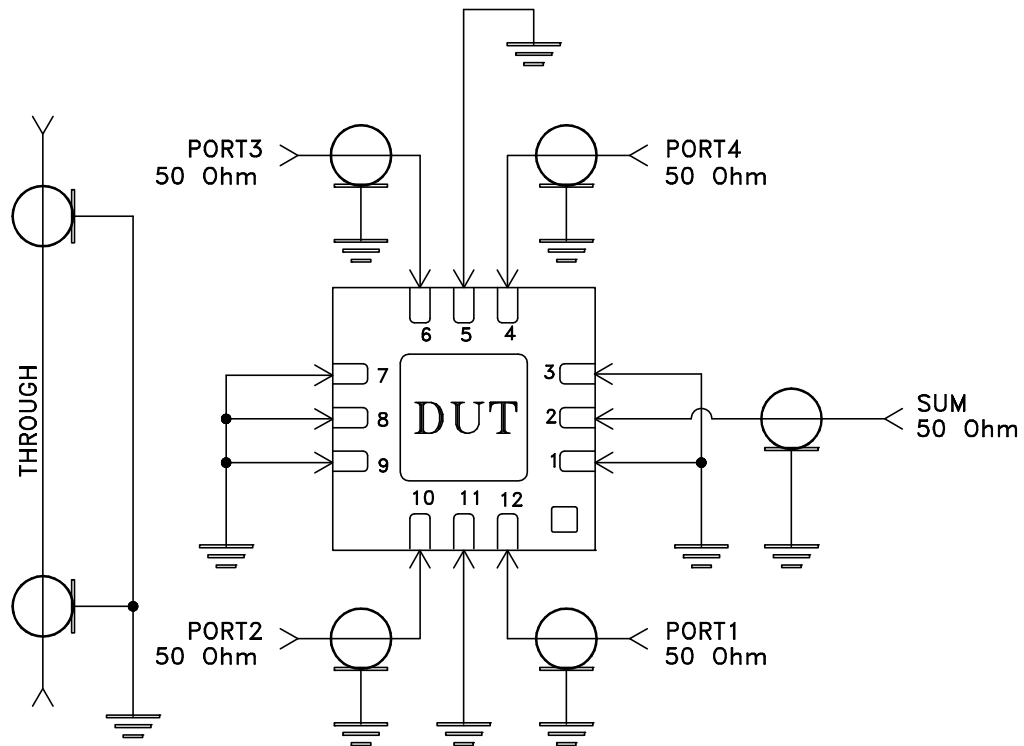

Schematic Diagram

## Notes:

1. SMA Female connectors.
2. PCB Material: Rogers R04350 or equivalent,  
Dielectric Constant=3.5, Thickness=.020 inch.

 **Mini-Circuits®**

All Mini-Circuits products are manufactured under exacting quality assurance and control standards, and are capable of meeting published specifications after being subjected to any or all of the following physical and environmental test.

Specification	Test/Inspection Condition	Reference/Spec
Operating Temperature	-40° to 85° C Ambient Environment	Individual Model Data Sheet
Storage Temperature	-65° to 150° C Ambient Environment	Individual Model Data Sheet
Autoclave	15 psig, 100% RH, 121°C, 96 hours	JESD22-A102-C, Condition C
Temperature Cycling	-65° to 150°C, 100 cycles	JESD22-A104
Temperature Humidity	85°C/ 85% RH, 168 hours	JESD22-113
Solder Reflow Heat	Sn-Pb Eutetic Process: 240°C peak Pb-Free Process: 260°C peak	J-STD-020, Table 4-1, 4-2 and 5-2; Figure 5-1
Moisture Sensitivity: Level 1	Bake at 125°C for 24 hours Soak at 85°C/85% RH for 168 hours, Reflow 3 cycles at 240°C peak (Non-RoHS) or 260°C (RoHS)	J-STD-020
Solderability	10X magnification, 95% coverage	JESD22-B102, Method 1: Dip and Look Test
Mechanical Shock	50g, 11 ms, 1/2-sine, 18 shocks: 3 each direction, each of 3 axes	MIL-STD-202, Method 213, Condition A
Vibration (High Frequency)	20g peak, 10-2000 Hz, 12 times in each of three perpendicular directions (total 36)	MIL-STD-202, Method 204, Condition D