

# Coaxial Attenuator/Switch

## ZFAS-2000+

50Ω Bi-Phase 100 to 2000 MHz

### Maximum Ratings

Operating Temperature	-55°C to 100°C
Storage Temperature	-55°C to 100°C
Control Current	30mA
Permanent damage may occur if any of these limits are exceeded.	

### Coaxial Connections

INPUT	2
OUTPUT	1
CONTROL	3

### Outline Drawing

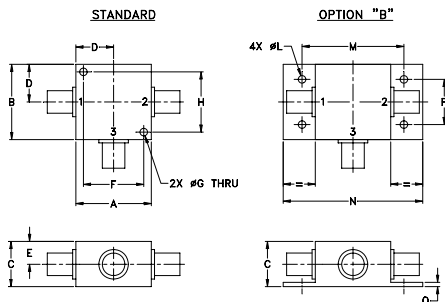

### Outline Dimensions (inch/mm)

A	B	C	D	E	F	G	H
1.25	1.25	.75	.63	.38	1.00	.125	1.000
31.75	31.75	19.05	16.00	9.65	25.40	3.18	25.40
J	K	L	M	N	P	Q	wt
--	--	.125	1.688	2.18	.75	.07	grams
--	--	3.18	42.88	55.37	19.05	1.78	70.0

### Features

- wideband, 100 to 2000 MHz
- rugged shielded case

### Applications

- bi-phase modulator



CASE STYLE: K18

Connectors Model  
**SMA** ZFAS-2000+  
**BRACKET (OPTION "B")**

**+RoHS Compliant**

The +Suffix identifies RoHS Compliance. See our web site for RoHS Compliance methodologies and qualifications

### Attenuator/Switch Electrical Specifications

FREQUENCY (MHz)	INSERTION LOSS (dB) ±20 mA	MAX. INPUT PWR (dBm) ±20mA	IN-OUT ISOLATION (dB) 0 mA						BI-PHASE X̄ (±20 mA) Typ.						
			L		M		U		Δ AMP (dB)		Phase (deg.) deviation from 180°				
IN f <sub>L</sub> -f <sub>U</sub>	CON	Mid-Band m Typ. Max.	Total Range Typ. Max.	1 dB compr.	no damage	Typ.	Min.	Typ.	Min.	Typ.	Min.	m	Total Range	m	Total Range
100-2000	DC-0.5	4.2 6.5	5.4 7.5	19*	25	30	22	—	—	26	20	0.3	0.4	5.0	8.0

L = low range [f<sub>L</sub> to 10 f<sub>L</sub>] M = mid range [10 f<sub>L</sub> to f<sub>U</sub>/2] U = upper range [f<sub>U</sub>/2 to f<sub>U</sub>] m = [2 f<sub>L</sub> to f<sub>U</sub>/2]  
 \* 15 dBm from 100-800 MHz.

Performance specifications apply for input power up to 10 dB below stated 1 dB compression.

### suggested control port biasing configuration

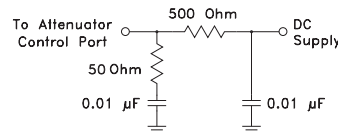

### electrical schematic

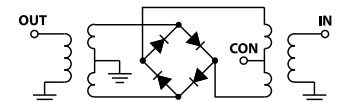

### Typical Performance Data

Freq. (MHz)	I. Loss (dB) at 20mA	±Control ΔΔAMP (dB)	20mA ΔΔPhase (deg.)	Isolation (dB)			Input R. Loss (dB)	Control Current (mA)	Attenuation (dB)			Phase Δ ref at 15mA Ctrl			Input VSWR		
				(in-out)	(in-con)	(in-con)			100 MHz	1000 MHz	2000 MHz	100 MHz	1000 MHz	2000 MHz	100 MHz	1000 MHz	2000 MHz
X̄	σ	X̄	X̄	X̄	X̄	X̄											
100.0	3.76	0.006	0.02	179.4	46	48	9.5	0.0000	51.0	38.9	34.4	89.6	18.6	46.6	1.6	4.7	2.9
137.1	3.72	0.003	0.01	179.0	43	44	10.2	0.0001	48.5	37.0	33.9	91.3	12.9	42.2	1.6	4.7	2.9
301.5	3.55	0.001	0.03	178.2	36	34	11.0	0.0002	46.3	35.1	33.2	89.8	8.7	35.1	1.6	4.6	2.9
383.8	3.61	0.001	0.04	177.7	34	32	10.5	0.0003	44.1	33.6	32.7	85.5	5.8	31.0	1.5	4.6	2.9
503.4	3.85	0.010	0.08	177.1	32	30	9.3	0.0004	42.3	32.4	32.1	84.8	2.4	27.0	1.5	4.6	2.9
630.4	4.17	0.027	0.18	176.4	30	29	7.9	0.0005	39.1	30.8	31.2	78.5	-1.4	21.2	1.5	4.6	2.9
757.5	4.47	0.059	0.21	176.3	30	31	6.9	0.0006	36.5	29.7	30.6	71.5	-4.8	16.8	1.5	4.5	2.9
802.4	4.54	0.061	0.22	176.4	30	31	6.7	0.0007	30.2	26.8	28.7	53.5	-12.0	6.9	1.5	4.4	2.8
899.5	4.91	0.107	0.27	176.1	30	30	6.3	0.0008	25.5	24.0	26.3	43.0	-15.6	-0.9	1.4	4.2	2.7
996.7	4.96	0.114	0.28	175.9	29	28	6.2	0.0011	22.0	21.2	23.6	36.6	-16.4	-5.9	1.4	4.0	2.6
1004.2	4.94	0.118	0.28	175.8	29	28	6.2	0.0016	18.4	18.1	20.3	31.0	-16.0	-8.8	1.3	3.7	2.4
1131.3	5.57	0.162	0.36	175.7	30	26	6.4	0.0032	14.1	14.1	15.9	24.3	-13.7	-9.8	1.2	3.3	2.0
1258.3	5.56	0.105	0.36	175.5	30	24	7.0	0.0058	11.3	11.5	13.0	19.5	-11.1	-8.9	1.2	3.1	1.8
1377.9	5.69	0.045	0.37	175.5	30	24	7.7	0.0106	9.1	9.5	10.6	14.8	-8.6	-7.5	1.3	3.0	1.6
1497.5	5.26	0.053	0.33	175.2	28	21	8.7	0.0226	6.9	7.7	8.3	9.5	-5.5	-5.4	1.5	2.9	1.4
1632.1	5.38	0.045	0.27	174.7	28	20	10.0	0.0381	5.9	6.9	7.2	6.7	-4.0	-4.0	1.6	2.9	1.4
1699.4	5.20	0.068	0.29	174.2	28	20	10.8	0.1031	4.8	6.0	6.0	3.2	-2.0	-2.1	1.8	3.0	1.5
1751.7	5.49	0.068	0.27	174.2	28	21	11.3	0.3098	4.3	5.5	5.4	1.3	-0.9	-1.0	1.9	3.0	1.6
1901.2	5.22	0.090	0.23	173.0	28	22	12.4	1.5487	4.0	5.3	5.0	0.4	-0.4	-0.4	2.0	3.0	1.7
2000.0	5.57	0.156	0.25	172.7	28	23	12.5	15.1120	3.9	5.2	4.9	0.1	-0.1	0.0	2.0	3.1	1.7

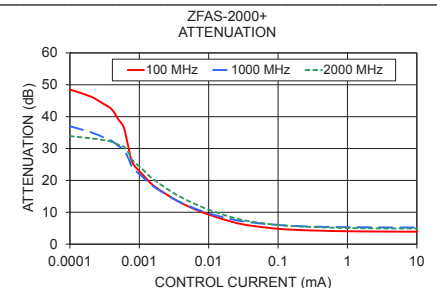
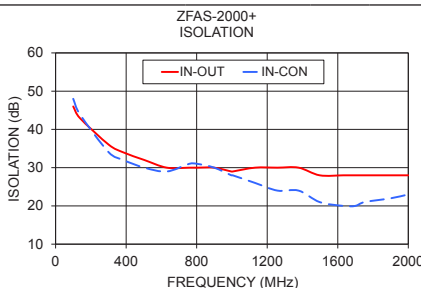
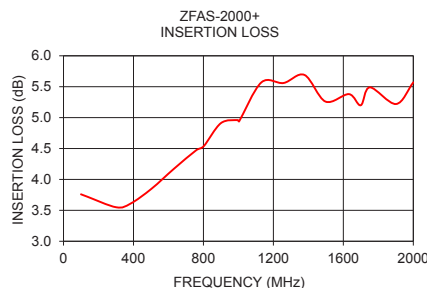

### Notes

- Performance and quality attributes and conditions not expressly stated in this specification document are intended to be excluded and do not form a part of this specification document.
- Electrical specifications and performance data contained in this specification document are based on Mini-Circuit's applicable established test performance criteria and measurement instructions.
- The parts covered by this specification document are subject to Mini-Circuit's standard limited warranty and terms and conditions (collectively, "Standard Terms"); Purchasers of this part are entitled to the rights and benefits contained therein. For a full statement of the Standard Terms and the exclusive rights and remedies thereunder, please visit Mini-Circuit's website at [www.minicircuits.com/MCLStore/terms.jsp](http://www.minicircuits.com/MCLStore/terms.jsp)



### Outline Dimensions

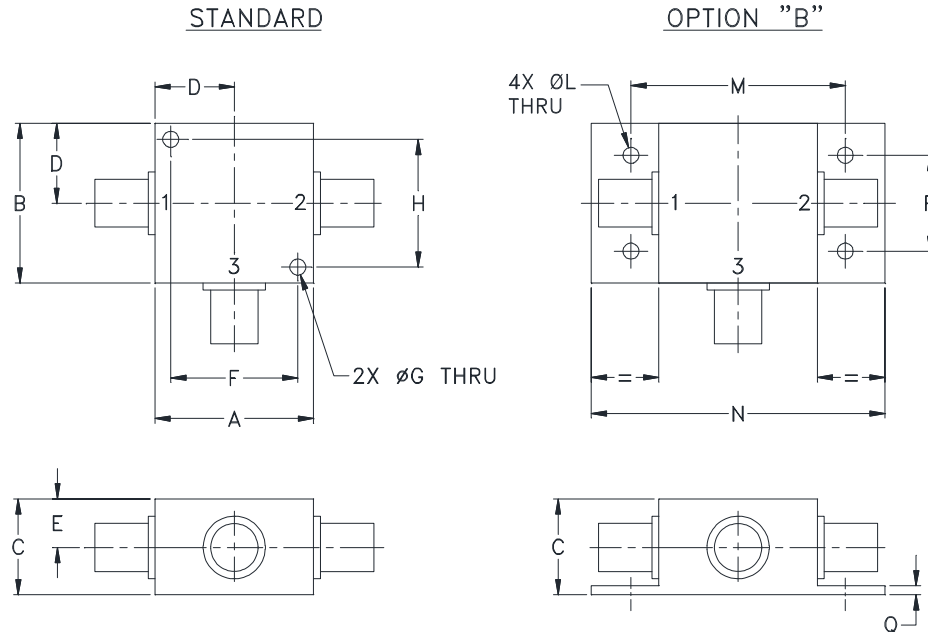

CASE#	A	B	C	D	E	F	G	H	J	K	L	M	N
K18	1.25 (31.75)	1.25 (31.75)	.75 (19.05)	.63 (16.00)	.38 (9.65)	1.000 (25.40)	.125 (3.18)	1.000 (25.40)	--	--	.125 (3.18)	1.688 (42.88)	2.18 (55.37)

CASE#	P	Q	WT. GRAMS
K18	.75 (19.05)	.07 (1.78)	70.0

Dimensions are in inches (mm). Tolerances: 2 Pl.  $\pm .03$ ; 3 Pl.  $\pm .015$

#### Notes:

- Case material: Aluminum alloy.
- Case finish:  
For RoHS Case Styles: Clear chemical conversion coating, non-chrome or trivalent chrome based.
- Mounting bracket available on request. Add suffix B to part number.
- For port marking 1, 2, and 3 see specifications data sheet.
- For bracket version, option B, dimension "C" changes from .75 to .94 inches when connectors are type N.
- Refer to the individual model data sheet for the type of connectors available.

**Mini-Circuits®**

INTERNET <http://www.minicircuits.com>

P.O. Box 350166, Brooklyn, New York 11235-0003 (718) 934-4500 Fax (718) 332-4661

Distribution Centers NORTH AMERICA 800-654-7949 • 417-335-5935 • Fax 417-335-5945 • EUROPE 44-1252-832600 • Fax 44-1252-837010

Mini-Circuits ISO 9001 & ISO 14001 Certified



All Mini-Circuits products are manufactured under exacting quality assurance and control standards, and are capable of meeting published specifications after being subjected to any or all of the following physical and environmental test.

<b>Specification</b>	<b>Test/Inspection Condition</b>	<b>Reference/Spec</b>
Operating Temperature	-55° to 100°C Ambient Environment	Individual Model Data Sheet
Storage Temperature	-55° to 100° C Ambient Environment	Individual Model Data Sheet
Barometric Pressure	100,000 Feet	MIL-STD-202, Method 105, Condition D
Humidity	90% RH, 65°C Units may require bake-out after humidity to restore full performance.	MIL-STD-202, Method 103
Thermal Shock	-65° to 125°C, 5 cycles	MIL-STD-202, Method 107, Condition B
Vibration (High Frequency)	20g peak, 10-2000 Hz, 12 times in each of three perpendicular directions (total 36)	MIL-STD-202, Method 204, Condition D
Mechanical Shock	100g, 6ms sawtooth, 3 shocks each direction 3 axes (total 18)	MIL-STD-202, Method 213, Condition I