

6dB DC Pass **NON-CATALOG** High Power Bi-Directional Coupler **ZGBDC6-362HP+**

50Ω Up to 250W 380 to 3600 MHz

The Big Deal

- High Power Handling: 250W
- Low Insertion Loss: 0.20 dB*
- Rugged IP67 Weatherproof case



CASE STYLE: HT1760

Product Overview

Mini-Circuits ZGBDC6-362HP+ broadband high power bi-directional coupler offers excellent performance across a wide range of popular frequency bands. Built using low loss suspended substrate construction, the ZGBDC6-362HP+ can pass up to 3A of DC current from input to output and handle up to 250W CW. Rugged sealed construction makes this coupler ideal for use in field applications or remote monitoring sites; however, it is also ideal for high power lab testing.

Key Features

Feature	Advantages
Excellent Insertion Loss , 0.20 dB Typ*	With extremely low insertion loss, this coupler is ideal for critical high power applications.
Ultra High Return Loss, 28 dB Typ	Outstanding Return loss makes this coupler ideal for sensitive power measurement and other signal distribution applications.
High Power Handling, 250W	Up to 250W CW power handling, combined with low insertion loss and excellent VSWR support operation in high power applications such as transmitters, base stations and high power device characterization.
Wide bandwidth	300-3000 MHz coverage includes many popular cellular, WiMAX, LTE, ISM, satellite, P2P, aviation, maritime, defense, and radar bands
Excellent Directivity and Coupling Flatness	Typical 26 dB directivity and ± 1.3 dB of Coupling flatness provides accurate signal sampling of forward or reflected power.
Passes DC Current, 3A	Capable of passing 3A current, input to output; this coupler is suited for application using remote antenna control or other remote motorized requirements.
IP67 Weatherproof Case	With an Ingress Protection rating of IP67, the ZGBDC6-362HP+ is designed to operate in harsh outdoor applications.

*Does not include coupling loss

Notes

- A. Performance and quality attributes and conditions not expressly stated in this specification document are intended to be excluded and do not form a part of this specification document.
 B. Electrical specifications and performance data contained in this specification document are based on Mini-Circuit's applicable established test performance criteria and measurement instructions.
 C. The parts covered by this specification document are subject to Mini-Circuits standard limited warranty and terms and conditions (collectively, "Standard Terms"); Purchasers of this part are entitled to the rights and benefits contained therein. For a full statement of the Standard Terms and the exclusive rights and remedies thereunder, please visit Mini-Circuits' website at www.minicircuits.com/MCLStore/terms.jsp



6dB DC Pass High Power Bi-Directional Coupler

ZGBDC6-362HP+

50Ω Up to 250W 380 to 3600 MHz

Maximum Ratings

Operating Temperature	-55°C to 100°C
Storage Temperature	-55°C to 100°C
DC Current	3A

Permanent damage may occur if any of these limits are exceeded

Coaxial Connections

INPUT	IN
OUTPUT	OUT
COUPLED IN	CPL IN
COUPLED OUT	CPL OUT

Outline Drawing

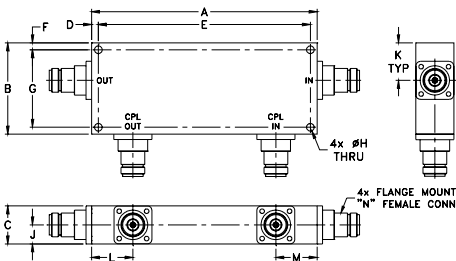

Outline Dimensions (inch/mm)

A	B	C	D	E	F	G
5.93	2.40	1.00	.18	5.565	.18	2.040
150.62	60.96	25.40	4.57	141.35	4.57	51.82
H	J	K	L	M		wt
.200	.50	.99	1.09	1.09		grams
5.08	12.70	25.15	27.69	27.69		700.0

IP protection classification: IP67

Features

- wide frequency range, can be used for 380 - 4000 GHz
- good coupling flatness, ± 1.3 dB typ. (1000-4000 MHz)
- high directivity, 24.7 dB typ.
- good VSWR, 1.18:1 typ.
- high power, up to 250W
- DC current pass through input to output
- IP67 weather proof case

Applications

- cellular
- lab use
- WiMAX
- PCN
- GSM
- ISM



CASE STYLE: HT1760

Connectors Model
N-Type ZGBDC6-362HP+

+RoHS Compliant

The +Suffix identifies RoHS Compliance. See our web site for RoHS Compliance methodologies and qualifications

Electrical Specifications at 25°C

Parameter	Frequency (MHz)	Min.	Typ.	Max.	Units
Operating Frequency		380		3600	MHz
Coupling	380-600	—	7.2 \pm 1.4	—	
	600-2700	—	6.3 \pm 0.6	—	dB
	2700-3600	—	6.3 \pm 0.4	—	
Coupling Flatness	380-600	—	—	± 1.25	
	600-2700	—	—	± 0.75	dB
	2700-3600	—	—	± 0.4	
Mainline Loss ¹	380-600	—	0.06	0.2	
	600-2700	—	0.20	0.5	dB
	2700-3600	—	0.29	0.6	
Directivity	380-600	20	29	—	
	600-2700	20	26	—	dB
	2700-3600	15.5	20	—	
Return Loss	380-600	—	30.3	—	
	600-2700	—	28.3	—	dB
	2700-3600	—	24.7	—	
Input Power ²	380-600	—	—	250	
	600-2700	—	—	250	W
	2700-3600	—	—	150	

1. Does not include coupling loss.

2. At 25°C with no DC current. Derate linearly to 100W (380-2700 MHz) and to 64W (2700-3600 MHz) from 25°C to 100°C. Output load VSWR 2.0:1 max.

Electrical Schematic

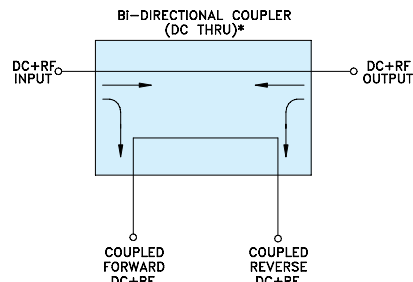

* ELECTRICAL SCHEMATIC IS FOR BI-DIRECTIONAL COUPLER WITHOUT INTERNAL TRANSFORMERS AND RESISTORS.

Notes

- Performance and quality attributes and conditions not expressly stated in this specification document are intended to be excluded and do not form a part of this specification document.
- Electrical specifications and performance data contained in this specification document are based on Mini-Circuit's applicable established test performance criteria and measurement instructions.
- The parts covered by this specification document are subject to Mini-Circuits standard limited warranty and terms and conditions (collectively, "Standard Terms"); Purchasers of this part are entitled to the rights and benefits contained therein. For a full statement of the Standard Terms and the exclusive rights and remedies thereunder, please visit Mini-Circuits' website at www.minicircuits.com/MCLStore/terms.jsp



www.minicircuits.com P.O. Box 350166, Brooklyn, NY 11235-0003 (718) 934-4500 sales@minicircuits.com

REV. C
M166133
ED-14818A
ZGBDC6-362HP+
AV/CP/AM
181204
Page 2 of 3

Typical Performance Data

Frequency (MHz)	Mainline Loss (dB) In-Out	Coupling (dB)		Directivity (dB)		Return Loss (dB)			
		In-Cpl Fwd	Out-Cpl Rev	Out-Cpl Fwd	In-Cpl Rev	In	Out	Cpl Fwd	Cpl Rev
50.00	0.02	23.58	23.60	37.44	35.37	46.43	46.24	49.71	42.63
380.00	0.05	8.03	8.03	33.77	35.03	38.51	40.78	41.19	44.66
600.00	0.08	6.40	6.42	36.71	38.65	28.90	29.70	29.50	30.28
1500.00	0.13	6.10	6.24	36.81	45.85	39.67	40.06	37.72	34.73
2000.00	0.18	6.38	6.59	29.85	34.61	26.25	28.06	30.47	36.38
2500.00	0.22	6.22	6.43	28.10	27.65	25.20	30.28	25.70	29.08
2700.00	0.24	6.39	6.64	25.92	29.36	24.36	27.96	27.29	29.33
3000.00	0.25	6.56	6.85	24.27	29.77	24.06	27.42	30.62	43.64
3600.00	0.33	6.55	6.79	18.26	20.19	20.97	29.10	23.82	27.86
4000.00	0.52	6.88	7.06	19.97	24.58	14.46	16.17	17.07	20.19

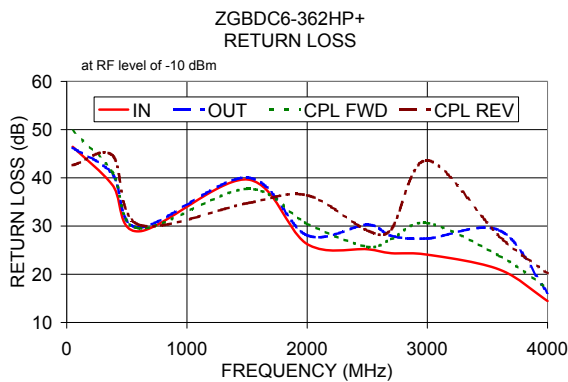
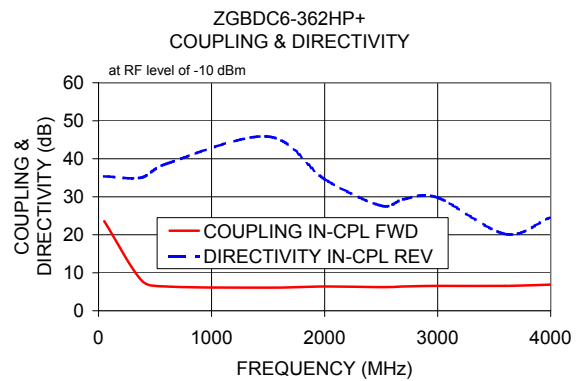
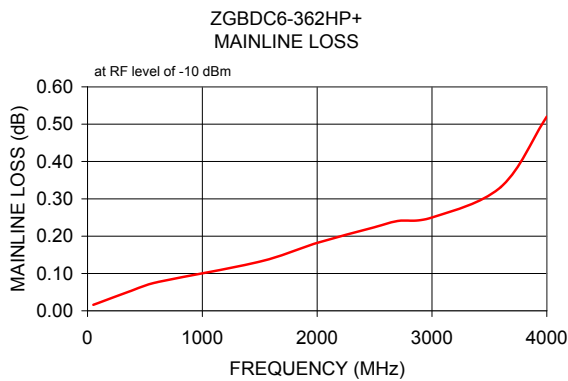

Notes

- A. Performance and quality attributes and conditions not expressly stated in this specification document are intended to be excluded and do not form a part of this specification document.
- B. Electrical specifications and performance data contained in this specification document are based on Mini-Circuit's applicable established test performance criteria and measurement instructions.
- C. The parts covered by this specification document are subject to Mini-Circuits standard limited warranty and terms and conditions (collectively, "Standard Terms"); Purchasers of this part are entitled to the rights and benefits contained therein. For a full statement of the Standard Terms and the exclusive rights and remedies thereunder, please visit Mini-Circuits' website at www.minicircuits.com/MCLStore/terms.jsp



DC PASS
Bi-Directional Coupler
Typical Performance Data

ZGBDC6-362HP+

FREQ. (MHz)	INSERTION LOSS ⁽¹⁾		COUPLING		DIRECTIVITY		RETURN LOSS			
	(dB)		(dB)		(dB)		(dB)			
	IN-OUT	FWD-REV	IN-FWD	OUT-REV	IN-REV	OUT-FWD	IN	OUT	FWD	REV
50.0	0.02	0.02	23.58	23.60	35.37	37.44	46.43	46.24	49.71	42.63
60.0	0.02	0.02	22.02	21.98	38.08	42.96	43.74	43.80	42.54	41.58
70.0	0.02	0.01	20.70	20.69	44.23	41.90	43.61	43.15	41.93	41.71
80.0	0.02	0.02	19.57	19.55	43.47	41.19	42.87	42.09	40.38	40.63
90.0	0.02	0.02	18.58	18.57	43.09	40.24	41.94	41.35	39.52	39.71
100.0	0.02	0.02	17.70	17.68	42.43	40.60	41.32	40.77	39.41	39.25
150.0	0.03	0.03	14.38	14.38	39.36	38.25	39.80	38.92	38.11	37.83
200.0	0.03	0.03	12.16	12.16	37.94	36.54	39.47	38.27	38.35	37.75
250.0	0.04	0.04	10.56	10.56	36.70	35.20	40.05	38.46	40.08	38.71
300.0	0.04	0.04	9.37	9.37	35.47	34.40	42.26	39.90	42.93	40.73
350.0	0.05	0.05	8.46	8.46	35.09	33.70	40.89	41.31	44.10	44.27
360.0	0.05	0.05	8.31	8.31	35.05	33.71	40.03	41.36	43.29	44.72
370.0	0.05	0.05	8.17	8.17	35.14	33.77	39.28	41.05	42.19	44.87
380.0	0.05	0.05	8.03	8.03	35.03	33.77	38.51	40.78	41.19	44.66
390.0	0.05	0.06	7.91	7.91	35.15	33.68	37.53	40.32	40.24	44.06
400.0	0.05	0.05	7.78	7.78	35.26	33.46	36.65	39.70	39.40	43.17
450.0	0.06	0.06	7.26	7.27	35.60	34.18	33.40	36.17	35.05	38.15
500.0	0.07	0.07	6.87	6.88	36.06	34.68	31.34	33.25	32.24	34.37
550.0	0.07	0.08	6.59	6.61	36.84	35.16	29.85	30.99	30.56	31.95
600.0	0.08	0.09	6.40	6.42	38.65	36.71	28.90	29.70	29.50	30.28
650.0	0.08	0.09	6.26	6.30	41.57	39.34	28.53	28.89	29.03	29.36
700.0	0.08	0.10	6.20	6.24	46.05	43.31	28.62	28.86	29.06	29.14
800.0	0.09	0.11	6.20	6.26	49.27	49.42	30.27	30.66	30.77	31.01
850.0	0.09	0.11	6.24	6.31	41.36	41.46	31.97	33.02	32.61	33.48
900.0	0.09	0.12	6.30	6.38	38.04	37.56	34.29	36.54	35.79	37.55
950.0	0.09	0.12	6.36	6.44	35.05	34.94	37.85	39.37	39.94	40.97
1000.0	0.09	0.13	6.40	6.51	33.50	33.24	41.48	36.57	47.12	37.89
1050.0	0.10	0.14	6.44	6.55	32.05	32.40	41.84	34.15	43.29	34.61
1100.0	0.10	0.15	6.45	6.57	31.48	31.97	39.95	32.48	38.59	33.01
1150.0	0.11	0.15	6.44	6.57	31.18	32.11	37.71	32.48	36.40	32.54
1200.0	0.11	0.15	6.40	6.53	31.37	32.91	37.56	33.19	35.32	33.53
1250.0	0.11	0.16	6.35	6.49	32.01	34.54	38.19	35.25	35.31	35.74
1300.0	0.12	0.16	6.29	6.43	33.50	36.69	40.39	38.78	35.97	40.06
1350.0	0.12	0.17	6.23	6.37	34.82	40.49	43.09	43.89	37.11	44.50
1400.0	0.12	0.17	6.17	6.31	38.19	44.30	45.82	48.48	38.28	41.39
1450.0	0.13	0.18	6.13	6.27	40.97	40.96	43.97	42.87	38.61	37.64
1500.0	0.13	0.18	6.10	6.24	45.85	36.81	39.67	40.06	37.72	34.73
1550.0	0.14	0.19	6.09	6.24	43.31	33.70	37.61	39.61	37.05	33.37
1600.0	0.14	0.19	6.09	6.24	40.24	31.73	36.00	37.95	36.48	32.13
1650.0	0.15	0.21	6.11	6.28	37.53	30.20	35.27	38.40	36.91	31.64
1700.0	0.15	0.21	6.14	6.32	36.64	29.46	33.82	36.96	38.02	31.73
1750.0	0.15	0.21	6.19	6.37	35.43	28.67	32.62	36.29	40.07	32.55
1800.0	0.16	0.22	6.24	6.43	35.37	28.39	31.10	33.96	42.63	34.45
1850.0	0.16	0.22	6.29	6.48	34.98	28.59	29.70	32.47	39.72	37.47
1900.0	0.17	0.23	6.33	6.53	34.99	28.90	28.44	30.64	35.97	42.63
1950.0	0.18	0.23	6.37	6.56	34.98	29.30	27.25	29.42	32.95	40.95
2000.0	0.18	0.24	6.38	6.59	34.61	29.85	26.25	28.06	30.47	36.38
2100.0	0.20	0.25	6.37	6.58	32.55	30.72	25.09	26.76	27.55	31.33
2200.0	0.20	0.26	6.31	6.52	30.04	29.79	24.88	26.90	26.35	29.88
2300.0	0.21	0.27	6.24	6.45	28.21	29.01	25.35	28.69	25.79	29.62
2400.0	0.21	0.28	6.20	6.41	27.41	28.38	25.66	30.56	25.55	29.51
2500.0	0.22	0.29	6.22	6.43	27.65	28.10	25.20	30.28	25.70	29.08
2600.0	0.23	0.30	6.28	6.52	28.59	27.18	24.51	28.24	26.05	28.74
2700.0	0.24	0.31	6.39	6.64	29.36	25.92	24.36	27.96	27.29	29.33
2800.0	0.25	0.31	6.49	6.76	29.48	24.30	24.50	28.54	29.64	31.13
3000.0	0.25	0.32	6.56	6.85	29.77	24.27	24.06	27.42	30.62	43.64
3200.0	0.29	0.36	6.47	6.74	30.30	28.09	21.80	23.69	23.92	27.06
3400.0	0.31	0.39	6.42	6.68	23.42	22.04	21.14	24.60	21.82	24.01
3600.0	0.33	0.40	6.55	6.79	20.19	18.26	20.97	29.10	23.82	27.86
3800.0	0.43	0.43	6.87	7.06	22.22	19.07	16.10	18.38	19.53	24.28
4000.0	0.52	0.49	6.88	7.06	24.58	19.97	14.46	16.17	17.07	20.19

⁽¹⁾ Does not include coupling loss



DC PASS Bi-Directional Coupler

ZGBDC6-362HP+

Typical Performance Curves

Insertion Loss

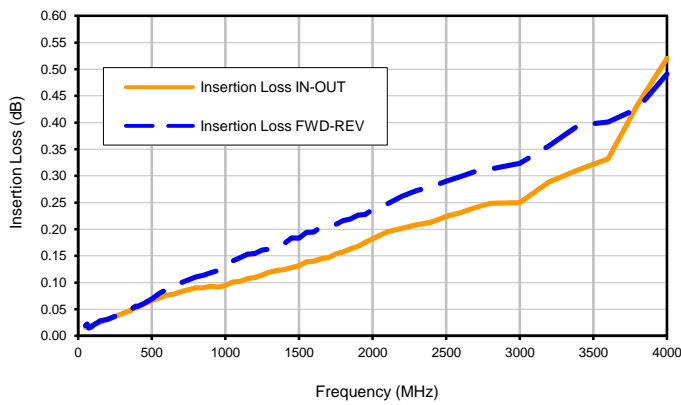

Coupling

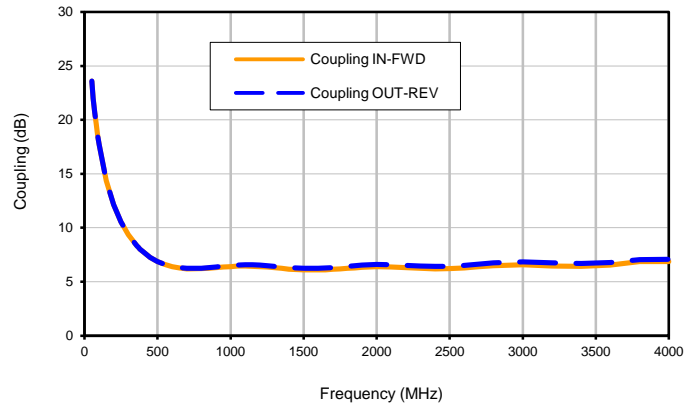

Directivity

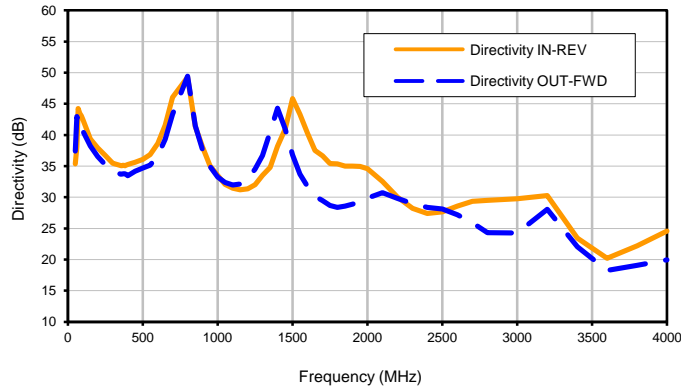

Return Loss

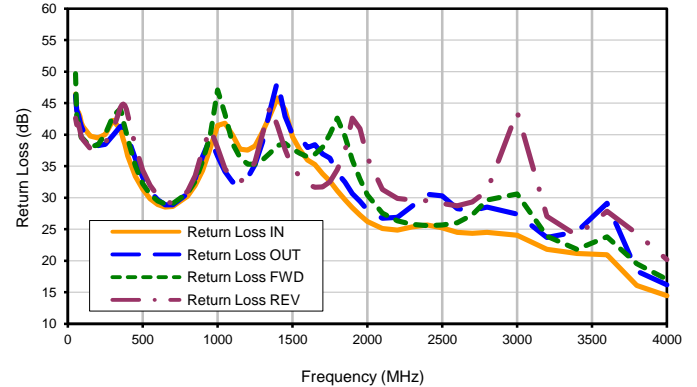

Outline Dimensions

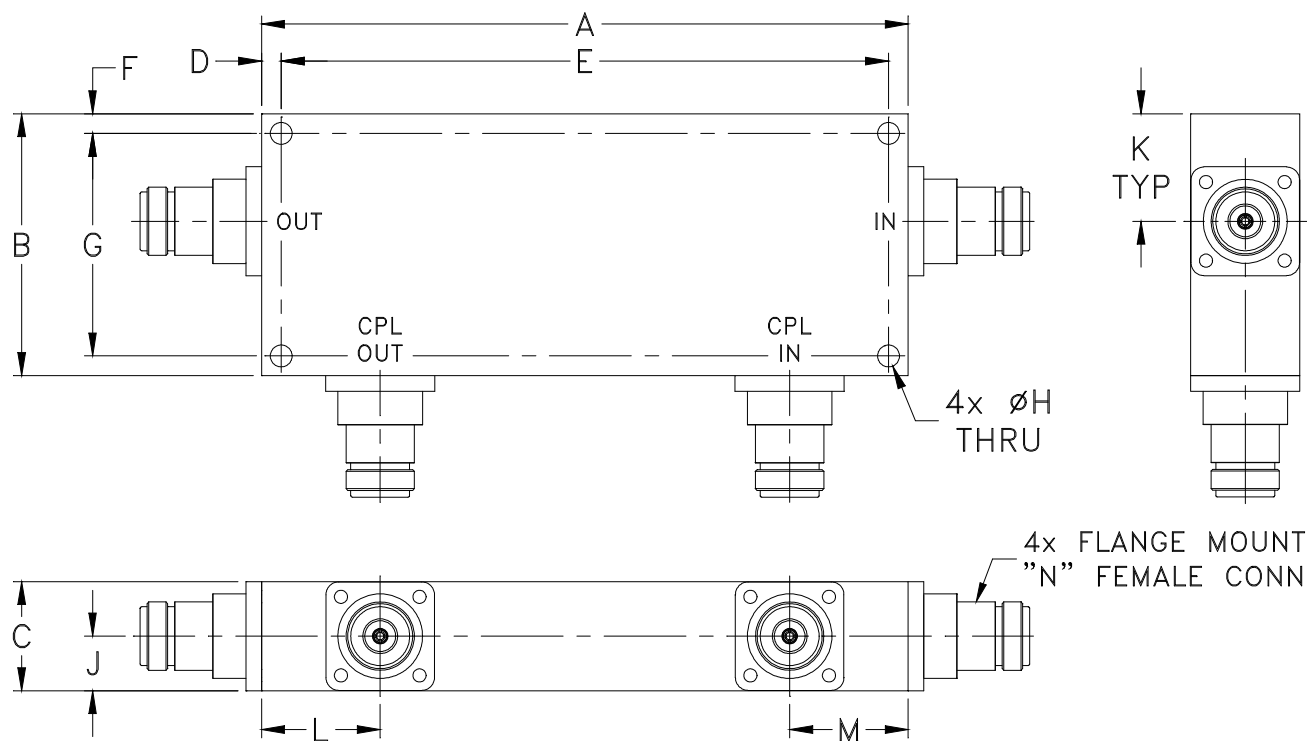

CASE #	A	B	C	D	E	F	G	H	J	K
HT1760	5.93 (150.62)	2.40 (60.96)	1.00 (25.40)	.18 (4.57)	5.565 (141.35)	.18 (4.57)	2.040 (51.82)	.200 (5.08)	.50 (12.70)	.99 (25.15)

CASE #	L	M	WT. GRAM
HT1760	1.09 (27.69)	1.09 (27.69)	700.0

Dimensions are in inches (mm). Tolerances: 2Pl. ± .03; 3Pl. ± .015

Notes:

1. Case material: Aluminum alloy.
2. Case finish:
For RoHS Case Styles: Clear chemical conversion coating, non-chrome or trivalent chrome based.

All Mini-Circuits products are manufactured under exacting quality assurance and control standards, and are capable of meeting published specifications after being subjected to any or all of the following physical and environmental test.

Specification	Test/Inspection Condition	Reference/Spec
Operating Temperature	-55° to 100° C Ambient Environment	Individual Model Data Sheet
Storage Temperature	-55° to 100° C Ambient Environment	Individual Model Data Sheet
Liquid Ingress	Immersion in 1 meter water, 1/2 hour	IP67, IEC60529
Thermal Shock	-55° to 100°C, 100 cycles	MIL-STD-202, Method 107, Condition A-3, except +100°C
Vibration (High Frequency)	20g peak, 10-2000 Hz, 12 times in each of three perpendicular directions (total 36)	MIL-STD-202, Method 204, Condition D
Mechanical Shock	100g, 6ms sawtooth, 3 shocks each direction 3 axes (total 18)	MIL-STD-202, Method 213, Condition I