

Coaxial Frequency Mixer

NON-CATALOG

ZP-10514+ ZP-10514

Level 7 (LO Power +7 dBm) 0.2 to 500 MHz



BNC version shown
CASE STYLE: GG60

Connectors	Model
BNC	ZP-10514+
SMB	ZP-10514-SMB(+)
SMA	ZP-10514-S(+)

+RoHS Compliant

The +Suffix identifies RoHS Compliance. See our web site for RoHS Compliance methodologies and qualifications

Maximum Ratings

Operating Temperature	-55°C to 100°C
Storage Temperature	-55°C to 100°C
RF Power	50mW
IF Current	40mA
Permanent damage may occur if any of these limits are exceeded.	

Coaxial Connections

LO	L
RF	R
IF	X

Outline Drawing

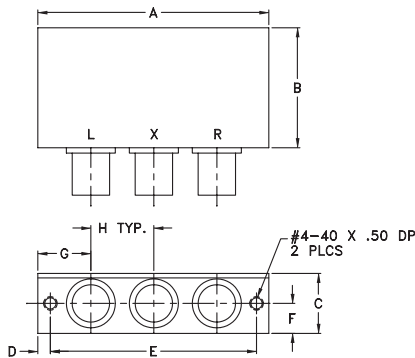

Outline Dimensions (inch/mm)

A	B	C	D	E	F	G	H	wt
2.31	1.20	.60	.125	2.062	.30	.53	.63	grams
58.67	30.48	15.24	3.18	52.37	7.62	13.46	16.00	75.0

Features

- low conversion loss, 5.18 dB typ.
- high L-R isolation, 50 dB typ.
- rugged shielded case

Applications

- VHF/UHF
- instrumentation

Electrical Specifications

FREQUENCY (MHz)		CONVERSION LOSS (dB)				LO-RF ISOLATION (dB)						LO-IF ISOLATION (dB)								
LO/RF	IF	Mid-Band		Total	L			M			U			L		M		U		
f_L-f_U		\bar{X}	σ	Max.	Range	Typ.	Min.	Typ.	Min.	Typ.	Min.	Typ.	Min.	Typ.	Min.	Typ.	Min.	Typ.	Min.	
0.2-500	DC-500	5.18	0.10	7.0	8.5	55	45	50	35	35	30	50	40	36	30	30	20			

1 dB COMP.: +1 dBm typ.

L = low range [f_L to $10 f_L$] M = mid range [$10 f_L$ to $f_U/2$] U = upper range [$f_U/2$ to f_U]
m = mid band [$2f_L$ to $f_U/2$]

Typical Performance Data

Frequency (MHz)		Conversion Loss (dB)	Isolation L-R (dB)	Isolation L-I (dB)	VSWR RF Port (:1)	VSWR LO Port (:1)
RF	LO	LO +7dBm	LO +7dBm	LO +7dBm	LO +7dBm	LO +7dBm
0.20	30.20	8.36	59.54	51.65	1.28	1.46
0.50	30.50	6.85	57.86	50.98	1.26	1.41
2.00	32.00	6.13	56.96	50.94	1.25	1.39
10.00	40.00	5.43	55.15	50.65	1.24	1.48
32.45	62.45	5.43	51.84	49.39	1.21	1.45
64.69	94.69	5.61	48.95	47.53	1.20	1.42
100.00	70.00	5.53	47.52	46.53	1.20	1.39
145.30	115.30	5.74	45.03	44.48	1.19	1.38
177.55	147.55	5.41	42.85	42.69	1.17	1.36
200.00	170.00	5.73	41.70	41.72	1.17	1.37
225.92	195.92	5.49	40.73	40.61	1.16	1.36
258.16	228.16	5.71	39.01	39.00	1.16	1.42
290.41	260.41	5.50	38.47	38.33	1.16	1.43
322.65	292.65	5.79	37.73	37.34	1.19	1.51
354.90	324.90	5.52	36.24	35.86	1.20	1.53
387.14	357.14	5.63	35.26	34.80	1.22	1.58
419.39	389.39	5.74	35.03	34.31	1.24	1.58
435.51	405.51	5.66	35.44	34.71	1.26	1.62
467.75	437.75	6.15	35.03	34.13	1.30	1.67
500.00	470.00	5.98	34.57	33.52	1.32	1.65

Electrical Schematic

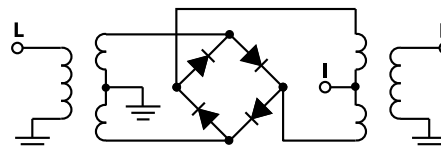

Notes

- Performance and quality attributes and conditions not expressly stated in this specification document are intended to be excluded and do not form a part of this specification document.
- Electrical specifications and performance data contained in this specification document are based on Mini-Circuit's applicable established test performance criteria and measurement instructions.
- The parts covered by this specification document are subject to Mini-Circuits standard limited warranty and terms and conditions (collectively, "Standard Terms"); Purchasers of this part are entitled to the rights and benefits contained therein. For a full statement of the Standard Terms and the exclusive rights and remedies thereunder, please visit Mini-Circuits' website at www.minicircuits.com/MCLStore/terms.jsp



Performance Charts

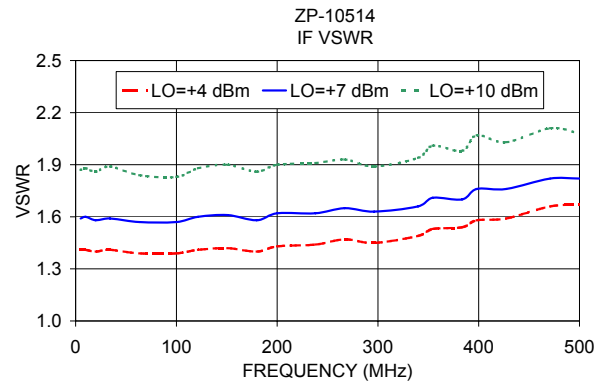
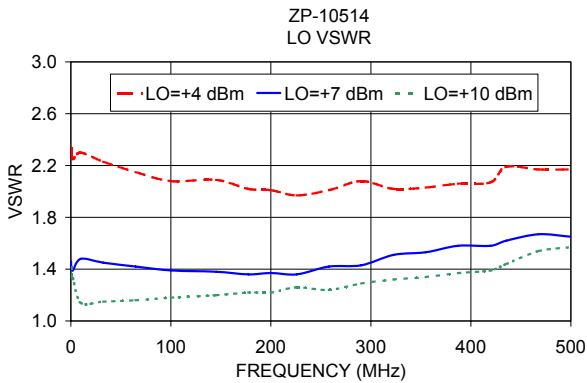
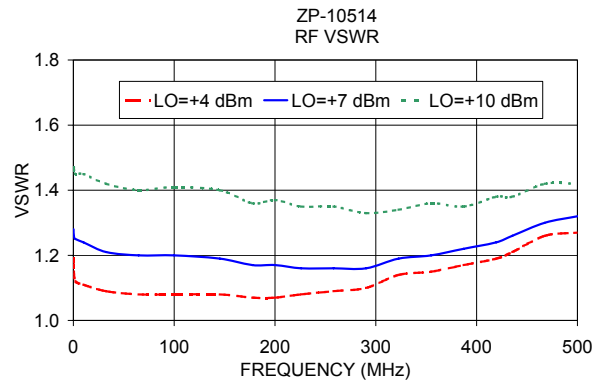
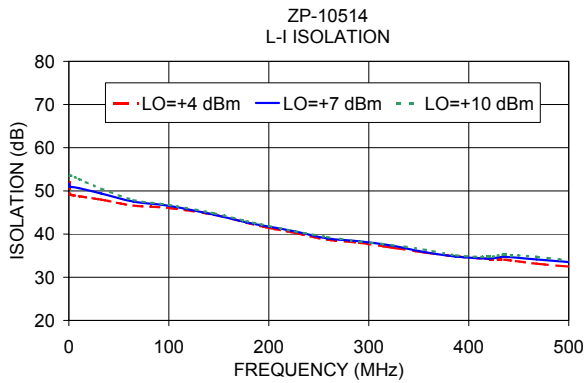
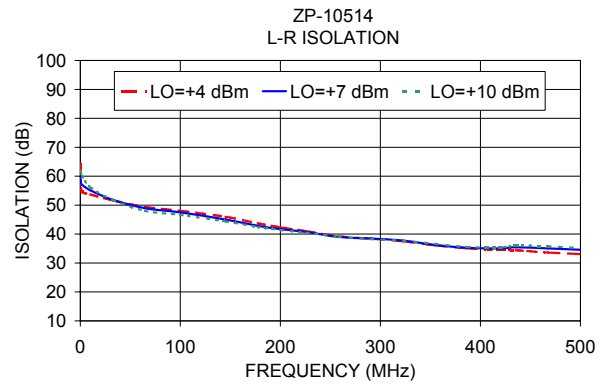
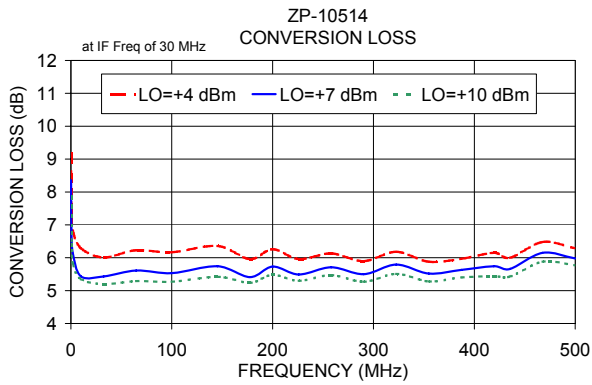

Notes

- A. Performance and quality attributes and conditions not expressly stated in this specification document are intended to be excluded and do not form a part of this specification document.
- B. Electrical specifications and performance data contained in this specification document are based on Mini-Circuit's applicable established test performance criteria and measurement instructions.
- C. The parts covered by this specification document are subject to Mini-Circuits standard limited warranty and terms and conditions (collectively, "Standard Terms"); Purchasers of this part are entitled to the rights and benefits contained therein. For a full statement of the Standard Terms and the exclusive rights and remedies thereunder, please visit Mini-Circuits' website at www.minicircuits.com/MCLStore/terms.jsp



Frequency Mixer

ZP-10514

Typical Performance Data

RF (IN) (MHz)	LO (MHz)	CONVERSION LOSS IF FIXED @IF(OUT)=30MHz (dB)			RF (IN) (MHz)	LO (MHz)	IP3 INPUT (dBm)			RF (IN) (MHz)	LO (MHz)	COMPRESSION @RF IN=+1dBm (dB)		
		@LO (dBm)					@LO (dBm)					@LO (dBm)		
		+4	+7	+10			+4	+7	+10			+4	+7	+10
10.1	40.1	5.42	5.00	4.63	10.1	40.1	17.37	19.06	21.15	10.1	40.1	0.56	0.14	0.12
30.1	60.1	5.78	5.24	5.03	30.1	60.1	17.44	20.69	21.48	30.1	60.1	0.19	0.10	0.04
50.1	80.1	5.90	5.39	5.12	50.1	80.1	14.48	16.70	17.72	50.1	80.1	0.13	0.03	0.02
70.1	100.1	5.64	5.24	5.05	70.1	100.1	20.26	20.27	21.48	70.1	100.1	0.28	0.15	0.07
90.1	120.1	5.73	5.33	5.10	90.1	120.1	15.70	16.93	19.77	90.1	120.1	0.29	0.08	0.06
110.1	140.1	5.94	5.44	5.20	110.1	140.1	15.24	18.80	19.09	110.1	140.1	0.17	0.06	0.02
130.1	160.1	5.98	5.50	5.29	130.1	160.1	15.11	18.74	18.86	130.1	160.1	0.19	0.07	0.03
150.1	180.1	5.95	5.53	5.33	150.1	180.1	15.39	17.92	17.70	150.1	180.1	0.20	0.05	0.02
170.1	200.1	5.79	5.46	5.27	170.1	200.1	17.83	16.73	16.38	170.1	200.1	0.29	0.14	0.07
190.1	220.1	6.02	5.63	5.42	190.1	220.1	14.63	17.81	17.17	190.1	220.1	0.22	0.08	0.05
210.1	240.1	6.01	5.61	5.39	210.1	240.1	17.17	16.73	18.34	210.1	240.1	0.22	0.08	0.05
230.1	260.1	6.05	5.67	5.48	230.1	260.1	16.09	15.21	15.40	230.1	260.1	0.24	0.09	0.04
250.1	280.1	6.02	5.65	5.46	250.1	280.1	15.49	14.63	15.14	250.1	280.1	0.27	0.12	0.07
270.1	300.1	6.10	5.72	5.52	270.1	300.1	14.74	15.20	15.79	270.1	300.1	0.26	0.13	0.09
290.1	320.1	6.27	5.83	5.55	290.1	320.1	14.63	15.04	16.99	290.1	320.1	0.19	0.10	0.06
310.1	340.1	6.29	5.86	5.55	310.1	340.1	13.25	14.63	18.25	310.1	340.1	0.15	0.07	0.05
330.1	360.1	6.40	6.03	5.73	330.1	360.1	13.53	13.67	15.91	330.1	360.1	0.18	0.06	0.05
350.1	380.1	6.34	6.01	5.76	350.1	380.1	14.27	14.09	15.63	350.1	380.1	0.32	0.16	0.09
370.1	400.1	6.44	6.09	5.87	370.1	400.1	15.94	15.29	16.15	370.1	400.1	0.32	0.13	0.08
390.1	420.1	6.47	6.07	5.81	390.1	420.1	17.19	16.17	17.42	390.1	420.1	0.31	0.12	0.08
410.1	440.1	6.44	6.05	5.81	410.1	440.1	17.11	16.38	17.90	410.1	440.1	0.35	0.16	0.11
440.1	470.1	6.46	6.02	5.79	440.1	470.1	14.95	18.39	20.83	440.1	470.1	0.48	0.24	0.12
460.1	490.1	6.71	6.24	5.99	460.1	490.1	11.06	17.36	21.00	460.1	490.1	0.42	0.24	0.12
490.1	520.1	6.91	6.39	6.08	490.1	520.1	7.10	12.11	19.04	490.1	520.1	0.46	0.28	0.13
510.1	540.1	7.16	6.65	6.28	510.1	540.1	5.01	7.95	13.89	510.1	540.1	0.41	0.25	0.14
540.1	570.1	7.34	6.84	6.42	540.1	570.1	4.31	5.57	9.48	540.1	570.1	0.51	0.33	0.20
560.1	590.1	7.67	7.12	6.65	560.1	590.1	4.10	4.99	7.83	560.1	590.1	0.36	0.21	0.15
590.1	620.1	7.98	7.39	6.88	590.1	620.1	4.49	5.17	6.80	590.1	620.1	0.32	0.19	0.15
610.1	640.1	8.28	7.66	7.13	610.1	640.1	5.01	5.82	7.24	610.1	640.1	0.19	0.11	0.10
640.1	670.1	8.74	7.98	7.32	640.1	670.1	6.12	7.90	10.15	640.1	670.1	-0.03	-0.02	0.06
660.1	690.1	9.00	8.14	7.40	660.1	690.1	6.90	9.07	12.22	660.1	690.1	-0.19	-0.10	0.04
690.1	720.1	9.20	8.12	7.28	690.1	720.1	7.16	9.45	13.75	690.1	720.1	-0.20	0.01	0.18
710.1	740.1	9.25	8.05	7.25	710.1	740.1	7.47	10.38	15.31	710.1	740.1	-0.14	0.10	0.25
740.1	770.1	9.45	8.15	7.42	740.1	770.1	8.09	12.07	16.12	740.1	770.1	-0.12	0.15	0.22
760.1	790.1	9.39	8.16	7.52	760.1	790.1	9.27	13.17	16.85	760.1	790.1	0.04	0.23	0.26
790.1	820.1	9.54	8.46	7.87	790.1	820.1	10.67	13.65	15.59	790.1	820.1	0.18	0.23	0.21
810.1	840.1	9.71	8.69	8.15	810.1	840.1	11.76	14.21	15.37	810.1	840.1	0.24	0.23	0.20
840.1	870.1	10.20	9.29	8.79	840.1	870.1	11.95	14.16	15.14	840.1	870.1	0.19	0.18	0.16
860.1	890.1	10.43	9.60	9.10	860.1	890.1	12.01	14.12	15.81	860.1	890.1	0.23	0.20	0.18
890.1	920.1	10.99	10.31	9.86	890.1	920.1	12.00	13.99	16.58	890.1	920.1	0.13	0.14	0.15



Frequency Mixer

ZP-10514

Typical Performance Data

IF (OUT) (MHz)	LO (MHz)	CONVERSION LOSS VS. IF FREQUENCY @RF(IN)=250.1MHz (dB)	IF (OUT) (MHz)	LO (MHz)	CONVERSION LOSS VS. IF FREQUENCY @RF(IN)=10.1MHz (dB)	IF (OUT) (MHz)	LO (MHz)	CONVERSION LOSS VS. IF FREQUENCY @RF(IN)=500.1MHz (dB)
		@LO (dBm)			@LO (dBm)			@LO (dBm)
		+7			+7			+7
240.0	10.1	5.58	10.0	20.1	5.23	490.0	10.1	6.31
234.1	16.0	5.66	50.0	60.1	4.91	477.7	22.4	6.21
228.2	21.9	5.64	90.0	100.1	5.12	465.4	34.7	6.16
222.3	27.8	5.60	130.0	140.1	5.03	453.1	47.0	6.19
216.4	33.7	5.55	170.0	180.1	5.24	440.8	59.3	6.18
210.5	39.6	5.50	210.0	220.1	5.24	428.5	71.6	6.12
204.6	45.5	5.55	250.0	260.1	5.11	416.2	83.9	6.06
198.7	51.4	5.42	290.0	300.1	5.25	403.8	96.3	6.07
192.8	57.3	5.39	330.0	340.1	5.31	391.5	108.6	6.03
186.9	63.2	5.47	370.0	380.1	5.36	379.2	120.9	6.05
181.0	69.1	5.46	410.0	420.1	5.17	366.9	133.2	5.97
175.1	75.0	5.41	430.0	440.1	5.13	354.6	145.5	6.06
169.2	80.9	5.41	470.0	480.1	5.12	342.3	157.8	6.01
163.3	86.8	5.40	490.0	500.1	5.35	330.0	170.1	6.06
157.4	92.7	5.39	530.0	540.1	5.40	317.7	182.4	5.98
151.5	98.6	5.31	550.0	560.1	5.09	305.4	194.7	6.06
145.6	104.5	5.31	590.0	600.1	5.40	293.1	207.0	6.02
139.7	110.4	5.38	610.0	620.1	5.27	280.8	219.3	6.08
133.8	116.3	5.41	650.0	660.1	5.31	268.5	231.6	6.05
127.9	122.2	5.36	670.0	680.1	5.14	256.2	243.9	6.12
122.1	128.0	5.35	710.0	720.1	5.25	243.8	256.3	6.09
116.2	133.9	5.38	730.0	740.1	5.19	231.5	268.6	6.02
110.3	139.8	5.35	770.0	780.1	5.14	219.2	280.9	6.07
104.4	145.7	5.30	790.0	800.1	5.19	206.9	293.2	6.17
98.5	151.6	5.33	830.0	840.1	5.08	194.6	305.5	6.26
92.6	157.5	5.42	850.0	860.1	4.95	182.3	317.8	6.17
86.7	163.4	5.42	890.0	900.1	5.13	170.0	330.1	6.22
80.8	169.3	5.38	910.0	920.1	5.05	157.7	342.4	6.08
74.9	175.2	5.43	950.0	960.1	5.34	145.4	354.7	6.28
69.0	181.1	5.47	970.0	980.1	5.66	133.1	367.0	6.22
63.1	187.0	5.42	1010.0	1020.1	5.81	120.8	379.3	6.27
57.2	192.9	5.41	1030.0	1040.1	5.92	108.5	391.6	6.23
51.3	198.8	5.45	1070.0	1080.1	6.30	96.2	403.9	6.32
45.4	204.7	5.52	1090.0	1100.1	6.94	83.8	416.3	6.31
39.5	210.6	5.50	1130.0	1140.1	7.28	71.5	428.6	6.28
33.6	216.5	5.50	1150.0	1160.1	7.78	59.2	440.9	6.32
27.7	222.4	5.53	1190.0	1200.1	8.56	46.9	453.2	6.26
21.8	228.3	5.58	1210.0	1220.1	8.65	34.6	465.5	6.30
15.9	234.2	5.51	1250.0	1260.1	9.96	22.3	477.8	6.27
10.0	240.1	5.49	1270.0	1280.1	10.43	10.0	490.1	6.31

Frequency Mixer

ZP-10514

Typical Performance Data

LO (MHz)	LO-RF ISOLATION (dB)			LO-IF ISOLATION (dB)			RF (IN) (MHz)	LO (MHz)	RF-IF ISOLATION (dB)		
	@LO (dBm)			@LO (dBm)					@LO (dBm)		
	+4	+7	+10	+4	+7	+10			+4	+7	+10
40.1	59.59	59.52	60.41	64.26	62.48	59.91	10.1	40.1	42.61	42.49	42.14
60.1	57.77	57.46	57.40	61.57	60.15	57.81	30.1	60.1	34.60	34.60	34.62
80.1	55.41	55.62	55.52	60.51	59.44	56.91	50.1	80.1	30.65	30.78	30.87
100.1	53.86	54.16	54.06	57.72	57.58	55.41	70.1	100.1	28.18	28.36	28.46
120.1	52.44	52.83	52.83	54.57	55.16	53.94	90.1	120.1	26.34	26.58	26.67
140.1	51.55	51.78	51.51	51.73	52.34	51.36	110.1	140.1	25.29	25.54	25.72
160.1	50.76	51.03	50.92	49.24	50.32	50.27	130.1	160.1	24.33	24.68	24.89
180.1	49.86	50.01	49.80	47.04	48.67	49.29	150.1	180.1	23.66	23.97	24.19
200.1	49.39	49.26	48.89	44.89	46.68	47.30	170.1	200.1	23.27	23.53	23.66
220.1	48.72	48.88	48.59	43.20	45.22	46.71	190.1	220.1	22.93	23.37	23.58
240.1	48.20	48.62	48.34	42.07	44.42	46.00	210.1	240.1	22.46	23.13	23.54
260.1	47.16	47.41	47.41	41.04	42.90	43.97	230.1	260.1	22.17	22.82	23.33
280.1	46.13	46.04	45.89	39.82	41.65	42.73	250.1	280.1	22.22	22.90	23.49
300.1	45.38	44.95	44.80	38.80	40.34	41.72	270.1	300.1	22.58	23.05	23.52
320.1	45.17	44.50	44.20	38.07	39.63	41.08	290.1	320.1	23.50	23.92	24.29
340.1	45.51	44.99	44.61	37.71	39.40	40.62	310.1	340.1	24.33	24.71	24.99
360.1	45.51	45.16	44.78	36.84	38.88	40.04	330.1	360.1	25.41	25.90	26.23
380.1	45.57	45.10	44.67	35.75	38.35	40.06	350.1	380.1	25.53	26.26	26.78
400.1	47.12	46.04	45.22	35.33	37.99	40.05	370.1	400.1	24.72	25.63	26.47
420.1	46.97	45.45	44.24	34.60	37.15	39.21	390.1	420.1	22.90	23.73	24.55
440.1	46.35	45.05	44.06	33.85	36.14	38.39	410.1	440.1	21.35	21.90	22.45
470.1	44.46	44.00	43.15	32.80	34.75	36.57	440.1	470.1	19.16	19.20	19.30
490.1	43.10	43.20	42.79	32.38	34.09	35.69	460.1	490.1	18.23	18.01	17.91
520.1	40.74	41.06	41.01	32.12	33.05	34.53	490.1	520.1	17.17	16.74	16.50
540.1	39.75	40.06	40.30	32.21	32.70	34.02	510.1	540.1	16.59	16.22	15.98
570.1	38.98	39.11	39.39	32.58	32.83	33.57	540.1	570.1	16.01	15.45	15.21
590.1	38.37	38.35	38.56	32.74	32.88	33.26	560.1	590.1	15.56	15.23	14.80
620.1	38.18	38.10	38.25	32.91	33.62	33.71	590.1	620.1	15.08	14.81	14.47
640.1	38.06	37.98	37.94	32.82	33.99	34.21	610.1	640.1	14.98	14.66	14.45
670.1	37.94	38.08	38.27	32.20	33.77	34.57	640.1	670.1	14.81	14.48	14.27
690.1	37.66	37.71	37.64	31.43	32.85	33.82	660.1	690.1	14.66	14.48	14.14
720.1	37.06	37.26	37.44	30.10	30.79	31.32	690.1	720.1	14.38	14.20	14.07
740.1	36.38	36.38	36.37	29.23	29.31	29.46	710.1	740.1	14.18	14.08	14.00
770.1	35.72	35.63	35.69	28.18	27.60	27.58	740.1	770.1	13.90	13.88	13.98
790.1	34.94	34.70	34.60	27.72	26.99	26.91	760.1	790.1	13.65	13.65	13.65
820.1	34.44	34.08	33.85	27.18	26.41	26.17	790.1	820.1	13.03	13.11	13.07
840.1	34.02	33.55	33.23	27.06	26.21	25.78	810.1	840.1	12.76	12.79	12.81
870.1	33.82	33.02	32.60	26.96	25.79	25.17	840.1	870.1	12.22	12.11	12.09
890.1	33.50	32.69	32.11	26.91	25.69	24.84	860.1	890.1	11.82	11.72	11.64
920.1	32.85	31.85	31.01	26.63	25.24	24.13	890.1	920.1	11.26	11.05	10.88

Frequency Mixer

ZP-10514

Typical Performance Data

RF (IN) (MHz)	LO (MHz)	RF VSWR (:1)		
		@LO (dBm)		
		+4	+7	+10
10.1	40.1	1.33	1.27	1.08
30.1	60.1	1.41	1.24	1.15
50.1	80.1	1.42	1.25	1.12
70.1	100.1	1.35	1.19	1.08
90.1	120.1	1.37	1.20	1.11
110.1	140.1	1.37	1.17	1.08
130.1	160.1	1.32	1.16	1.07
150.1	180.1	1.30	1.14	1.06
170.1	200.1	1.29	1.14	1.05
190.1	220.1	1.29	1.13	1.05
210.1	240.1	1.22	1.07	1.01
230.1	260.1	1.20	1.07	1.02
250.1	280.1	1.18	1.06	1.03
270.1	300.1	1.18	1.05	1.03
290.1	320.1	1.16	1.04	1.06
310.1	340.1	1.13	1.06	1.10
330.1	360.1	1.14	1.09	1.12
350.1	380.1	1.14	1.11	1.14
370.1	400.1	1.14	1.13	1.17
390.1	420.1	1.14	1.17	1.23
410.1	440.1	1.17	1.23	1.29
440.1	470.1	1.18	1.26	1.32
460.1	490.1	1.17	1.25	1.31
490.1	520.1	1.19	1.23	1.29
510.1	540.1	1.21	1.21	1.26
540.1	570.1	1.26	1.22	1.24
560.1	590.1	1.32	1.27	1.27
590.1	620.1	1.48	1.41	1.39
610.1	640.1	1.61	1.54	1.50
640.1	670.1	1.82	1.73	1.69
660.1	690.1	1.97	1.87	1.81
690.1	720.1	2.22	2.10	2.03
710.1	740.1	2.34	2.21	2.13
740.1	770.1	2.49	2.35	2.27
760.1	790.1	2.57	2.44	2.36
790.1	820.1	2.72	2.60	2.52
810.1	840.1	2.75	2.65	2.57
840.1	870.1	2.82	2.72	2.65
860.1	890.1	2.86	2.77	2.70
890.1	920.1	2.90	2.82	2.75

LO (MHz)	LO VSWR (:1)		
	@LO (dBm)		
	+4	+7	+10
40.1	1.07	1.82	2.86
60.1	1.08	1.74	2.63
80.1	1.08	1.69	2.48
100.1	1.08	1.75	2.62
120.1	1.08	1.66	2.40
140.1	1.13	1.81	2.72
160.1	1.12	1.71	2.48
180.1	1.11	1.73	2.53
200.1	1.16	1.76	2.56
220.1	1.17	1.72	2.46
240.1	1.20	1.86	2.72
260.1	1.21	1.75	2.48
280.1	1.25	1.84	2.64
300.1	1.29	1.83	2.56
320.1	1.30	1.85	2.60
340.1	1.35	1.95	2.75
360.1	1.36	1.89	2.62
380.1	1.40	1.96	2.73
400.1	1.41	1.91	2.61
420.1	1.44	1.97	2.74
440.1	1.53	2.05	2.80
470.1	1.56	2.02	2.73
490.1	1.64	2.10	2.79
520.1	1.70	2.20	2.92
540.1	1.72	2.21	2.92
570.1	1.76	2.27	3.00
590.1	1.78	2.30	3.05
620.1	1.80	2.29	3.01
640.1	1.81	2.26	2.97
670.1	1.82	2.26	2.96
690.1	1.82	2.24	2.92
720.1	1.82	2.17	2.82
740.1	1.82	2.15	2.80
770.1	1.84	2.16	2.82
790.1	1.87	2.17	2.82
820.1	1.95	2.21	2.82
840.1	2.03	2.26	2.84
870.1	2.16	2.34	2.89
890.1	2.26	2.40	2.91
920.1	2.42	2.47	2.93

IF (OUT) (MHz)	IF VSWR @LO=500.1MHz (:1)		
	@LO (dBm)		
	+4	+7	+10
10.1	2.27	1.83	1.56
20.1	2.39	1.91	1.63
30.1	2.39	1.92	1.64
40.1	2.33	1.88	1.60
50.1	2.33	1.87	1.60
60.1	2.37	1.90	1.63
70.1	2.37	1.91	1.64
80.1	2.29	1.86	1.60
90.1	2.20	1.79	1.54
100.1	2.23	1.81	1.55
110.1	2.33	1.88	1.61
120.1	2.35	1.92	1.65
130.1	2.29	1.87	1.62
140.1	2.22	1.81	1.58
150.1	2.23	1.82	1.58
160.1	2.27	1.86	1.61
170.1	2.22	1.83	1.60
180.1	2.14	1.77	1.55
190.1	2.15	1.77	1.55
200.1	2.22	1.83	1.60
210.1	2.24	1.86	1.63
220.1	2.17	1.82	1.61
240.1	2.14	1.78	1.58
250.1	2.18	1.83	1.63
270.1	2.04	1.73	1.56
280.1	2.02	1.70	1.53
300.1	2.12	1.81	1.63
310.1	2.08	1.78	1.63
330.1	2.03	1.74	1.59
340.1	2.07	1.78	1.63
360.1	1.97	1.72	1.60
370.1	1.92	1.66	1.54
390.1	2.02	1.75	1.62
400.1	2.00	1.75	1.64
420.1	1.92	1.67	1.58
430.1	1.97	1.71	1.61
450.1	1.91	1.70	1.63
460.1	1.85	1.63	1.56
480.1	1.95	1.70	1.61
490.1	1.96	1.73	1.66

REV. X2
ZP-10514
101011
Page 4 of 5



IF/RF MICROWAVE COMPONENTS • ISO 9001 ISO 14001 AS 9100 CERTIFIED RoHS compliant
P.O. Box 350166, Brooklyn, New York 11235-0006 (718) 934-4500 Fax (718) 332-4661



The Design Engineers Search Engine finds the model you need, instantly • For detailed performance specs & shopping online see



Harmonics Tables

RF HARMONICS ORDER

	(-dBm)	(-dBc)										
0	-	-	14	24	19	31	18	46	25	43	46	44
1	-	17	+0	25	13	36	25	39	36	41	39	41
2	82	>69	67	>69	62	>69	66	69	57	>69	60	>69
3	>90	>69	66	>69	63	>69	59	>69	58	>69	68	>69
4	>90	>69	>69	>69	>69	>69	>69	>69	>69	>69	>69	>69
5	>90	>69	>69	>69	>69	>69	>69	>69	>69	>69	>69	>69
6	>90	>69	>69	>69	>69	>69	>69	>69	>69	>69	>69	>69
7	>90	>69	>69	>69	>69	>69	>69	>69	>69	>69	>69	>69
8	>90	>69	>69	>69	>69	>69	>69	>69	>69	>69	>69	>69
9	>90	>69	>69	>69	>69	>69	>69	>69	>69	>69	>69	>69
10	>90	>69	>69	>69	>69	>69	>69	>69	>69	>69	>69	>69
	RF CAL	0	1	2	3	4	5	6	7	8	9	10

LO HARMONICS ORDER

Test conditions: RF IN: 250.1 MHz; -14.00 dBm.
 LO IN: 280.1 MHz; +7.00 dBm
 IF OUT: 30 MHz; -19.69 dBm

RF HARMONICS ORDER

	(-dBm)	(-dBc)										
0	-	-	25	34	30	44	31	59	41	61	57	60
1	-	17	+0	26	13	35	23	41	41	44	44	43
2	62	68	57	66	53	66	58	63	50	66	52	>79
3	>90	52	44	50	46	57	42	52	46	60	53	61
4	>90	>79	77	>79	78	78	72	75	78	>79	71	77
5	>90	73	68	75	62	75	58	71	56	74	58	77
6	>90	>79	>79	>79	>79	>79	>79	>79	>79	>79	>79	>79
7	>90	>79	>79	>79	79	>79	75	>79	74	>79	72	>79
8	>90	>79	>79	>79	>79	>79	>79	>79	>79	>79	>79	>79
9	>90	>79	>79	>79	>79	>79	>79	>79	>79	>79	>79	>79
10	>90	>79	>79	>79	>79	>79	>79	>79	>79	>79	>79	>79
	RF CAL	0	1	2	3	4	5	6	7	8	9	10

LO HARMONICS ORDER

Test conditions: RF IN: 250.1 MHz; -4.00 dBm.
 LO IN: 280.1 MHz; +7.00 dBm
 IF OUT: 30 MHz; -9.62 dBm

- Notes: 1. All Harmonics are in (dBc) relative to IF OUTPUT.
 2. + entry denotes harmonics are in (dBc) above IF OUTPUT.
 3. RF Cal represent the Harmonics level of the RF input signal to the mixer.

Typical Performance Curves

Conversion Loss @ IF=30MHz

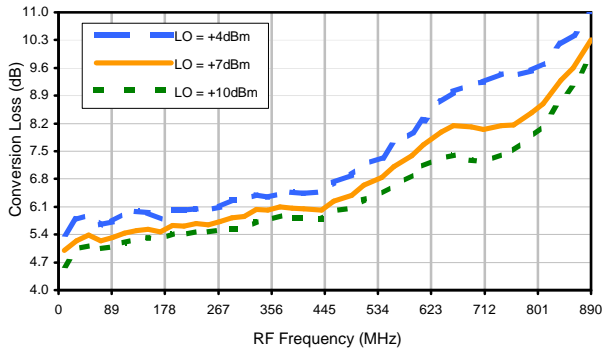

Conversion Loss vs. IF @ RF=250.1MHz

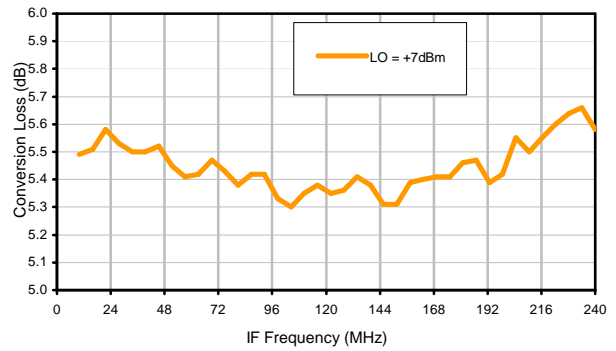

Conversion Loss vs. IF @ RF=10.1MHz

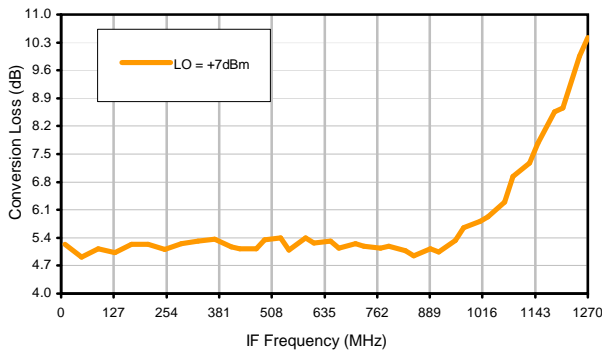

Conversion Loss vs. IF @ RF=500.1MHz

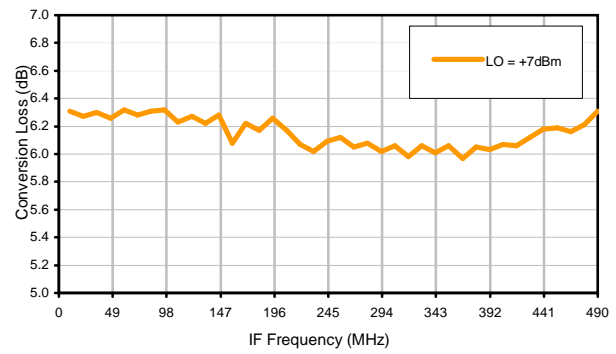

IP3 Input

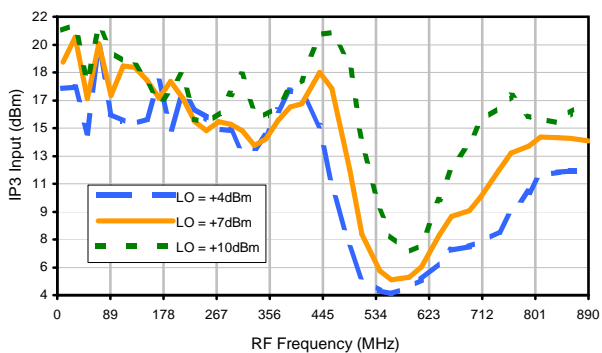

Compression @ RF IN=+1dBm

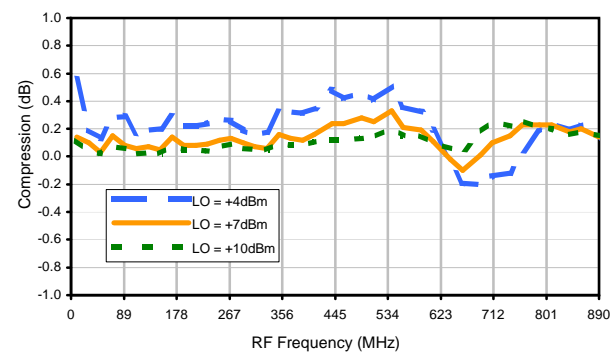

Typical Performance Curves

LO-RF Isolation

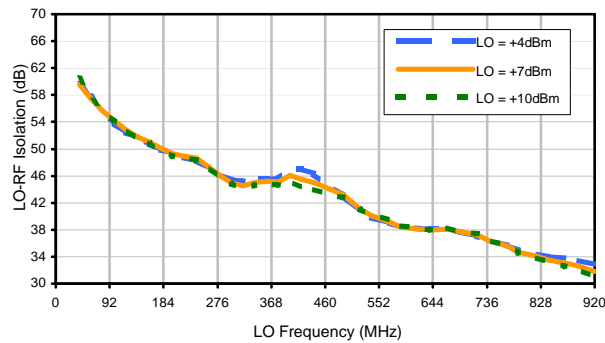

LO-IF Isolation

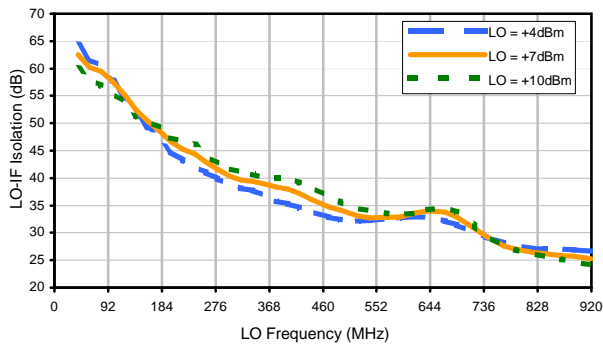

RF-IF Isolation

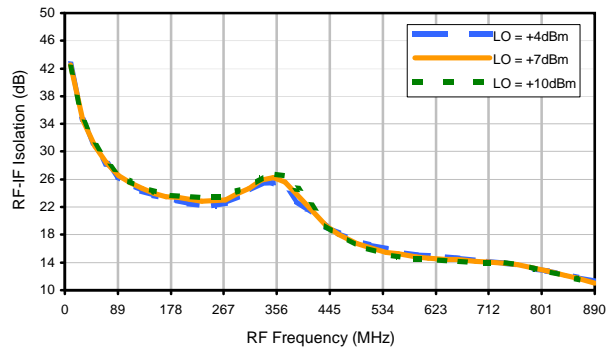

RF VSWR

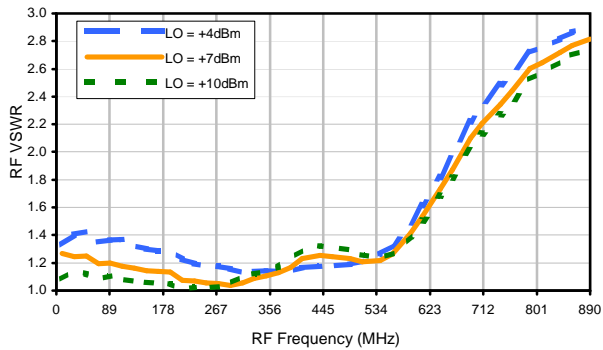

LO VSWR

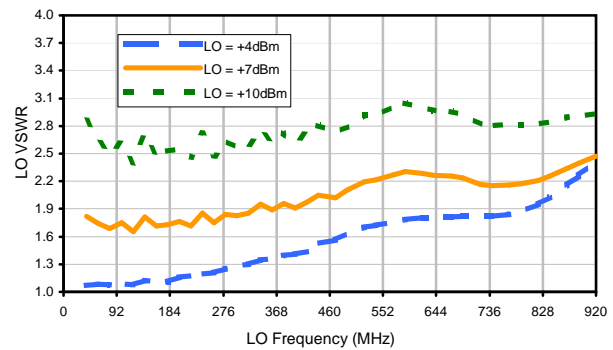

IF VSWR

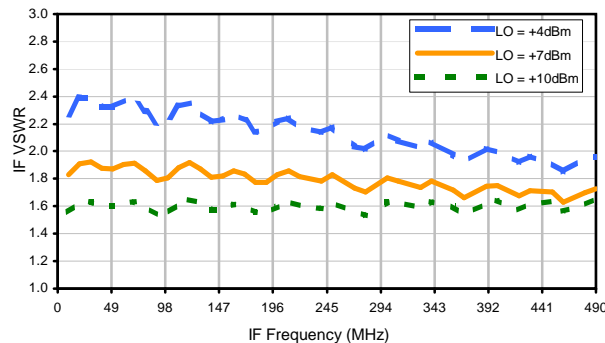

Harmonics Tables

RF HARMONICS ORDER

	(-dBm)	(-dBc)										
0	-	-	14	24	19	31	18	46	25	43	46	44
1	-	17	+0	25	13	36	25	39	36	41	39	41
2	82	>69	67	>69	62	>69	66	69	57	>69	60	>69
3	>90	>69	66	>69	63	>69	59	>69	58	>69	68	>69
4	>90	>69	>69	>69	>69	>69	>69	>69	>69	>69	>69	>69
5	>90	>69	>69	>69	>69	>69	>69	>69	>69	>69	>69	>69
6	>90	>69	>69	>69	>69	>69	>69	>69	>69	>69	>69	>69
7	>90	>69	>69	>69	>69	>69	>69	>69	>69	>69	>69	>69
8	>90	>69	>69	>69	>69	>69	>69	>69	>69	>69	>69	>69
9	>90	>69	>69	>69	>69	>69	>69	>69	>69	>69	>69	>69
10	>90	>69	>69	>69	>69	>69	>69	>69	>69	>69	>69	>69
	RF CAL	0	1	2	3	4	5	6	7	8	9	10

LO HARMONICS ORDER

Test conditions: RF IN: 250.1 MHz; -14.00 dBm.
 LO IN: 280.1 MHz; +7.00 dBm
 IF OUT: 30 MHz; -19.69 dBm

RF HARMONICS ORDER

	(-dBm)	(-dBc)										
0	-	-	25	34	30	44	31	59	41	61	57	60
1	-	17	+0	26	13	35	23	41	41	44	44	43
2	62	68	57	66	53	66	58	63	50	66	52	>79
3	>90	52	44	50	46	57	42	52	46	60	53	61
4	>90	>79	77	>79	78	78	72	75	78	>79	71	77
5	>90	73	68	75	62	75	58	71	56	74	58	77
6	>90	>79	>79	>79	>79	>79	>79	>79	>79	>79	>79	>79
7	>90	>79	>79	>79	79	>79	75	>79	74	>79	72	>79
8	>90	>79	>79	>79	>79	>79	>79	>79	>79	>79	>79	>79
9	>90	>79	>79	>79	>79	>79	>79	>79	>79	>79	>79	>79
10	>90	>79	>79	>79	>79	>79	>79	>79	>79	>79	>79	>79
	RF CAL	0	1	2	3	4	5	6	7	8	9	10

LO HARMONICS ORDER

Test conditions: RF IN: 250.1 MHz; -4.00 dBm.
 LO IN: 280.1 MHz; +7.00 dBm
 IF OUT: 30 MHz; -9.62 dBm

- Notes: 1. All Harmonics are in (dBc) relative to IF OUTPUT.
 2. + entry denotes harmonics are in (dBc) above IF OUTPUT.
 3. RF Cal represent the Harmonics level of the RF input signal to the mixer.

Outline Dimensions

GG60

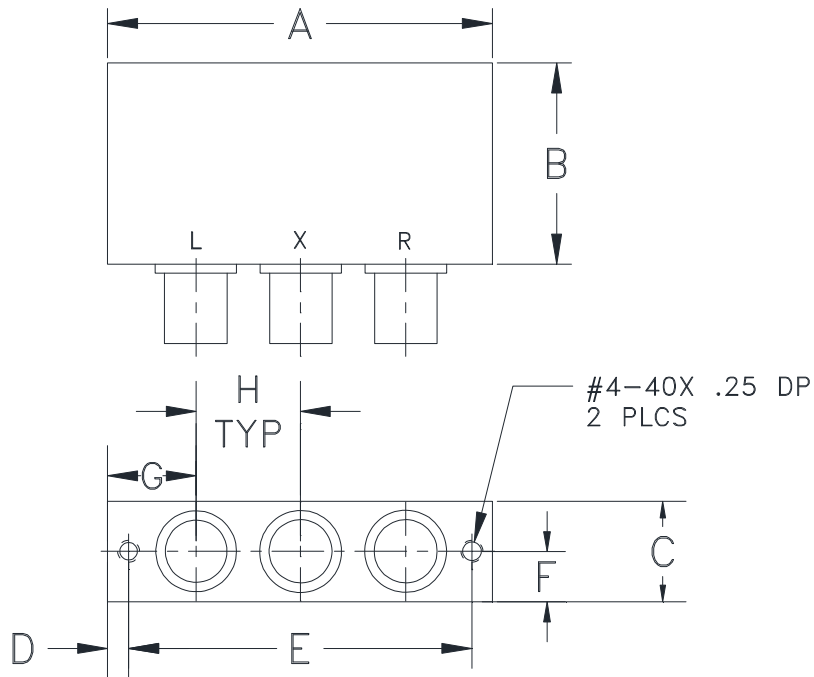

CASE #.	A	B	C	D	E	F	G	H	WT. GRAM
GG60	2.31 (58.67)	1.20 (30.48)	.60 (15.24)	.125 (3.18)	2.062 (52.37)	.30 (7.62)	.53 (13.46)	.63 (16.00)	75.0

Dimensions are in inches (mm). Tolerances: 2Pl. $\pm .03$; 3Pl. $\pm .015$

Notes:

- Case material: Aluminum alloy.
- Case finish:
For RoHS Case Styles: Clear chemical conversion coating, non-chrome or trivalent chrome based.



All Mini-Circuits products are manufactured under exacting quality assurance and control standards, and are capable of meeting published specifications after being subjected to any or all of the following physical and environmental test.

Specification	Test/Inspection Condition	Reference/Spec
Operating Temperature	-55° to 100°C Ambient Environment	Individual Model Data Sheet
Storage Temperature	-55° to 100° C Ambient Environment	Individual Model Data Sheet
Barometric Pressure	100,000 Feet	MIL-STD-202, Method 105, Condition D
Humidity	90% RH, 65°C Units may require bake-out after humidity to restore full performance.	MIL-STD-202, Method 103
Thermal Shock	-65° to 125°C, 5 cycles	MIL-STD-202, Method 107, Condition B
Vibration (High Frequency)	20g peak, 10-2000 Hz, 12 times in each of three perpendicular directions (total 36)	MIL-STD-202, Method 204, Condition D
Mechanical Shock	100g, 6ms sawtooth, 3 shocks each direction 3 axes (total 18)	MIL-STD-202, Method 213, Condition I