



COAXIAL

# Low Noise Amplifier ZQL-2G22G70W3+

50Ω 2200 to 2700 MHz 0.5 W SMA-Female

## KEY FEATURES

- Very Low Noise Figure, 1.1 dB typ.
- High OIP3, +36 dBm typ.
- Rugged, shielded case



Generic photo used for illustration purposes only

## APPLICATIONS

- Communication Systems
- R&D, Production, and OTA Test Systems
- Test & Measurement Equipment
- General Laboratory Applications

## FUNCTIONAL DIAGRAM

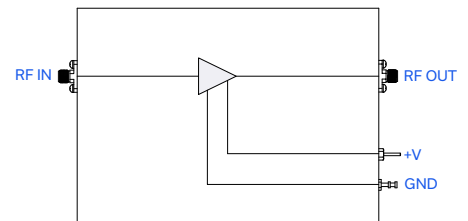

## PRODUCT OVERVIEW

The ZQL-2G22G70W3+ is a low-noise amplifier providing about 0.5 W of output power with a typical small signal gain of 34 dB over the 2200 to 2700 MHz frequency band. The amplifier uses state-of-the-art semiconductor technology and can be used in various applications. A single supply voltage ensures ease of operation. The amplifier is made with a rugged aluminum housing.

## ELECTRICAL SPECIFICATIONS AT $T_{\text{MOUNTINGBASE}} = +25^{\circ}\text{C}$ , $V_{\text{DC}} = +15\text{ V}$

Parameter	Symbol	Condition	Min.	Typ.	Max.	Units
Frequency Range	f		2200		2700	MHz
Small Signal Gain	$G_{\text{SS}}$	$P_{\text{OUT}} = -25\text{ dBm}$	29	34	36	dB
Small Signal Gain Flatness	$G_{\text{SS-FLAT}}$	$P_{\text{OUT}} = -25\text{ dBm}$		$\pm 1.0$	$\pm 1.5$	dB
Output Power at 1dB compression	$P_{1\text{dB}}$		+22.5	+25.5		dBm
Noise Figure	NF			1.1	1.5	dB
Output Third Order Intercept Point	OIP3	$P_{\text{OUT}} = +10\text{ dBm/tone}$ , $\text{df}=1\text{MHz}$	+34	+36		dBm
VSWR	I-VSWR	$P_{\text{OUT}} = -25\text{ dBm}$		1.3:1	1.5:1	-
VSWR	O-VSWR	$P_{\text{OUT}} = -25\text{ dBm}$		1.3:1	1.5:1	-
DC Supply Voltage	$V_{\text{DC}}$		+13	+15	+17	V
Supply Current	$I_{\text{DC}}$			192	340	mA

REV. OR  
ECO-022053  
ZQL-2G22G70W3+  
MCL NY  
240611





COAXIAL

# Low Noise Amplifier **ZQL-2G22G70W3+**

Mini-Circuits

50Ω 2200 to 2700 MHz 0.5 W SMA-Female

TYPICAL PERFORMANCE DATA AT  $T_{\text{MOUNTINGBASE}} = +25^{\circ}\text{C}$ ,  $V_{\text{DC}} = +15\text{ V}$ , 50 OHM

Small Signal Gain vs. Frequency

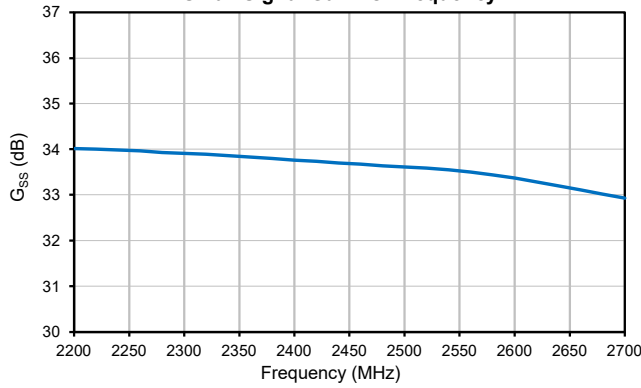

Noise Figure vs. Frequency

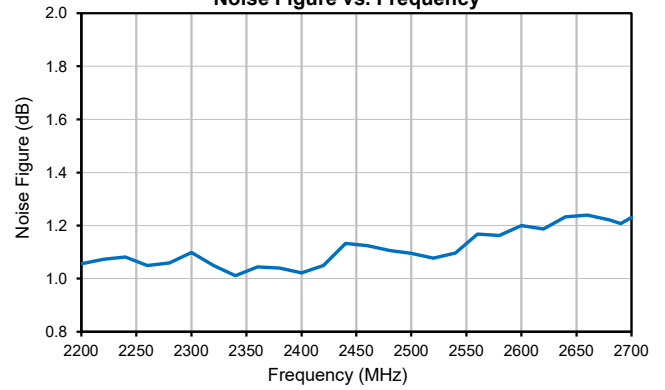

Input VSWR vs. Frequency

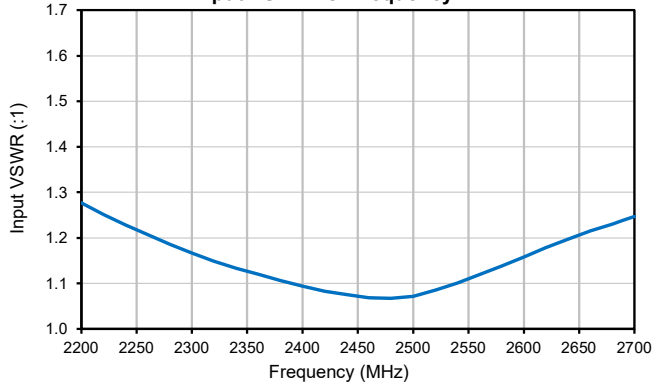

Output VSWR vs. Frequency

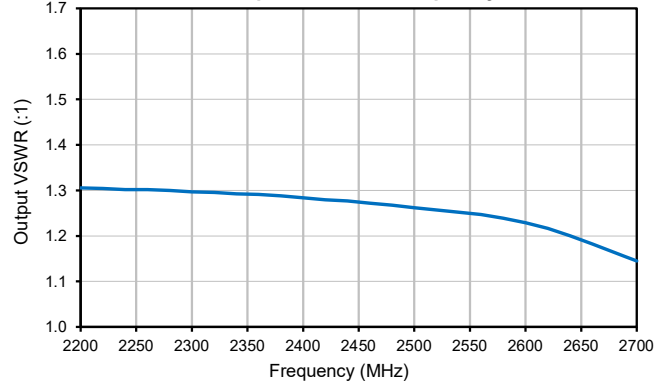

Output Power at 1 dB Compression vs. Frequency

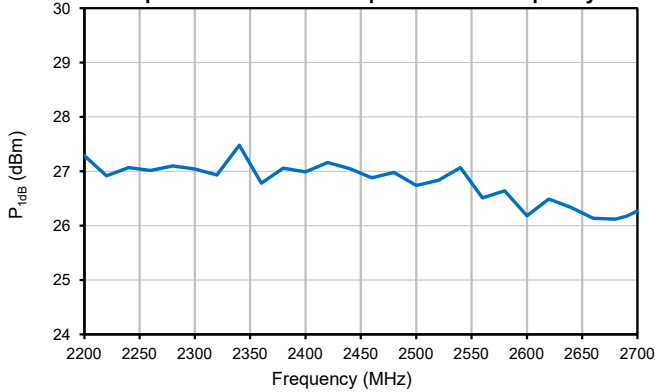

Output Third Order Intercept Point vs. Frequency

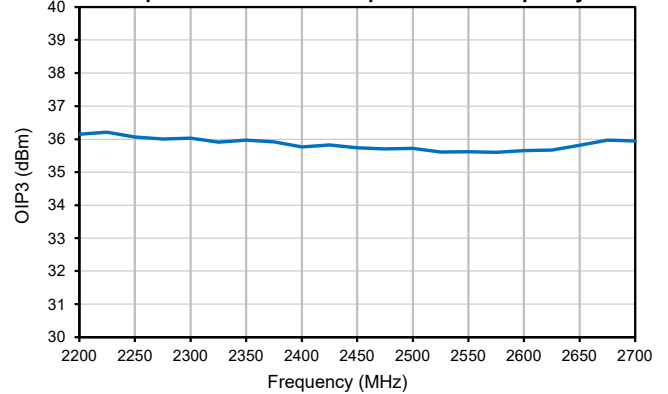



COAXIAL

# Low Noise Amplifier **ZQL-2G22G70W3+**

50Ω 2200 to 2700 MHz 0.5 W SMA-Female

## ABSOLUTE MAXIMUM RATINGS

Parameter	Ratings
Operating Temperature	T <sub>AMBIENT</sub> : -40 °C to +70 °C T <sub>MOUNTINGBASE</sub> : -20 °C to +80 °C
Storage Temperature	-55 °C to +100 °C
No damage with an open or short at P <sub>OUT</sub> = +25 dBm CW	
RF Input Power (no damage)	+3 dBm with the load connected -12 dBm with no load connected
DC Operating Voltage (Vs)	± 17 V

Permanent damage may occur if any of these limits are exceeded.

## DETERMINING MAXIMUM THERMAL RESISTANCE OF USERS' EXTERNAL HEAT SINK

MAXIMUM THERMAL RESISTANCE	$= \frac{\text{MAXIMUM OPERATING CASE TEMP} - \text{MAXIMUM USER AMBIENT TEMP}}{\text{POWER DISSIPATION}}$
<b>Example:</b>	MAXIMUM OPERATING CASE TEMP = +80 °C (CHECK MAXIMUM RATINGS TABLE FOR THIS VALUE) MAXIMUM USER AMBIENT TEMP = +70 °C (USER DEFINED) POWER DISSIPATION = 5.78 WATTS (CHECK MAXIMUM RATINGS TABLE FOR THIS VALUE) THEN MAXIMUM ALLOWABLE THERMAL RESISTANCE = 1.73 °C/W



COAXIAL

# Low Noise Amplifier **ZQL-2G22G70W3+**

Mini-Circuits

50Ω 2200 to 2700 MHz 0.5 W SMA-Female

## COAXIAL CONNECTIONS

IN (RF IN)	SMA-Female
OUT (RF OUT)	SMA-Female

## CASE STYLE DRAWING

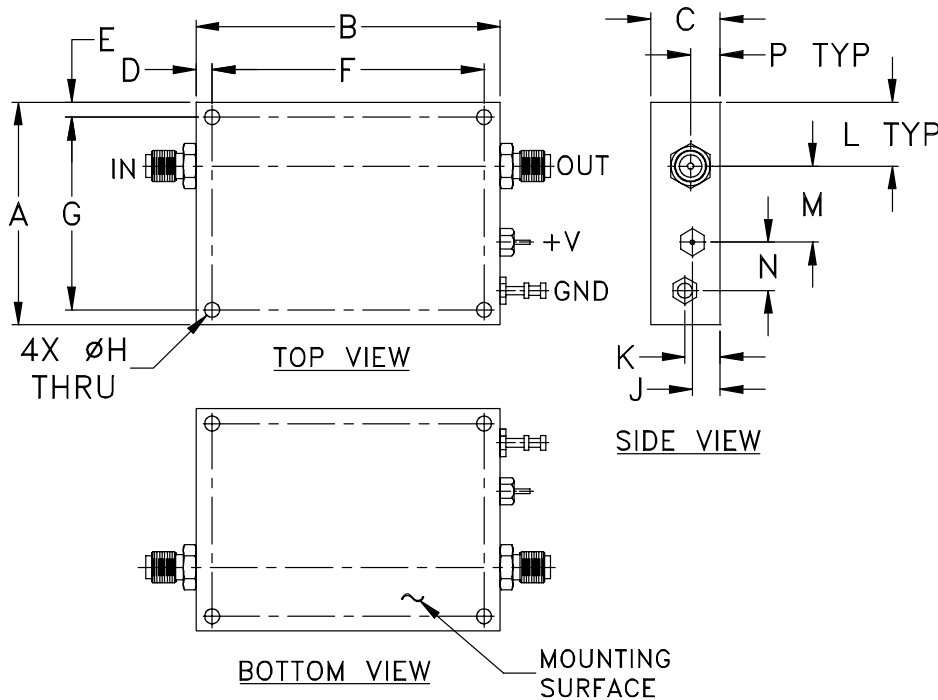

CASE#	A	B	C	D	E	F	G	H	J	K	L	M	N
CW686	1.77 (44.96)	2.42 (61.47)	.55 (13.97)	.13 (3.30)	.12 (3.05)	2.165 (54.99)	1.535 (38.99)	.126 (3.20)	.22 (5.59)	.28 (7.11)	.51 (12.95)	.61 (15.49)	.39 (9.91)

CASE#	P	Q	WT. GRAMS
CW686	.22 (5.59)	--	71

Dimensions are in inches (mm). Tolerances: 2 Pl. ± .03; 3 Pl. ± .015



COAXIAL

# Low Noise Amplifier **ZQL-2G22G70W3+**

50Ω 2200 to 2700 MHz 0.5 W SMA-Female

**ADDITIONAL INFORMATION IS AVAILABLE ON OUR DASHBOARD.**

Performance Data & Graphs	Data
	Graphs
	S-Parameter (S2P Files) Data Set (.zip file)
RoHS Status	Compliant
Environmental Ratings	ENV26

**ORDERING INFORMATION**

Model No. Links	<a href="#">ZQL-2G22G70W3+</a>
Case Style	CW686
Connector	IN (SMA-Female) / OUT (SMA-Female)

- NOTES**
- A. Performance and quality attributes and conditions not expressly stated in this specification document are intended to be excluded and do not form a part of this specification document.
  - B. Electrical specifications and performance data contained in this specification document are based on Mini-Circuit's applicable established test performance criteria and measurement instructions.
  - C. The parts covered by this specification document are subject to Mini-Circuits standard limited warranty and terms and conditions (collectively, "Standard Terms"); Purchasers of this part are entitled to the rights and benefits contained therein. For a full statement of the standard terms and the exclusive rights and remedies thereunder, please visit Mini-Circuits' website at [www.minicircuits.com/terms/viewterm.html](http://www.minicircuits.com/terms/viewterm.html)



# Coaxial Amplifier

# ZQL-2G22G70W3+

## Typical Performance Data

Frequency (MHz)	Gain (dB) 15V	Noise Figure (dB) 15V	VSWR (:1)		P <sub>OUT</sub> @ 1dB Compression (dBm) 15V	Frequency (MHz)	OIP3 (dBm) 15V
			IN	OUT			
			15V	15V			
2200	34.01	1.06	1.28	1.31	27.29	2200	36.16
2220	34.00	1.07	1.25	1.30	26.92	2225	36.21
2240	33.99	1.08	1.23	1.30	27.07	2250	36.06
2260	33.96	1.05	1.21	1.30	27.02	2275	36.01
2280	33.93	1.06	1.19	1.30	27.10	2300	36.03
2300	33.91	1.10	1.17	1.30	27.04	2325	35.90
2320	33.89	1.05	1.15	1.30	26.94	2350	35.97
2340	33.86	1.01	1.13	1.29	27.48	2375	35.92
2360	33.83	1.04	1.12	1.29	26.78	2400	35.76
2380	33.80	1.04	1.11	1.29	27.05	2425	35.83
2400	33.77	1.02	1.09	1.28	26.99	2450	35.74
2420	33.73	1.05	1.08	1.28	27.16	2475	35.70
2440	33.70	1.13	1.07	1.28	27.05	2500	35.71
2460	33.67	1.12	1.07	1.27	26.88	2525	35.61
2480	33.64	1.11	1.07	1.27	26.98	2550	35.62
2500	33.61	1.10	1.07	1.26	26.74	2575	35.60
2520	33.59	1.08	1.09	1.26	26.84	2600	35.65
2540	33.55	1.10	1.10	1.25	27.07	2625	35.66
2560	33.50	1.17	1.12	1.25	26.51	2650	35.81
2580	33.44	1.16	1.14	1.24	26.64	2675	35.97
2600	33.37	1.20	1.16	1.23	26.18	2700	35.95
2620	33.29	1.19	1.18	1.22	26.49		
2640	33.20	1.23	1.20	1.20	26.34		
2660	33.11	1.24	1.22	1.18	26.14		
2680	33.01	1.22	1.23	1.16	26.12		
2690	32.97	1.21	1.24	1.15	26.17		
2700	32.93	1.23	1.25	1.15	26.27		

## Typical Performance Curves

### Small Signal Gain vs. Frequency

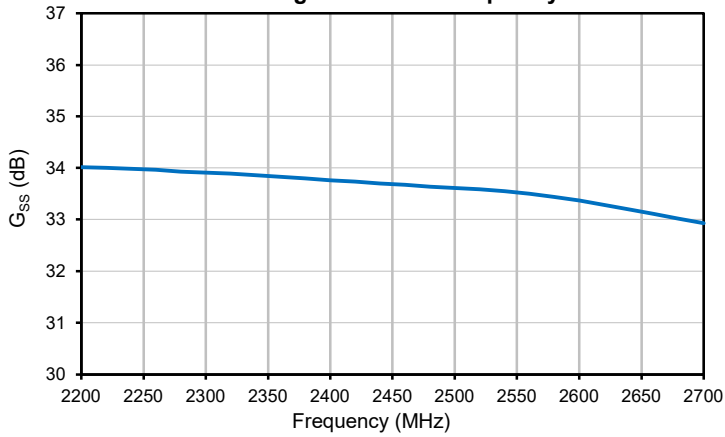

### Noise Figure vs. Frequency

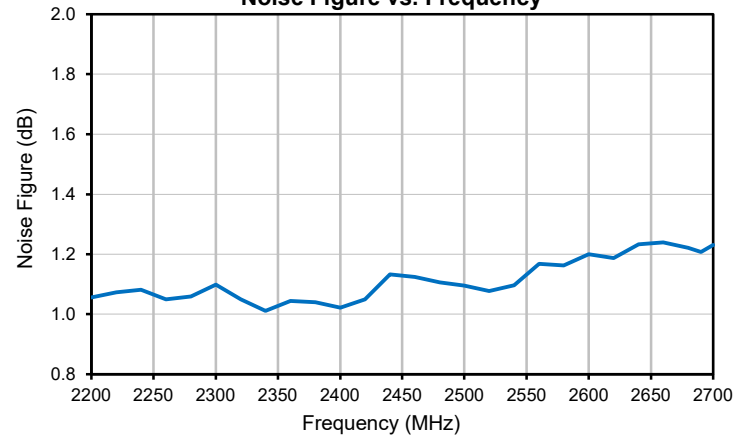

### Input VSWR vs. Frequency

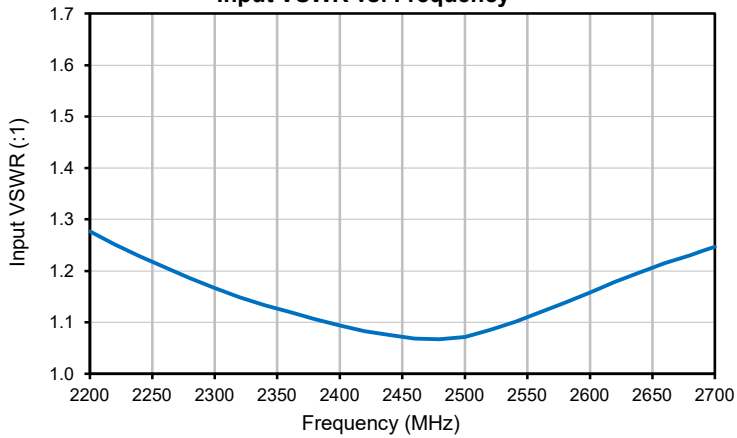

### Output VSWR vs. Frequency

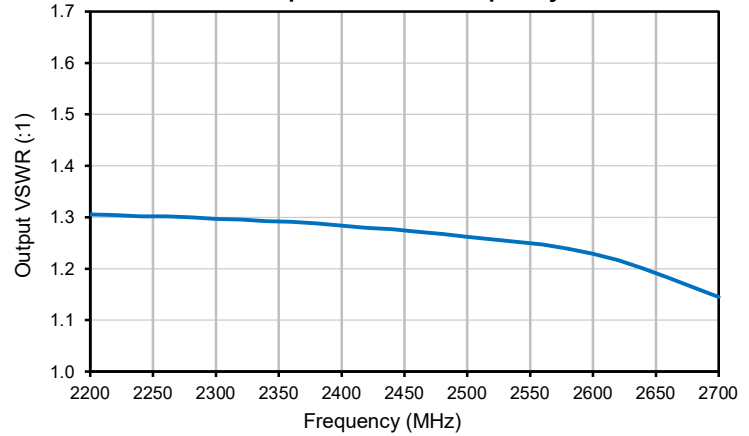

### Output Power at 1 dB Compression vs. Frequency

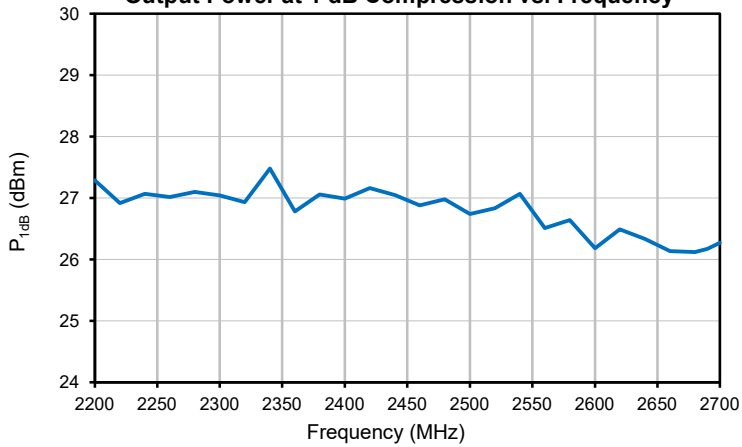

### Output Third Order Intercept Point vs. Frequency

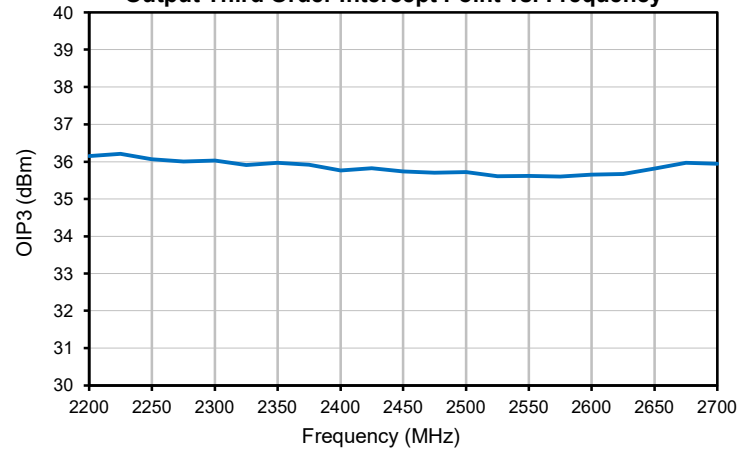

### Outline Dimensions

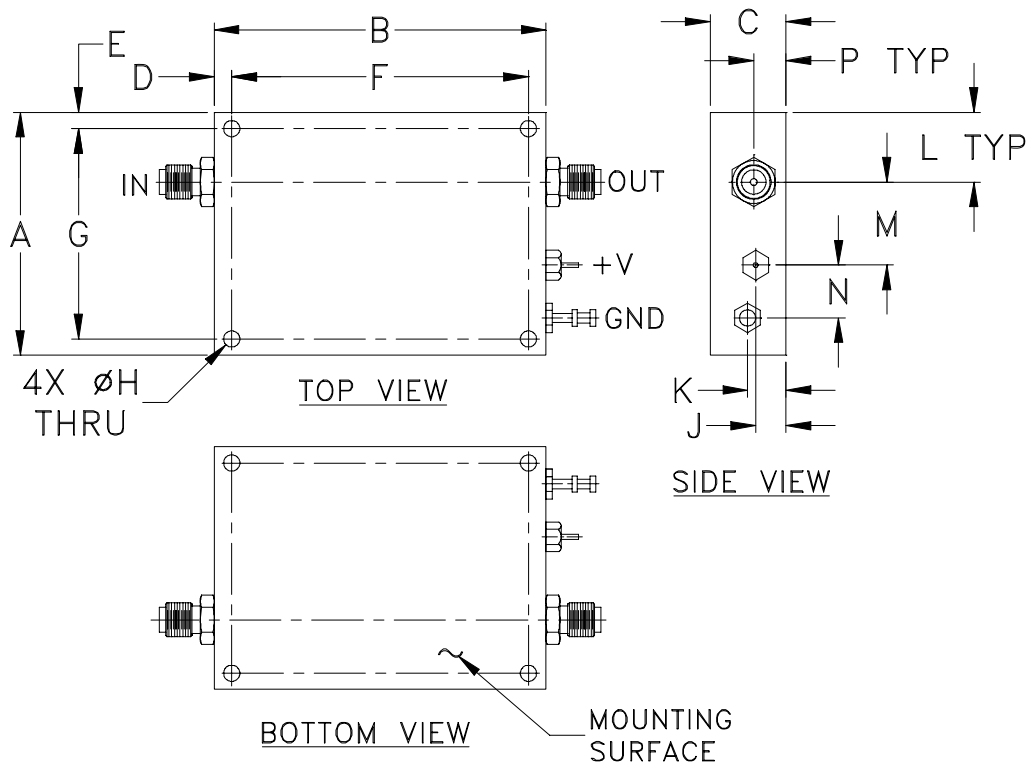

CASE#	A	B	C	D	E	F	G	H	J	K	L	M	N
CW686	1.77 (44.96)	2.42 (61.47)	.55 (13.97)	.13 (3.30)	.12 (3.05)	2.165 (54.99)	1.535 (38.99)	.126 (3.20)	.22 (5.59)	.28 (7.11)	.51 (12.95)	.61 (15.49)	.39 (9.91)

CASE#	P	Q	WT. GRAMS
CW686	.22 (5.59)	--	71

Dimensions are in inches (mm). Tolerances: 2 Pl.  $\pm .03$ ; 3 Pl.  $\pm .015$

#### Notes:

- Case material: Aluminum alloy.
- Case finish:  
For RoHS Case Styles: Clear chemical conversion coating, non-chrome or trivalent chrome based.

All Mini-Circuits products are manufactured under exacting quality assurance and control standards, and are capable of meeting published specifications after being subjected to any or all of the following physical and environmental test.

Specification	Test/Inspection Condition	Reference/Spec
Operating Temperature	-40° to 70° C Ambient Environment	Individual Model Data Sheet
Storage Temperature	-55° to 100° C Ambient Environment	Individual Model Data Sheet
Stabilization Bake	(non-operating) 125°C, 24 hours	- - -
Burn-in at Elevated Temp.	(DC on) 160 hours at 85° C	MIL-STD-202, Method 108
Thermal Shock	-55° to 85°C, 5 cycles	MIL-STD-202, Method 107, Condition A