



THE BIG DEAL

- 6 x 4 L-band signal routing matrix
- Dual redundant power supply
- Convenient rack-mountable chassis
- Fail-safe / redundancy switching
- LED power supply indicators



Front View



Back View

Generic photo used for illustration purposes only

APPLICATIONS

- Benchtop and rack-mounted automated test systems
- L-band satcom uplink / downlink signal routing
- GNSS (GPS, Galileo, GLONASS) signal distribution
- Military radio, radar & electronic warfare

FUNCTIONAL BLOCK DIAGRAM

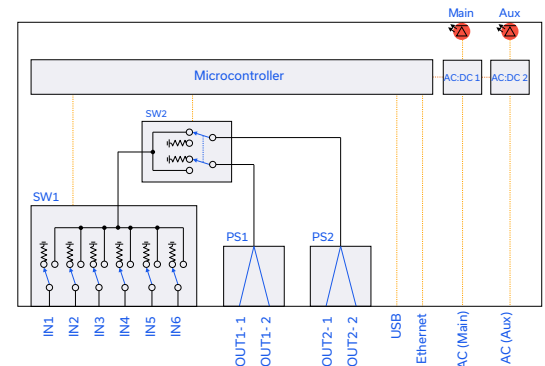

PRODUCT OVERVIEW

Mini-Circuits' ZT-272 is a highly reliable signal routing matrix, switching and splitting any of 6 inputs to either of the 2 pairs of output ports. The matrix has low loss over a very wide bandwidth from 5 to 2700 MHz, covering a range of VHF, UHF and L-band applications including military radio and satcom signal distribution.

The matrix is housed in a compact 19-inch rack chassis, 2U height, with all SMA (female) RF connectors on the rear panel. The assembly can be controlled via USB or Ethernet (supporting HTTP and Telnet network protocols). Full software support is provided, including our user-friendly GUI application for Windows and a full API with programming instructions for Windows and Linux environments.

The system includes a dual redundant power supply configuration which ensures reliable long-term operation in environments where interruptions in service cannot be tolerated. Connecting the two AC power supply inputs to separate AC sources ensures the system can continue operation in the event of a failure in either one of them. The system will seamlessly transition to the auxiliary AC source in the event of an interruption to the main source and then back when the main source is restored; all without any interruption or down time to switch operation and communication.

KEY FEATURES

Feature	Advantages
Mechanical switches	Mechanical absorptive switches provide low loss, high isolation, high reliability, repeatable performance and internal termination of input signals on the disconnected paths
Dual redundant power supply	Separate internal power supply units and connections for 2 separate external AC sources ensure reliable operation. The system will seamlessly switch between the main and auxiliary AC inputs in the event of a failure in either source, with no downtime or interruption to operation.
Fail-safe design	The switches revert to a known default state when the DC supply is removed, allowing their use in systems that must continue to operate safely in the event of power failure
Ethernet & USB control	USB HID and Ethernet (HTTP & Telnet) interfaces ensure compatibility with most software environments and connection requirements.
Rack-mount chassis	Compact 2U height, 19" rack-mountable chassis suits integration in automated production test environments.

REV. B
ECO-023008
ZT-272
MCL NY
240911



ELECTRICAL SPECIFICATIONS AT +25°C (EACH SWITCH)

Parameter	Conditions	Min.	Typ.	Max.	Units
Frequency Range	-	5		2700	MHz
Insertion Loss	5-1500 MHz		4.0	5.0	dB
	1500-2700 MHz		5.0	6.0	
Isolation	Inactive Paths ¹	80	95		dB
	Between IN ports	80	95		
	Between adjacent OUT ports	13	18		
Return Loss ²			15		dB
Switching Time			25		ms
RF Input Power (Cold Switching)	IN ports (cold switching)			+30	dBm
	IN ports (hot switching) ³			+20	
	OUT ports (per port)			+10	
Switch Lifetime	100 mW hot switching ³	10			million cycles
	1W hot switching		1		

1. Isolation measured between any IN port and any disconnected pair of OUT ports. Example: Isolation for IN1 to OUT1-1 is the leakage measured at OUT1-1 from a signal input at IN1 when the active switch path is set to IN2 to OUT1-1.

2. Return loss for all ports when terminated in 50Ω and any switch path is set

3. Hot switching power above this level will degrade the switch lifetime

**CONTROL INTERFACES**

Ethernet Control	Supported Protocols	TCP / IP, HTTP, Telnet, DHCP, UDP (limited)
	Max Data Rate	10 Mbps (10 Base-T Half Duplex)
USB Control	Supported Protocols	HID – Full Speed
	Min Communication Time	3 ms typ

1. Based on the polling interval of the USB HID protocol (1 ms with 64 bytes per packet) and no other significant CPU or USB activity

SOFTWARE & DOCUMENTATION

Mini-Circuits' full software and support package including user guide, Windows GUI, API, programming manual and examples can be downloaded free of charge (refer to the last page for the download path).

A comprehensive set of software control options is provided:

- GUI for Windows – Simple software interface for control via Ethernet and USB
- Programming / automation via Ethernet
 - Complete set of control commands which can be sent via any supported protocol – simple to implement in the majority of modern programming environments
- Programming / automation via USB
 - DLL files provide a full API for Windows with a set of intuitive functions which can be implemented in any programming environment supporting .Net Framework or ActiveX
 - Direct USB programming is possible in any other environment (not supporting .Net or ActiveX)

Please contact testsolutions@minicircuits.com for support

MINIMUM SYSTEM REQUIREMENTS

Hardware	Intel i3 (or equivalent) or later
GUI (USB or Ethernet Control)	Windows 7 or later
USB API DLL	Windows 7 or later with support for Microsoft .Net Framework or ActiveX
USB Direct Programming	Windows 7 or later; Linux
Ethernet	Windows, Linux or macOS with Ethernet TCP / IP support

PROGRAMMING COMMANDS

The key ASCII / SCPI commands for control of the system for control via the Ethernet or USB API are summarized below (refer to the programming manual for full details):

Command / Query	Description
:MN?	Read model name
:SN?	Read serial number
:FIRMWARE?	Read firmware version
:C[sw_number]=[port]	Set a single switch state: <ul style="list-style-type: none"> • [sw_number] = Switch number (1 to 2) • [port] = The port to be connected to Com of the specified switch (1 to 2) • Example: C1=2
:GetSSW[sw_number]?	Get the state of a switch: <ul style="list-style-type: none"> • [sw_number] = Switch number (1 to 2) • Example: GetSSW1?
:PSU:[psu_number]?	Check the power supply status <ul style="list-style-type: none"> • [psu_number] = 1 for main power supply or 2 for auxiliary power supply • Returns an integer to indicate whether the power supply is connected (1 for connected and available, 0 for disconnected / not available) • Example :PSU:1? Note: Power will always be drawn from the main power supply input when available



GRAPHICAL USER INTERFACE (GUI) FOR WINDOWS - KEY FEATURES

- Connect via USB or Ethernet
- Run GUI in "demo mode" to evaluate software without a hardware connection
- View and set all switch states at the click of a button
- View dual redundant power supply operation
- Configure Ethernet settings
- Update firmware

The screenshot shows the Mini-Circuits ZT-272 GUI. At the top, it displays 'Main Control' with 'Help' and 'Block Diagram' buttons. The 'Set Path' section has 'From' (In1) and 'To' (Out2) dropdowns, along with 'Show Command', 'Save to Quick Set Button', and 'SEND' buttons. The central area shows 'Model Name' (ZT-272), 'Serial Number' (02312180001 - USB), 'Protocol' (USB), 'IP', and 'Password' fields. Below these are 'Firmware Upgrade' and 'Ethernet Config' buttons, and a 'Connection Status' indicator showing 'Connected'. The 'Quick-Set Buttons' section features a grid of 20 buttons labeled 'EMPTY1' through 'EMPTY20' under tabs 'TAB1 (Empty)' to 'TAB5 (Empty)', with 'Modify Buttons', 'Load Config', and 'Clear All' options. The 'Manual Commands' section includes dropdowns for 'Switch Commands' (C2=2), 'Switch States', 'Switch Counters', and 'Additional Commands', with a 'SEND' button. A 'Command History' window shows a list of commands and their successful results. On the right, there are two status tables: 'Switch Status' and 'System Status'.

Switch	State	Count
1	6	1
2	2	2

Temperature	Normal
Fan operation	OK
Fan state	OFF
Main PSU	In use
Aux PSU	Available

- The GUI includes notifications to confirm which AC inputs (Main and Aux) are connected:

Notification	Description
In Use	The AC input (either Main or Aux) is connected and currently in use for powering the system
Available	The Aux AC input is connected and currently in standby mode (the Main AC input is powering the system)
Not Available	The AC input (either Main or Aux) is not detected, due to a physical disconnection or fault



TYPICAL PERFORMANCE GRAPHS

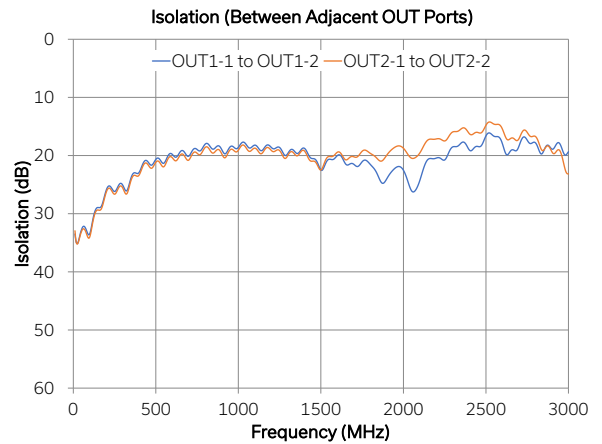
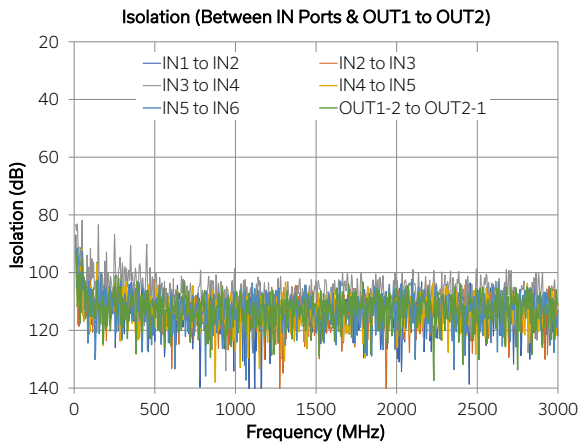
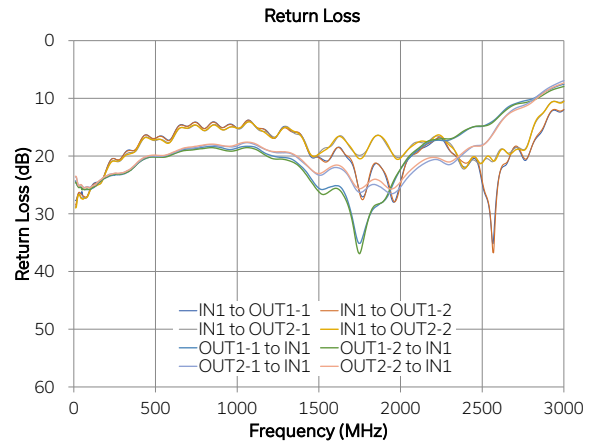
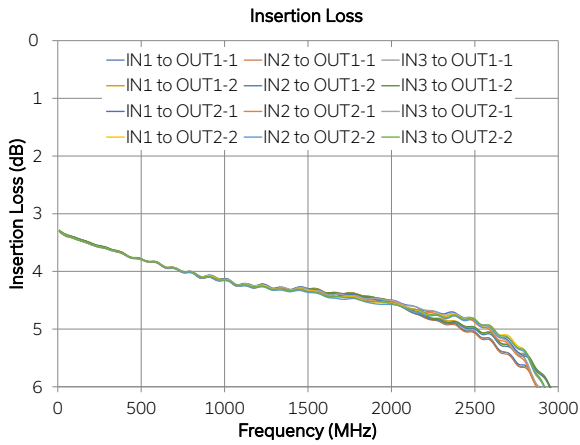



ABSOLUTE MAXIMUM RATINGS

Parameter	Conditions	Limits	Units
Temperature	Operating	0 to +50	°C
	Storage	-20 to +60	
Input Power (No Damage)	IN ports (cold switching)	+30	dBm
	IN ports (hot switching)	+20	
	OUT ports (per port)	+10	

Permanent damage may occur if any of these limits are exceeded. Operating in the range between operating power limits and absolute maximum ratings for extended periods of time may result in reduced life and reliability.

POWER SUPPLY

Power Supply	Dual redundant AC mains input: 2 x 100-240 V, 50 / 60 Hz
Fuse	2A, 250V rating per power supply
Power Consumption	150W maximum

SWITCH STATE TABLE

Switch Command	Switch Path
C1=1;C2=1	IN1 to OUT1-1 & OUT1-2
C1=2;C2=1	IN2 to OUT1-1 & OUT1-2
C1=3;C2=1	IN3 to OUT1-1 & OUT1-2
C1=4;C2=1	IN4 to OUT1-1 & OUT1-2
C1=5;C2=1	IN5 to OUT1-1 & OUT1-2
C1=6;C2=1	IN6 to OUT1-1 & OUT1-2
C1=1;C2=2	IN1 to OUT2-1 & OUT2-2
C1=2;C2=2	IN2 to OUT2-1 & OUT2-2
C1=3;C2=2	IN3 to OUT2-1 & OUT2-2
C1=4;C2=2	IN4 to OUT2-1 & OUT2-2
C1=5;C2=2	IN5 to OUT2-1 & OUT2-2
C1=6;C2=2	IN6 to OUT2-1 & OUT2-2

CONNECTIONS

Port	Connector
IN1 to IN 6	SMA female
OUT1-1 to OUT1-2	SMA female
OUT2-1 to OUT2-2	SMA female
USB	USB type B
Ethernet / LAN	RJ45
Main AC Input	IEC C14 inlet
Aux AC Input	IEC C14 inlet

POWER SUPPLY LED LOGIC

MAIN LED	AUX LED	Power Supply State
Off	Off	Main & Aux disconnected - System powered off
Off	On	Main disconnected / Aux connected - Aux is powering the system
On	Off	Main connected / Aux disconnected - Main is powering the system
On	On	Main & Aux connected - Main is powering the system, Aux is available in standby

FUNCTIONAL BLOCK DIAGRAM

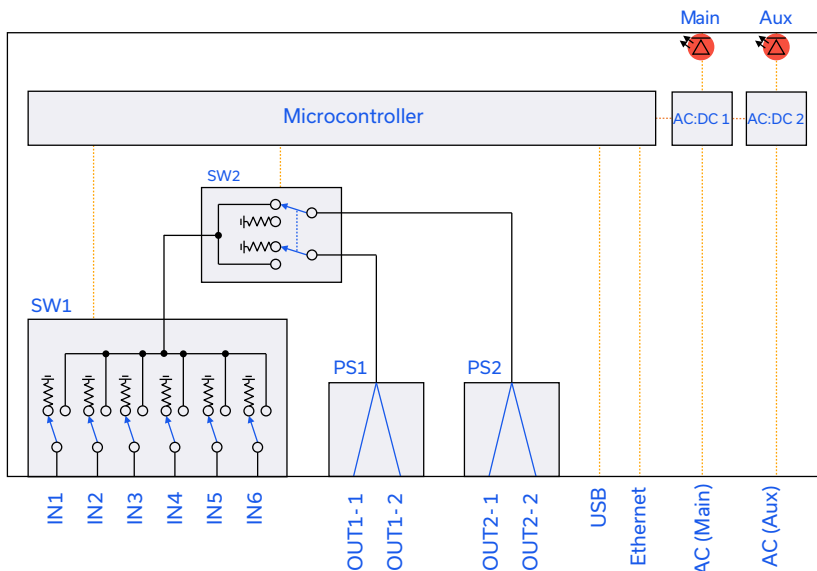



CASE STYLE DRAWING

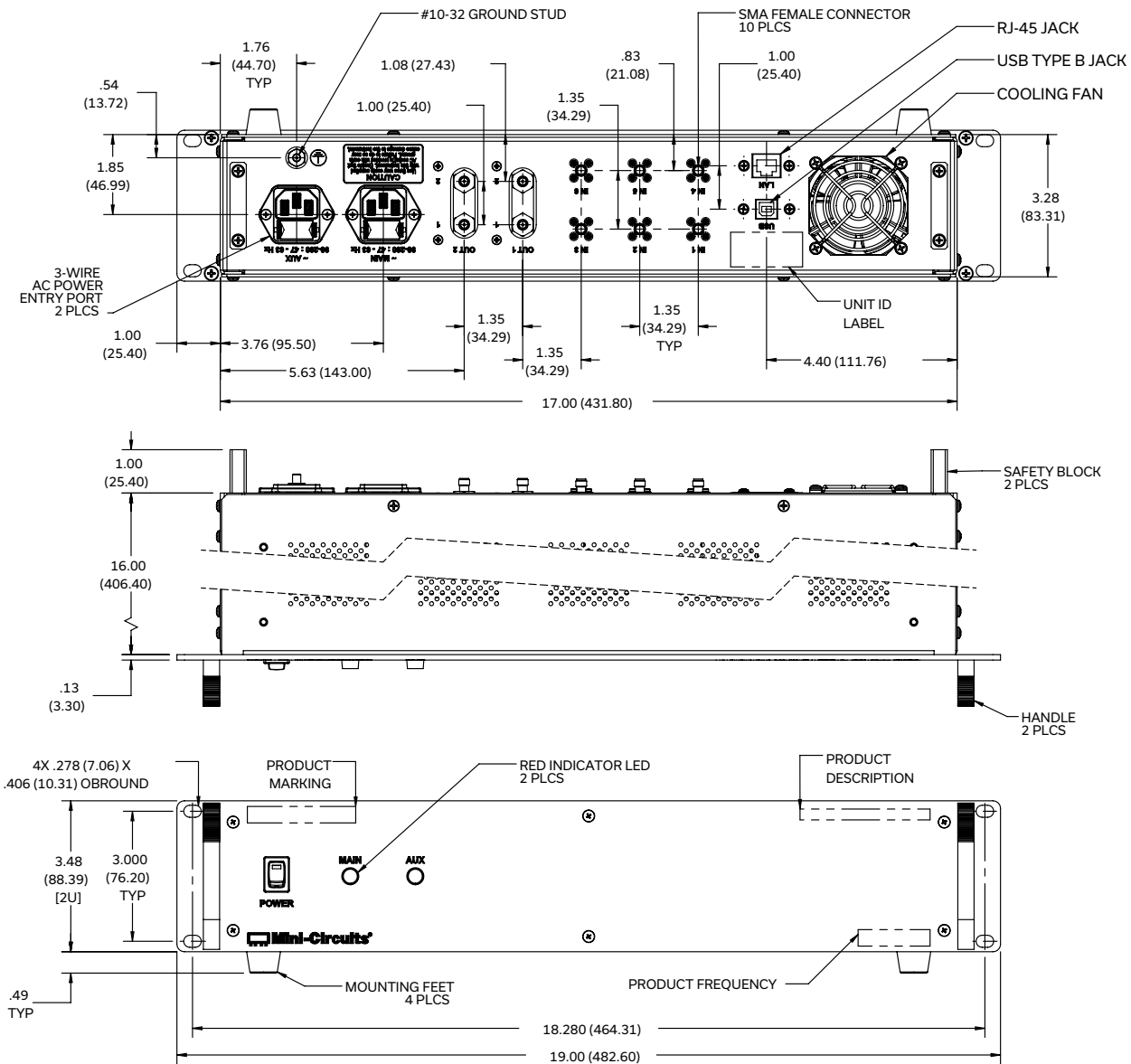

Weight: 4670 grams.

Dimensions are in inches (mm). Tolerances: 2 Pl. ±.03 inch; 3 Pl.± .015 inch.

PRODUCT MARKING*

Product Marking: ZT-272

Product Description: Command Uplink Switch

Product Frequency: 5-2700 MHz





Unit ID Label: Serial number and other identification marks





*Marking may contain other features or characters for internal lot control

DETAILED MODEL INFORMATION IS AVAILABLE ON OUR WEBSITE [CLICK HERE](#)

Case Style	AAZ2790	
Software, User Guide & Programming Manual	https://www.minicircuits.com/softwaredownload/zt_dps.html	
Environmental Rating	ENV55	
Regulatory Compliance	<p>Refer to our website for compliance methodologies and qualifications</p> 	www.minicircuits.com/quality/environmental_introduction.html

Contact Us: testsolutions@minicircuits.com

Included Accessories	Part Number	Description
	USB-CBL-AB-7+	USB cable (6.8ft) type A to type B
	CBL-RJ45-MM-5+	Ethernet cable (5 ft)
	HT-4-SMA	SMA connector wrench (4" length)
	2 x CBL-3W-xx	2 x AC power cords (IEC C13 connector to local plug). Select one option from the list below. Please contact testsolutions@minicircuits.com if your region is not listed.

AC Power Cord Options	Part Number	Description
	CBL-3W-US	USA NEMA 5-15 plug (type B) to IEC C13 connector
	CBL-3W-EU	Europe CEE 7/7 plug (type E/F) to IEC C13 connector
	CBL-3W-UK	UK BS-1363 plug (type G) to IEC C13 connector
	CBL-3W-AU	Australia & China AS/NZS 3112 plug (type I) to IEC C13 connector
	CBL-3W-IL	Israel SI-32 plug (type H) to IEC C13 connector

- NOTES**
- Performance and quality attributes and conditions not expressly stated in this specification document are intended to be excluded and do not form a part of this specification document.
 - Electrical specifications and performance data contained in this specification document are based on Mini-Circuit's applicable established test performance criteria and measurement instructions.
 - The parts covered by this specification document are subject to Mini-Circuits standard limited warranty and terms and conditions (collectively, "Standard Terms"); Purchasers of this part are entitled to the rights and benefits contained therein. For a full statement of the standard. Terms and the exclusive rights and remedies thereunder, please visit Mini-Circuits' website at www.minicircuits.com/MCLStore/terms.jsp

Outline Dimensions

AAZ2790

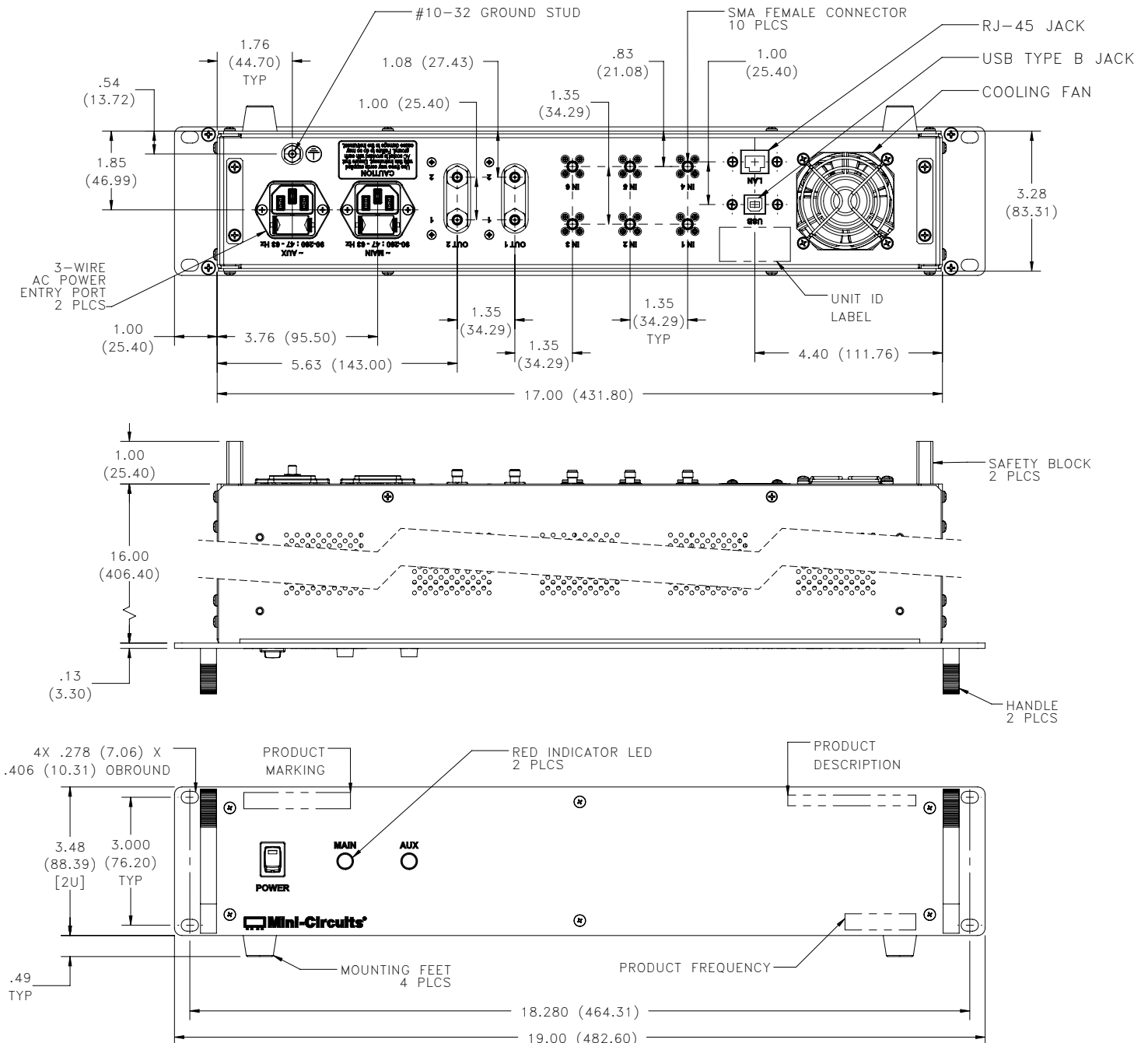

Notes:

1. Case material: Aluminum (with protective coating to prevent corrosion).
2. Dimensions are in inches (mm). Tolerances: 2 Pl. $\pm .03$ inch; 3 Pl. $\pm .015$ inch.
3. Weight: 4670 grams.
4. Marking may contain other features or characters for internal lot control.



P.O. Box 350166, Brooklyn, New York 11235-0003 (718) 934-4500 Fax (718) 332-4661 For detailed performance specs & shopping online see Mini-Circuits web site



The Design Engineers Search Engine Provides ACTUAL Data Instantly From MINI-CIRCUITS At: www.minicircuits.com

RF/IF MICROWAVE COMPONENTS



Environmental Specifications **ENV55**

All Mini-Circuits products are manufactured under exacting quality assurance and control standards, and are capable of meeting published specifications after being subjected to any or all of the following physical and environmental test.

Specification	Test/Inspection Condition	Reference/Spec
Operating Temperature	-0° to 50° C Ambient Environment	Individual Model Data Sheet
Storage Temperature	-20° to 60° C Ambient Environment	Individual Model Data Sheet
Operating and Storage Humidity	5% to 85% RH (non-condensing)	Ambient
Bench Handling Test	Bench Top Tip 45° & Drop	MIL-PRF-28800F
Transit Drop Test	Free Fall Drop, 20 cm (7.9 inches)	MIL-PRF-28800F Class 3