



4-CHANNEL

# Variable Gain Amplifier

ZT-414

Mini-Circuits

50Ω 50 to 300 MHz Rack-Mount SMA Female

## KEY FEATURES

- 4 x high gain amplifier channels
- Slim chassis to maximize rack availability
- 60 dB of gain control range per channel
- Integrated power supply & cooling
- Software automation via Ethernet & USB



Generic photo used for illustration purposes only

## APPLICATIONS

- Benchtop and rack-mounted automated test systems
- VHF signal routing & control
- Quantum computer read-out lines

## FUNCTIONAL BLOCK DIAGRAM

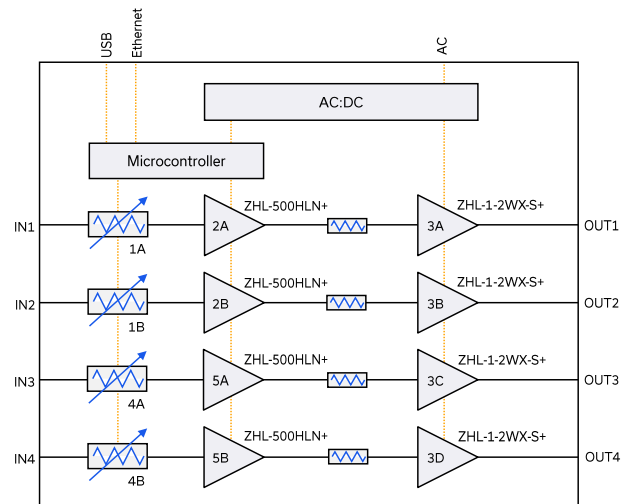

## PRODUCT OVERVIEW

Mini-Circuits' rack-mounted test solutions enable convenient integration of any combination of passive or active RF and microwave components within complex production test environments. A wide range of standard configurations are supplied from stock, with custom configurations available upon request.

ZT-414 integrates 4 independent amplifier channels covering 50 to 300 MHz. Each channel is comprised of 2 amplifier stages for high overall gain, with 60 dB of gain control range courtesy of an integrated programmable attenuator. The system is housed in a compact, 19-inch rack-mounted chassis with SMA female RF input connectors on the front panel and RF outputs on the rear.

All programmable attenuators can be individually controlled via USB or Ethernet (supporting HTTP and Telnet network protocols). Full software support is provided, including our user-friendly GUI application for Windows and a full API with programming instructions for Windows and Linux environments.

## ELECTRICAL SPECIFICATIONS AT +25°C<sup>1</sup>

Parameter	Conditions	Min.	Typ.	Max.	Units
Frequency Range	-	50		300	MHz
Gain / Loss	@ 0 dB attenuation	49	52		dB
	@ 60 dB attenuation		-8		
Return Loss	Input @ 0 dB attenuation		15		dB
	Output @ 0 dB attenuation		18		
Attenuation Range	0.25 dB step size	0		60	dB
Input Power				-20	dBm

1. Set all attenuator channels to maximum and apply 50 ohm loads to all RF outputs before applying the RF input and powering on. Set attenuator to maximum before turning amplifier off. All outputs must be terminated in 50 ohm at all times when powered on.





4-CHANNEL

# Variable Gain Amplifier

ZT-414

Mini-Circuits

50Ω 50 to 300 MHz Rack-Mount SMA Female

## TYPICAL PERFORMANCE GRAPHS

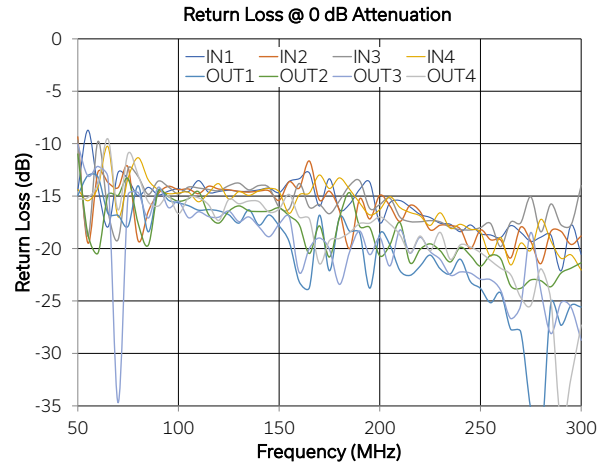
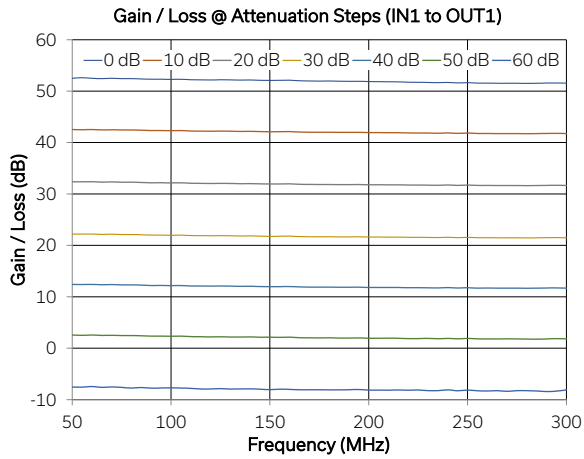
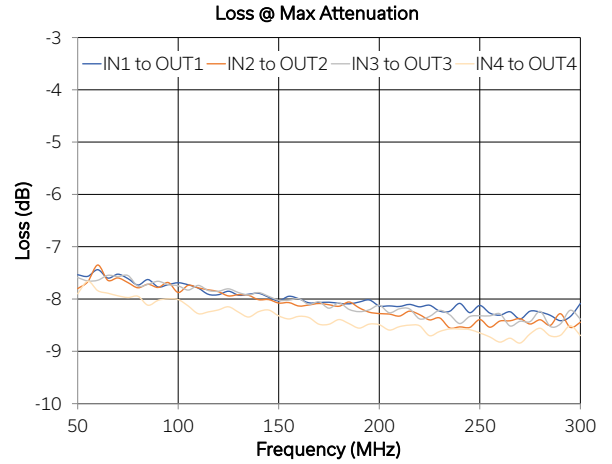
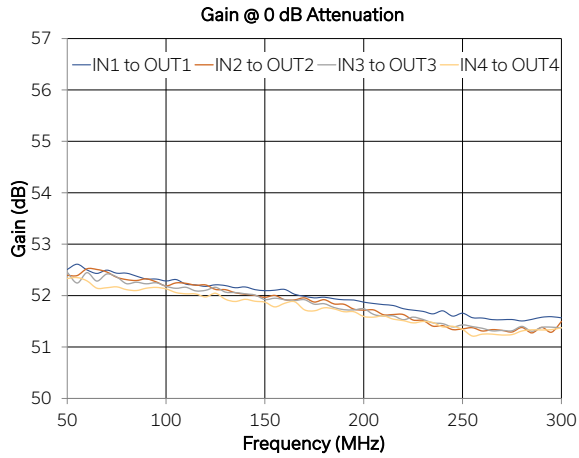

**CONTROL INTERFACES**

Ethernet Control	Supported Protocols	TCP / IP, HTTP, Telnet, DHCP, UDP (limited)
	Max Data Rate	10 Mbps (10 Base-T Half Duplex)
USB Control	Supported Protocols	HID – Full Speed
	Min Communication Time <sup>2</sup>	3 ms typ

2. Based on the polling interval of the USB HID protocol (125 μs with 64 bytes per packet) and no other significant CPU or USB activity

**SOFTWARE & DOCUMENTATION**

Mini-Circuits' full software and support package including user guide, Windows GUI, API, programming manual and examples can be downloaded free of charge (refer to the last page for the download path).

A comprehensive set of software control options is provided:

- GUI for Windows – Simple software interface for control via Ethernet and USB
- Programming / automation via Ethernet
  - Complete set of control commands which can be sent via any supported protocol – simple to implement in the majority of modern programming environments
- Programming / automation via USB
  - DLL files provide a full API for Windows with a set of intuitive functions which can be implemented in any programming environment supporting .Net Framework or ActiveX
  - Direct USB programming is possible in any other environment (not supporting .Net or ActiveX)

Please contact [testsolutions@minicircuits.com](mailto:testsolutions@minicircuits.com) for support

**MINIMUM SYSTEM REQUIREMENTS**

Hardware	Intel i3 (or equivalent) or later
GUI (USB or Ethernet Control)	Windows 7 or later
USB API DLL	Windows 7 or later with support for Microsoft .Net Framework or ActiveX
USB Direct Programming	Windows 7 or later; Linux
Ethernet	Windows, Linux or macOS with Ethernet TCP / IP support

**PROGRAMMING COMMANDS**

The key ASCII / SCPI commands for control of the system for control via the Ethernet or USB API are summarized below (refer to the programming manual for full details):

Command / Query	Description
:MN?	Read model name
:SN?	Read serial number
:FIRMWARE?	Read firmware version
:RUDAT:[address]:ATT:[value]	Set a single attenuator value: <ul style="list-style-type: none"> <li>• [address] = 1A, 1B, 4A, or 4B</li> <li>• [value] = attenuation value</li> <li>• Example :RUDAT:1A:ATT:20.25 (set attenuator 1A to 20.25 dB)</li> </ul>
:RUDAT:[address]:ATT?	Read a single attenuator value: <ul style="list-style-type: none"> <li>• [address] = 1A, 1B, 4A, or 4B</li> <li>• Example :RUDAT:1A:ATT? (read attenuator 1A value)</li> </ul>
:AMP:[address]:STATE:[value]	Power a single amplifier on / off: <ul style="list-style-type: none"> <li>• [address] = 2A, 2B, 5A, or 5B</li> <li>• [value] = amplifier state (off) or 2 (on)</li> <li>• Example :AMP:2A:STATE:2 (turn AMP 2A on)</li> </ul>
:AMP:[address]:STATE?	Check the state of a single amplifier: <ul style="list-style-type: none"> <li>• [address] = 2A, 2B, 5A, or 5B</li> <li>• Example :AMP:2A:STATE? (check the state of AMP 2A)</li> </ul>



4-CHANNEL

# Variable Gain Amplifier

ZT-414



50Ω 50 to 300 MHz Rack-Mount SMA Female

## GRAPHICAL USER INTERFACE (GUI) FOR WINDOWS

- Connect via USB or Ethernet
- Run GUI in "demo mode" to evaluate software without a hardware connection

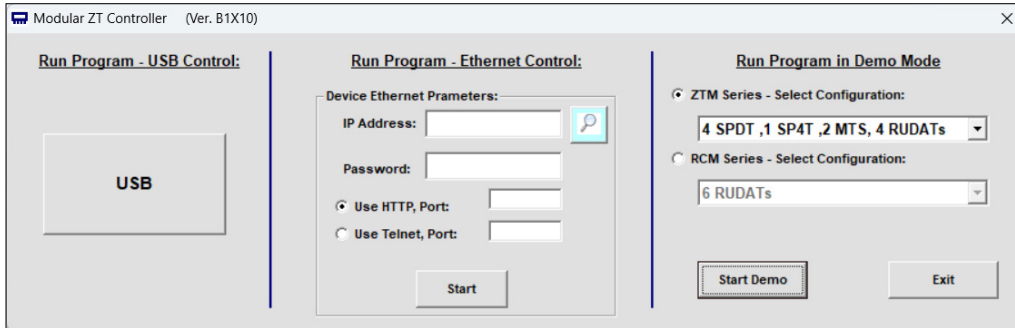

- View and set each attenuation values
- Enable / disable amplifiers
- Configure Ethernet settings
- Update firmware

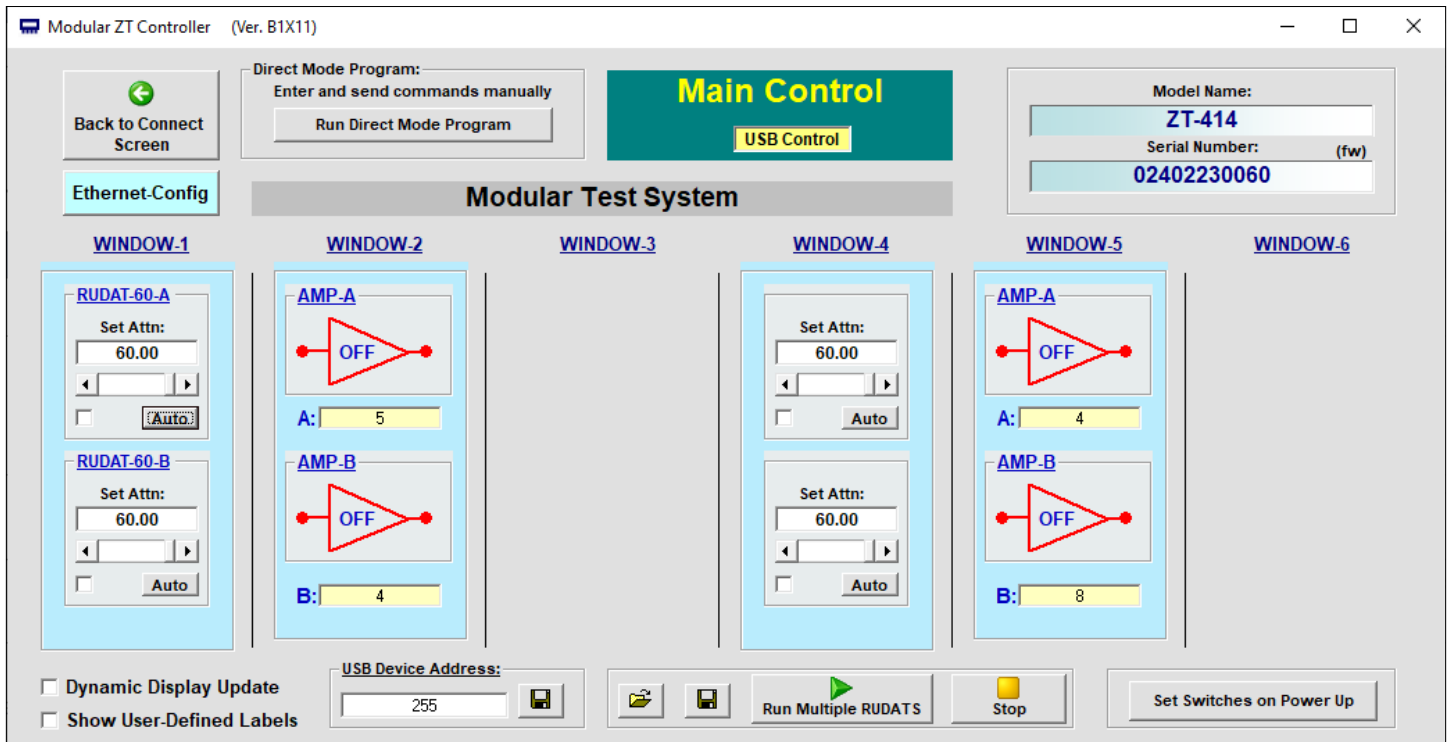



4-CHANNEL

# Variable Gain Amplifier

# ZT-414

Mini-Circuits

50Ω 50 to 300 MHz Rack-Mount SMA Female

### ABSOLUTE MAXIMUM RATINGS

Parameter	Conditions	Limits	Units
Temperature	Operating	0 to +50	°C
	Storage	-20 to +60	
Input Power (No Damage)		-20	dBm

Permanent damage may occur if any of these limits are exceeded. Operating in the range between operating power limits and absolute maximum ratings for extended periods of time may result in reduced life and reliability.

### POWER SUPPLY

Power Supply	AC mains input: 100-240 V, 50 / 60 Hz
Fuse	2 A, 250 V rating
Power Consumption	150 W maximum

### CONNECTIONS

Port	Connector
IN1-4 & OUT1-4	SMA female
USB	USB type B
Ethernet / LAN	RJ45
AC Input	IEC C14 inlet

### FUNCTIONAL BLOCK DIAGRAM

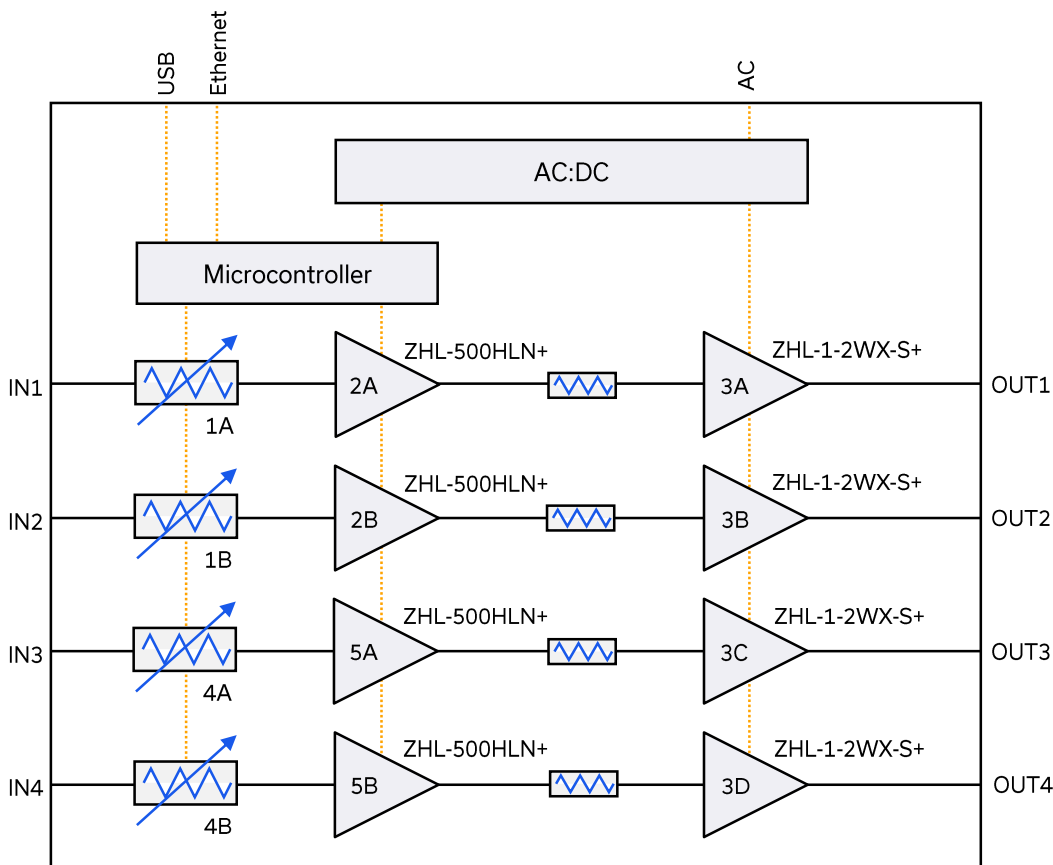

- A. Programmable attenuators 1A, 1B, 4A & 4B individually controllable from 0 to 60 dB in 0.25 dB steps
- B. Amplifiers 2A, 2B, 5A & 5B can be individually powered on & off through software
- C. Amplifiers 3A, 3B, 3C & 3D are permanently powered on with the ZT-414 unit; they cannot be individually controlled through software
- D. Refer to GUI image on page 4 for detail on addressing and control options





4-CHANNEL

# Variable Gain Amplifier

ZT-414

Mini-Circuits

50Ω 50 to 300 MHz Rack-Mount SMA Female

## CASE STYLE DRAWING

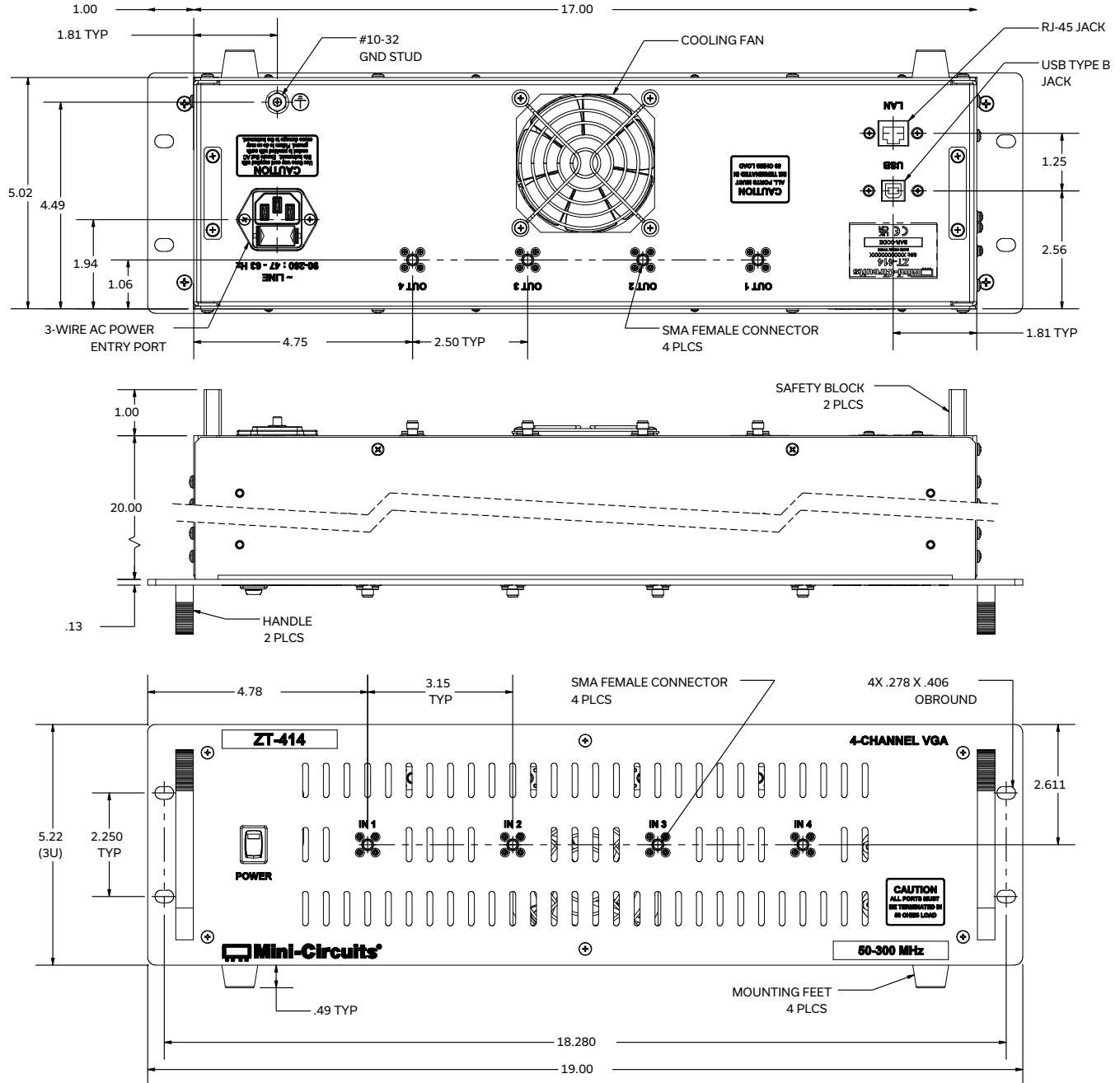

## PRODUCT MARKING\*

Product Marking: ZT-414

Product Description: 4-Channel VGA

Product Frequency: 50-300 MHz

Unit ID Label: Serial number and other identification marks

\*Marking may contain other features or characters for internal lot control





4-CHANNEL

# Variable Gain Amplifier

## ZT-414



Mini-Circuits





50Ω 50 to 300 MHz Rack-Mount SMA Female

DETAILED MODEL INFORMATION IS AVAILABLE ON OUR WEBSITE [CLICK HERE](#)

Case Style	99-01-3640
Software, User Guide & Programming Manual	<a href="http://www.minicircuits.com/softwaredownload/ztm_rcm.htm">www.minicircuits.com/softwaredownload/ztm_rcm.htm</a>
Environmental Rating	ENV55
Regulatory Compliance	<p>Refer to our website for compliance methodologies and qualifications</p>  <p><a href="http://www.minicircuits.com/quality/environmental_introduction.html">www.minicircuits.com/quality/environmental_introduction.html</a></p>

Contact Us: [testsolutions@minicircuits.com](mailto:testsolutions@minicircuits.com)

Included Accessories	Part Number	Description
	CBL-3W-xx	AC power cord (IEC C13 connector to local plug) Select one option from the list below. Please contact <a href="mailto:testsolutions@minicircuits.com">testsolutions@minicircuits.com</a> if your region is not listed.
	USB-CBL-AB-7+	USB cable (6.8ft) type A to type B
	CBL-RJ45-MM-5+	Ethernet cable (5 ft)
	HT-4-SMA	SMA connector wrench (4" length)

AC Power Cord Options	Part Number	Description
	CBL-3W-US	USA NEMA 5-15 plug (type B) to IEC C13 connector
	CBL-3W-EU	Europe CEE 7/7 plug (type E/F) to IEC C13 connector
	CBL-3W-UK	UK BS-1363 plug (type G) to IEC C13 connector
	CBL-3W-AU	Australia & China AS/NZS 3112 plug (type I) to IEC C13 connector
	CBL-3W-IL	Israel SI-32 plug (type H) to IEC C13 connector

- NOTES
- A. Performance and quality attributes and conditions not expressly stated in this specification document are intended to be excluded and do not form a part of this specification document.
  - B. Electrical specifications and performance data contained in this specification document are based on Mini-Circuit's applicable established test performance criteria and measurement instructions.
  - C. The parts covered by this specification document are subject to Mini-Circuits standard limited warranty and terms and conditions (collectively, "Standard Terms"); Purchasers of this part are entitled to the rights and benefits contained therein. For a full statement of the standard terms and the exclusive rights and remedies thereunder, please visit Mini-Circuits' website at [www.minicircuits.com/terms/viewterm.html](http://www.minicircuits.com/terms/viewterm.html)





Environmental Specifications **ENV55**

All Mini-Circuits products are manufactured under exacting quality assurance and control standards, and are capable of meeting published specifications after being subjected to any or all of the following physical and environmental test.

Specification	Test/Inspection Condition	Reference/Spec
Operating Temperature	-0° to 50° C Ambient Environment	Individual Model Data Sheet
Storage Temperature	-20° to 60° C Ambient Environment	Individual Model Data Sheet
Operating and Storage Humidity	5% to 85% RH (non-condensing)	Ambient
Bench Handling Test	Bench Top Tip 45° & Drop	MIL-PRF-28800F
Transit Drop Test	Free Fall Drop, 20 cm (7.9 inches)	MIL-PRF-28800F Class 3