



SUPER ULTRA

Wideband Amplifier

ZVA-183G-S+ ZVA-183GX-S+

50Ω 0.5 to 18 GHz

THE BIG DEAL

- Extremely wideband, 0.5 to 18 GHz
- Flat Gain, 38 ±2 dB
- High IP3, +36 dBm
- Medium power output, +36 dBm
- +27 dBm Pout

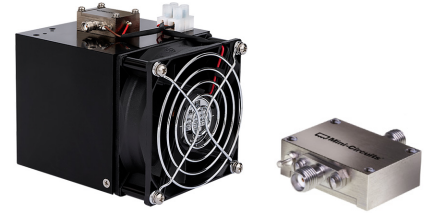

Generic photo used for illustration purposes only

APPLICATIONS

- Radar and military
- Test instrumentation
- Satellite repeaters
- Communication

Model No.	ZVA-183G-S+	ZVA-183GX-S+▲
Case Style	CP1755	
Connectors	SMA	

+RoHS Compliant
 The +Suffix identifies RoHS Compliance.
 See our website for methodologies and qualifications

PRODUCT OVERVIEW

Mini-Circuits' ZVA-183G+ is a Class-A, four-stage, unconditionally stable amplifier providing flat gain over an extremely wide frequency range from 0.5 to 18 GHz. This model is capable of delivering up to ½W output power at Psat with low noise and high IP3 supporting a wide range of sensitive, high-dynamic range receiver applications and many systems where high performance over wideband is needed. It operates on a +15V supply and features built-in safety features including protection against reverse bias and immunity to accidental open or short loads. The amplifier comes in a rugged, compact case (4.18 x 3.36 x 3.57") with SMA connectors and an optional heat sink for efficient cooling.

KEY FEATURES

Feature	Advantages
Ultra-wideband, 0.5 to 18 GHz	Enables a single amplifier to be used in a wide range of applications.
Excellent gain flatness, ±2.0 dB across full frequency range	Provides consistent performance across its operating frequency, minimizing the need for external equalizing networks in wideband applications.
High gain, 38 dB typ.	Reduces the number of gain stages, lowering component count and overall system cost.
Class A Amplifier	Provides good linearity with low signal distortion.
Low noise and high IP3: •NF, 3 dB typ. •IP3, +36 dBm typ.	The combination of low noise and high IP3 makes the ZX60-83LN+ ideal for use in low noise receiver front end (RFE) as it gives the user the advantages of sensitivity and two-tone IM performance at both ends of the dynamic range.
Rugged design	Built-in protection against reverse bias and accidental open and short loads provides added reliability for demanding operating conditions.





SUPER ULTRA

Wideband Amplifier

ZVA-183G-S+
ZVA-183GX-S+

Mini-Circuits

ELECTRICAL SPECIFICATIONS AT 25°C

Parameter	Condition (MHz)	ZVA-183G-S+ ZVA-183GX-S+ [▲]			Units
		Min.	Typ.	Max.	
Frequency Range		500	–	18000	MHz
Gain	500 - 18000	33	38	43	dB
Gain Flatness	500 - 18000	–	±2.0	±3.0	dB
Output Power at 1dB compression	500 - 18000	23	25	–	dBm
Output Power at 3dB compression	500 - 18000	25	27	–	dBm
Noise Figure	500 - 18000	–	3	5.5	dB
Output third order intercept point	500 - 18000	–	+36	–	dBm
Input VSWR	500 - 18000	–	1.9	3.0	:1
Output VSWR	500 - 18000	–	2.0	3.0	:1
DC Supply Voltage		14	15*	16	V
Supply Current ¹		–	700	770	mA

¹Power Supply should be capable of delivering 1A at start-up.

*Recommended Operating Voltage.

[▲]Heat sink not included. Alternative heat sinking and heat removal must be provided by the user to limit maximum base-plate temperature to 85°C, in order to ensure proper performance. For reference, this requires thermal resistance of user's external heat sink to be 1.79°C/W max.

MAXIMUM RATINGS

Parameter	Ratings
Operating Temperature	ZVA-183G+ -55°C to 60°C ambient
	ZVA-183GX+ -55°C to 85°C base plate temp.
Storage Temperature	-65°C to 150°C
DC Voltage	18V
CW Input RF Power (no damage)	+10 dBm

Permanent damage may occur if any of these limits are exceeded.





SUPER ULTRA

Wideband Amplifier

ZVA-183G-S+ ZVA-183GX-S+

OUTLINE DRAWING FOR MODEL WITH HEATSINK

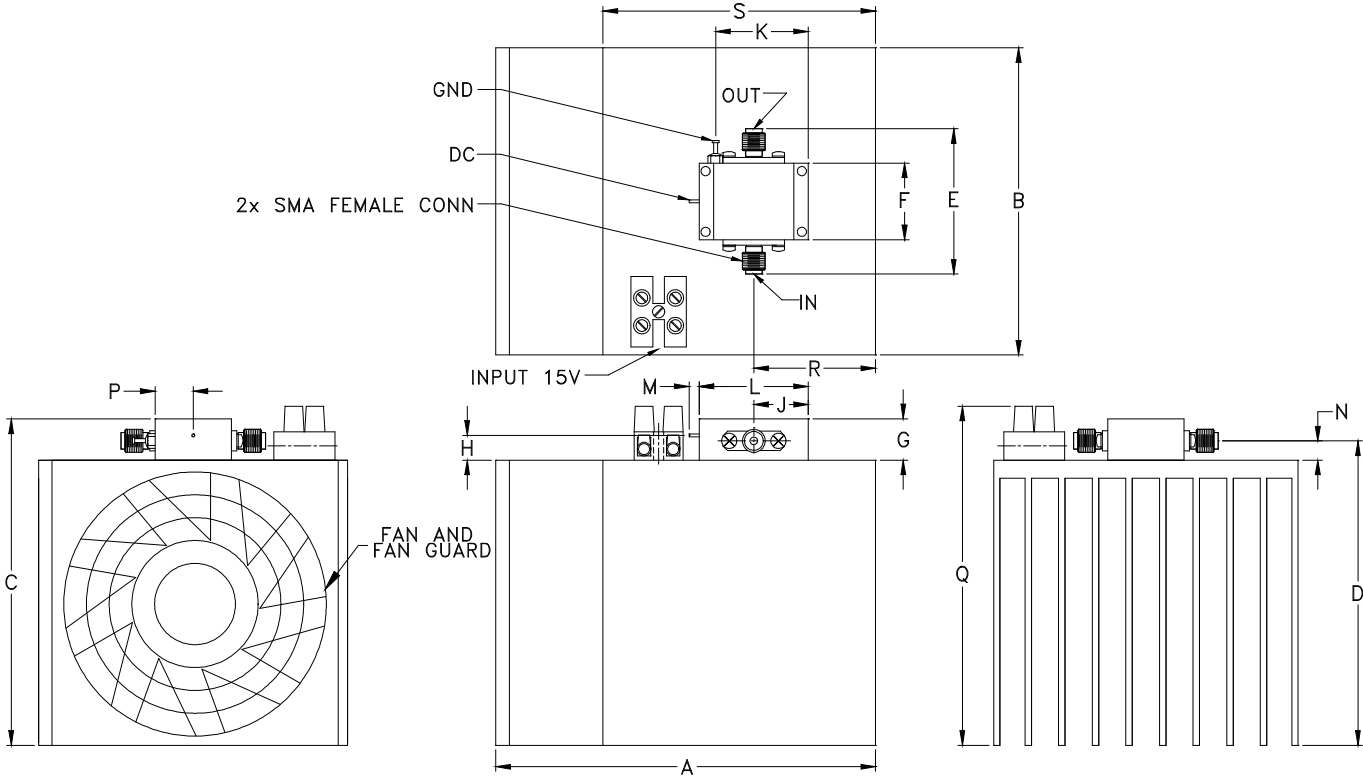

OUTLINE DRAWING FOR MODEL WITHOUT HEATSINK

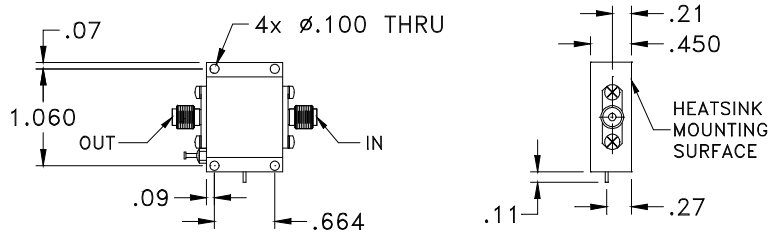

OUTLINE DIMENSIONS (INCH/MM)

A	B	C	D	E	F	G	H	J	K	L	M	N	P	Q	R	S	wt
4.18	3.36	3.57	3.33	1.59	.840	.45	0.27	.600	1.02	1.200	.11	.21	.420	3.71	1.34	3.00	grams*
106.17	85.34	90.68	84.58	40.39	21.34	11.43	6.86	15.24	25.91	30.48	2.79	5.33	10.67	94.23	34.04	76.20	480

*18.2 grams without heatsink





SUPER ULTRA

Wideband Amplifier

ZVA-183G-S+ ZVA-183GX-S+

Mini-Circuits

TYPICAL PERFORMANCE DATA/CURVES

Frequency (MHz)	Gain (dB)	Directivity (dB)	VSWR (:1)		POUT at 1 dB COMPR. (dBm)	POUT at 3 dB COMPR. (dBm)	Noise Figure (dB)	IP3 (dBm)
	15V	15V	IN	OUT	15V	15V	15V	15V
500	36.90	45.00	1.84	1.96	24.80	26.70	3.73	35.10
1000	38.70	51.00	1.61	1.70	26.10	28.10	2.67	36.60
2000	38.80	52.00	1.38	1.68	26.00	28.20	2.39	36.80
3000	39.30	54.00	1.47	1.39	26.60	28.70	2.37	37.10
4000	39.40	46.00	1.58	1.17	26.70	28.90	2.25	37.10
5000	39.40	48.00	1.54	1.14	27.40	29.60	2.25	37.20
6000	39.00	49.00	1.36	1.24	27.40	29.60	2.04	37.20
7000	38.80	57.00	1.27	1.19	27.50	29.50	2.06	37.20
8000	37.90	40.00	1.14	1.17	27.20	28.80	1.98	37.20
9000	37.60	47.00	1.19	1.12	26.80	28.70	2.09	36.80
10000	38.10	42.00	1.43	1.07	26.30	28.00	2.23	35.80
11000	38.10	49.00	1.49	1.15	26.20	27.80	2.21	35.60
12000	37.70	40.00	1.26	1.15	26.00	27.40	2.29	35.80
13000	38.10	40.00	1.17	1.03	25.60	27.20	2.34	35.60
14000	37.80	38.00	1.39	1.25	25.20	27.30	2.49	35.10
15000	36.90	40.00	1.49	1.53	25.20	27.30	2.59	34.70
16000	37.70	30.00	1.42	1.42	24.80	27.10	2.65	33.40
17000	37.10	32.00	1.42	1.37	24.70	26.60	2.70	33.20
18000	36.60	30.00	1.35	1.51	24.50	26.20	3.22	33.90

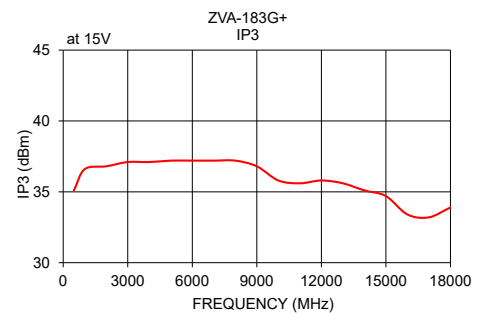
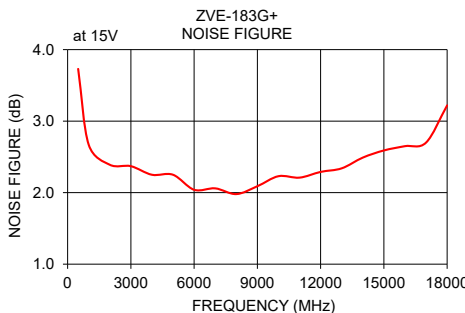
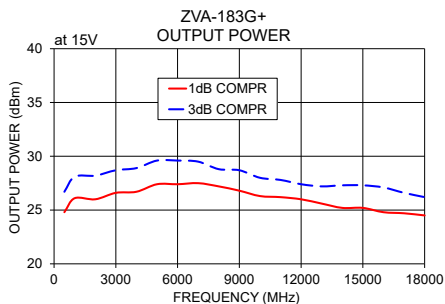
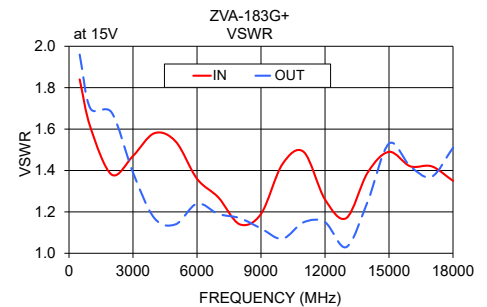
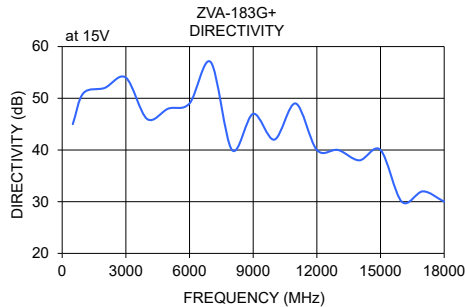
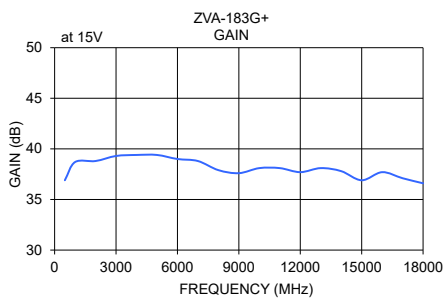

NOTES

- A. Performance and quality attributes and conditions not expressly stated in this specification document are intended to be excluded and do not form a part of this specification document.
- B. Electrical specifications and performance data contained in this specification document are based on Mini-Circuit's applicable established test performance criteria and measurement instructions.
- C. The parts covered by this specification document are subject to Mini-Circuits standard limited warranty and terms and conditions (collectively, "Standard Terms"); Purchasers of this part are entitled to the rights and benefits contained there in. For a full statement of the standard. Terms and the exclusive rights and remedies thereunder, please visit Mini-Circuits' website at www.minicircuits.com/MCLStore/terms.jsp



Wideband Amplifier

ZVA-183G+

Typical Performance Data

Frequency (MHz)	Gain (dB) 15V	Directivity (dB) 15V	VSWR In (:1) 15V	VSWR Out (:1) 15V	Noise Figure (dB) 15V	Pout at 1dB Compression (dBm) 15V	Pout at 3dB Compression (dBm) 15V	Output IP3 (dBm) 15V
500	36.90	45.00	1.84	1.96	3.73	24.80	26.70	35.10
1000	38.70	51.00	1.61	1.70	2.67	26.10	28.10	36.60
2000	38.80	52.00	1.38	1.68	2.39	26.00	28.20	36.80
3000	39.30	54.00	1.47	1.39	2.37	26.60	28.70	37.10
4000	39.40	46.00	1.58	1.17	2.25	26.70	28.90	37.10
5000	39.40	48.00	1.54	1.14	2.25	27.40	29.60	37.20
6000	39.00	49.00	1.36	1.24	2.04	27.40	29.60	37.20
7000	38.80	57.00	1.27	1.19	2.06	27.50	29.50	37.20
8000	37.90	40.00	1.14	1.17	1.98	27.20	28.80	37.20
9000	37.60	47.00	1.19	1.12	2.09	26.80	28.70	36.80
10000	38.10	42.00	1.43	1.07	2.23	26.30	28.00	35.80
11000	38.10	49.00	1.49	1.15	2.21	26.20	27.80	35.60
12000	37.70	40.00	1.26	1.15	2.29	26.00	27.40	35.80
13000	38.10	40.00	1.17	1.03	2.34	25.60	27.20	35.60
14000	37.80	38.00	1.39	1.25	2.49	25.20	27.30	35.10
15000	36.90	40.00	1.49	1.53	2.59	25.20	27.30	34.70
16000	37.70	30.00	1.42	1.42	2.65	24.80	27.10	33.40
17000	37.10	32.00	1.42	1.37	2.70	24.70	26.60	33.20
18000	36.60	30.00	1.35	1.51	3.22	24.50	26.20	33.90



P.O. Box 350166, Brooklyn, New York 11235-0003 (718) 934-4500 • Fax (718) 332-4661 For detailed performance specs & shopping online see Mini-Circuits web site
 The Design Engineers Search Engine Provides ACTUAL Data Instantly From MINI-CIRCUITS At: www.minicircuits.com

IF/RF MICROWAVE COMPONENTS

REV. OR
ZVA-183G+
8/4/2017
Page 1 of 1

Typical Performance Curves

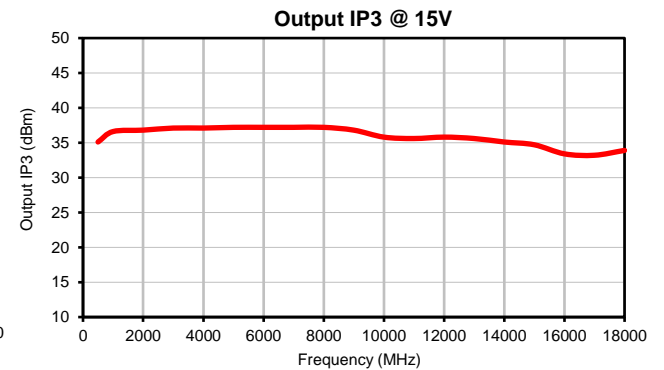
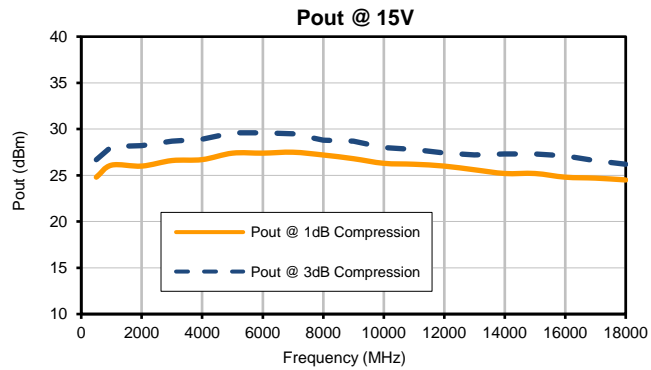
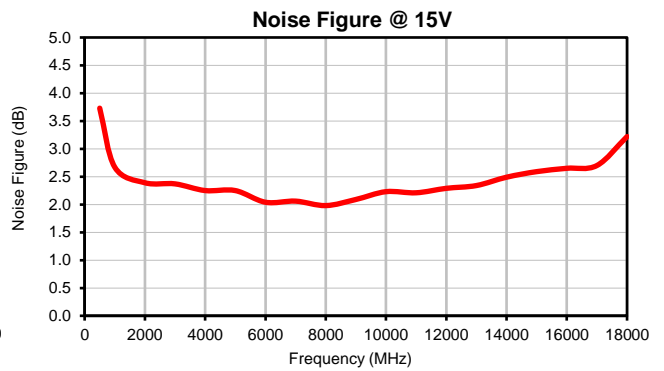
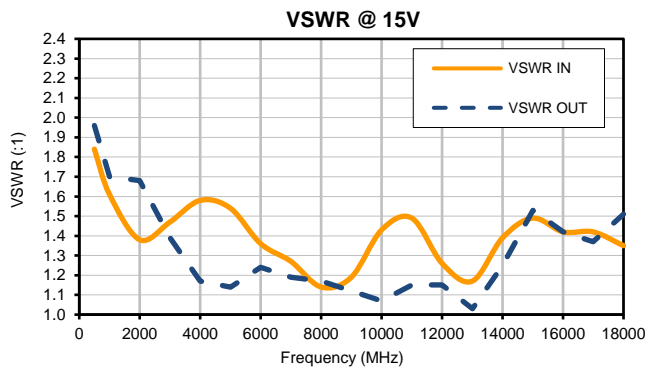
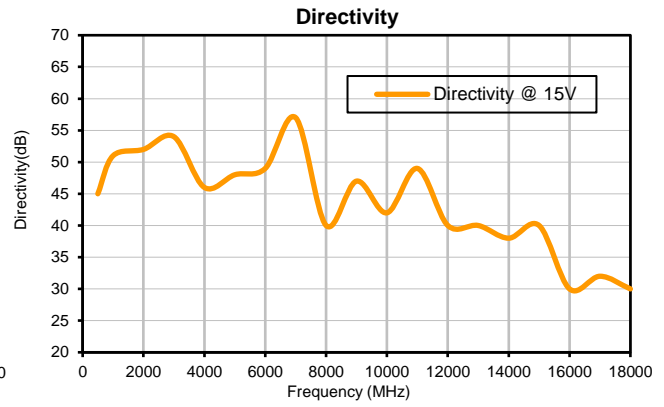
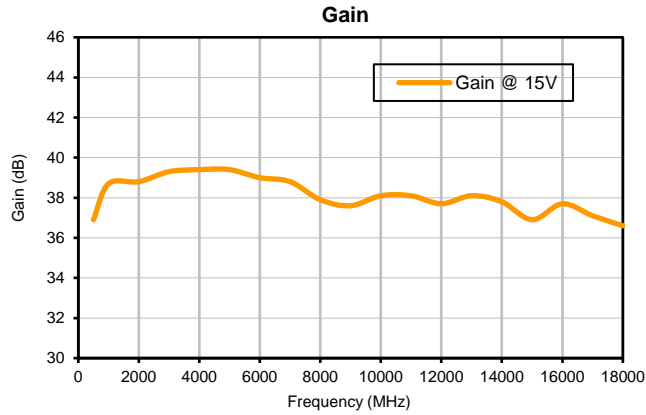

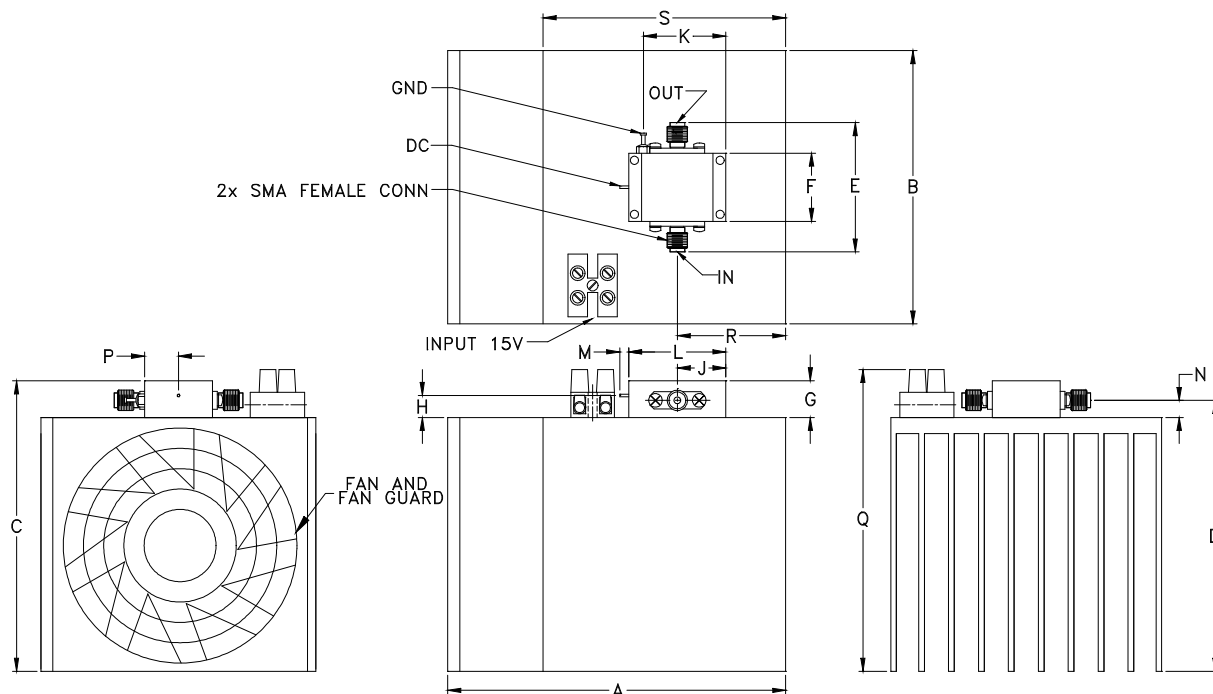

MOUNTING INFORMATION FOR MODELS WITHOUT HEATSINK

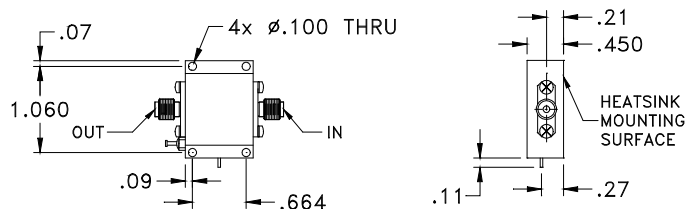

CASE#	A	B	C	D	E	F	G	H	J	K	L	M	N
CP1755	4.18 (106.17)	3.36 (85.34)	3.57 (90.69)	3.33 (84.58)	1.59 (40.39)	.840 (21.34)	.45 (11.43)	.27 (6.86)	.600 (15.24)	1.02 (25.91)	1.200 (30.48)	.11 (2.79)	.21 (5.33)

CASE#	P	Q	R	S	T	WT. GRAMS	WT. WITHOUT HEATSINK GRAMS
CP1755	.420 (10.67)	3.71 (94.23)	1.34 (34.04)	3.00 (85.34)	-- --	480	18.2

Dimensions are in inches (mm). Tolerances: 2 Pl. $\pm .03$; 3 Pl. $\pm .015$

Notes:

1. Case material: Aluminum alloy.
2. Case finish: Electroless Nickel.
3. Heat sink finish: Black anodize if supplied with heat sink.



P.O. Box 350166, Brooklyn, New York 11235-0003 (718) 934-4500 Fax (718) 332-4661 For detailed performance specs & shopping online see Mini-Circuits web site



The Design Engineers Search Engine Provides ACTUAL Data Instantly From MINI-CIRCUITS At: www.minicircuits.com

RF/IF MICROWAVE COMPONENTS

All Mini-Circuits products are manufactured under exacting quality assurance and control standards, and are capable of meeting published specifications after being subjected to any or all of the following physical and environmental test.

Specification	Test/Inspection Condition	Reference/Spec
Operating Temperature	-55° to 85°C base plate temp	Individual Model Data Sheet
Storage Temperature	-65° to 150°C	Individual Model Data Sheet
Thermal Shock	-55° to 100°C, 100 cycles	MIL-STD-202, Method 107
Vibration (High Frequency)	Category 24, Exposure level figures 514C-17 General use, random, 20-2000Hz, 1 hr per axis	MIL-STD-810, Method 514.5
Mechanical Shock	40Gs, 11ms, 18 shocks: 3 each direction), each axis	MIL-STD-810, Method 516-5-II