



COAXIAL WIDEBAND

Medium Power Amplifier **ZVA-183WA-S+** **ZVA-183WAX-S+**

Mini-Circuits

50Ω 100 MHz to 18 GHz SMA Female

THE BIG DEAL

- Wideband 100 MHz to 18 GHz
- 30dBm Psat typical
- Excellent Gain Flatness, ±1.5dB typical
- Low Noise Figure, 4 dB typical
- Over-Voltage & Reverse Voltage Protection
- Single Supply Voltage of +12 VDC

APPLICATIONS

- Lab use
- Wideband Test and Measurement
- 5G Sub-6 GHz
- Driver Amplifier
- Aerospace and Defense
- Radios, Radars and Satellite Systems
- Industrial, Scientific and Medical

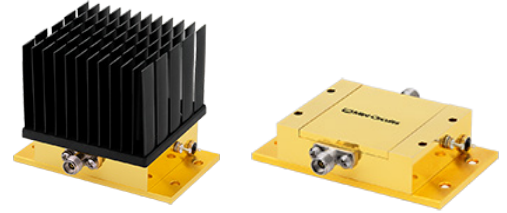

Generic photo used for illustration purposes only

Model No.	ZVA-183WA-S+	ZVA-183WAX-S+
Option	With heatsink	Without heatsink
Case Style	AV2554-3	
Connector	SMA Female	

+RoHS Compliant

The +Suffix identifies RoHS Compliance.
See our website for methodologies and qualifications

PRODUCT OVERVIEW

Mini-Circuits' ZVA-183WA(X)-S+ is a coaxial, wideband RF amplifier capable of operating from 100 MHz to 18 GHz. The design can deliver output power of +30 dBm typical at saturation and +27 dBm typical at 1dB compression, making it an ideal choice for applications requiring a wideband driver amplifier. With a low noise figure of 4 dB typical across a majority of the band, it can be used in test setups that require higher dynamic range. The amplifier incorporates several DC-protection features such as over-voltage, reverse voltage, and in-rush current, that protect the amplifier from damage if mishandled during operation.

KEY FEATURES

Features	Advantages
Ultra-wideband, 100 MHz to 18 GHz	Enables a single amplifier to be used in a wide range of applications.
Low noise and high IP3: <ul style="list-style-type: none"> • NF, 4 dB typical • IP3, +36 dBm typical 	The combination of low noise and high IP3 makes the ZVA-183WA(X)-S+ ideal for use in receiver front ends (RFE) as it gives the user the advantages of sensitivity and two-tone IM performance at both ends of the dynamic range.

**ELECTRICAL SPECIFICATION AT 25 °C (AMBIENT), VDD = 12V TYPICAL**

Parameter	Condition (MHz)	ZVA-183WA-S+ ZVA-183WAX-S+			Units
		Min.	Typical	Max.	
Frequency Range	-	100	-	18000	MHz
Gain	100 – 6000	22	25	-	dB
	6000 – 18000	20	24	-	
Output Power at 1dB compression	100 – 1000	23.5	27	-	dBm
	1000 – 6000	27	29	-	
	6000 – 18000	25	27.5	-	
Noise Figure	500 – 18000	-	4	-	dB
Output IP3 (output power = 10 dBm/tone)	100 – 6000	-	38	-	dBm
	6000 – 18000	-	36	-	
Input VSWR	100– 18000	-	1.3	-	:1
Output VSWR ¹	100 – 18000	-	1.5	-	:1
DC Supply Voltage	-	11	12	13	V
Supply Current ² (at 12V DC)	-	-	550	950	mA

1. Open and short-circuit loads are not recommended at the amplifier output. Ensure proper 50-ohm load before turning the amplifier "ON"

2. Maximum Supply Current is specified at Saturated Output Power.

MAXIMUM RATINGS⁵

Parameter	Ratings
Operating Temperature (Ambient)	-40° C to +50° C
Operating Temperature (Baseplate)	-40° C to +75° C
Storage Temperature	-55° C to +125° C
Total Power Dissipation ³	11 W
RF Input Power ⁴ (CW), VDD=12V	+15 dBm
DC Voltage	+14 V

3. Total Power Dissipation is specified at Saturated Output Power.

4. Specified under matched load to 50 ohms.

5. Continuous operation is not recommended at these extremes. Permanent damage may occur if any of these limits are exceeded.

DETERMINING MAXIMUM THERMAL RESISTANCE OF USERS' EXTERNAL HEAT SINK

$\text{MAXIMUM THERMAL RESISTANCE} = \frac{\text{MAXIMUM OPERATING CASE TEMP} - \text{MAXIMUM USER AMBIENT TEMP}}{\text{POWER DISSIPATION}}$	
Example:	MAXIMUM OPERATING CASE TEMP = 50 °C (CHECK MAXIMUM RATINGS TABLE FOR THIS VALUE) MAXIMUM USER AMBIENT TEMP = 30 °C (USER DEFINED) POWER DISSIPATION = 10 WATTS (CHECK MAXIMUM RATINGS TABLE FOR THIS VALUE) THEN MAXIMUM ALLOWABLE THERMAL RESISTANCE = 2 °C/W



COAXIAL WIDEBAND

Medium Power Amplifier

ZVA-183WA-S+ ZVA-183WAX-S+

Mini-Circuits

50Ω 100 MHz to 18 GHz SMA Female

COAXIAL CONNECTIONS

Input	SMA Female
Output	SMA Female

OUTLINE DRAWING

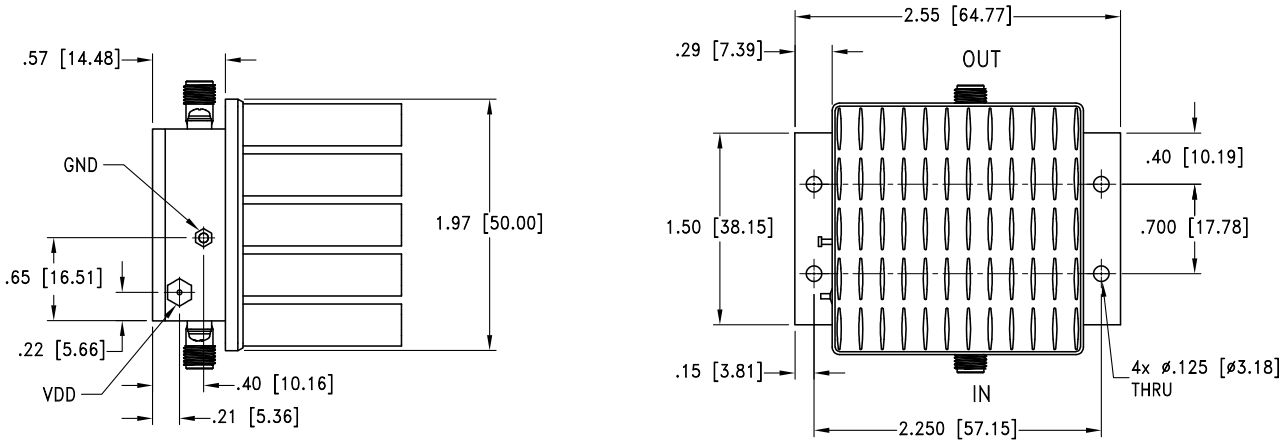

MOUNTING INFORMATION OF MODEL WITHOUT HEATSINK

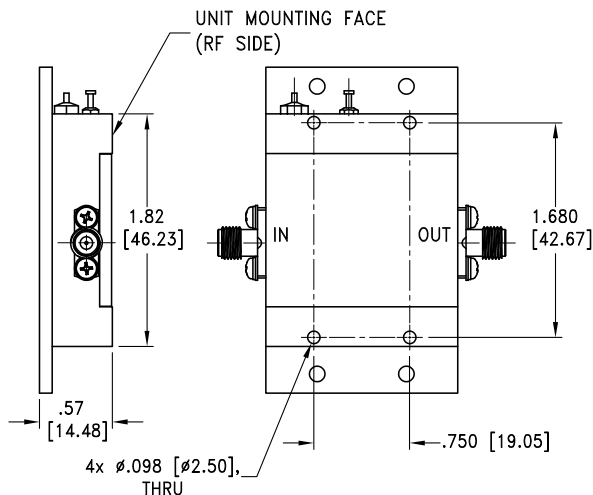

Weight without heatsink: 345 grams;

Weight: 455 grams;

Dimensions are in [mm] Tolerances: 2 Pl.±.03; 3 Pl. ±.015

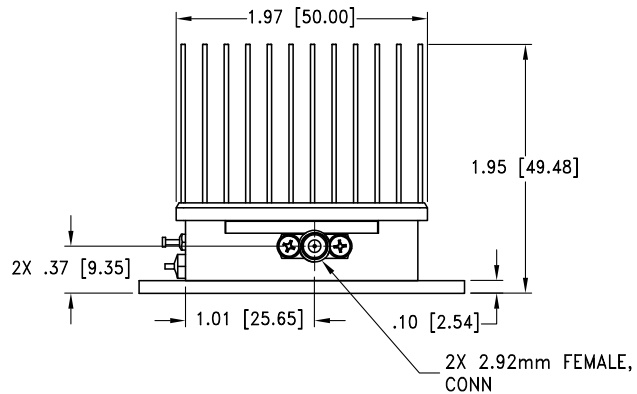



TYPICAL PERFORMANCE DATA/GRAPHS

Frequency (MHz)	Gain (dB)	Directivity (dB)	VSWR (:1) 12V		Pout @ 1 dB Compression (dBm)	Pout @ Saturation (dBm)	Output IP3 (dBm)	Noise Figure (dB)
	12V	12V	IN	OUT	12V	12V	12V	12V
100	25.8	53.7	1.2	1.4	24.8	30.6	35.1	14.7
1000	25.5	88.5	1.2	1.7	28.7	31.3	38.7	5.3
2000	24.9	83.3	1.1	1.8	29.0	31.1	39.1	5.0
3000	25.3	70.0	1.1	1.5	29.3	31.0	39.1	4.4
4000	25.2	68.1	1.0	1.2	29.3	31.1	42.8	3.9
5000	25.2	63.7	1.1	1.2	29.6	31.4	39.4	3.2
6000	25.0	80.7	1.2	1.2	29.4	31.4	38.4	2.9
7000	24.4	63.1	1.2	1.0	28.6	30.2	37.1	2.8
8000	23.9	54.9	1.3	1.2	27.8	28.9	37.0	2.6
9000	23.8	64.6	1.6	1.2	27.4	28.6	36.0	2.8
10000	23.8	57.3	1.6	1.2	27.3	29.0	35.6	2.8
11000	23.4	59.2	1.4	1.3	26.8	28.4	35.3	3.0
12000	23.9	54.3	1.4	1.2	27.0	29.0	35.7	3.1
13000	24.8	47.9	1.4	1.1	27.1	29.6	35.5	3.3
14000	25.0	45.4	1.4	1.4	27.1	30.0	36.7	3.3
15000	24.9	44.8	1.4	1.3	27.1	30.0	36.4	3.5
16000	24.8	40.0	1.4	1.0	27.3	30.2	35.2	3.7
17000	24.2	40.1	1.3	1.3	27.9	29.9	35.5	3.8
18000	24.1	39.0	1.1	1.6	27.2	29.2	33.6	4.2

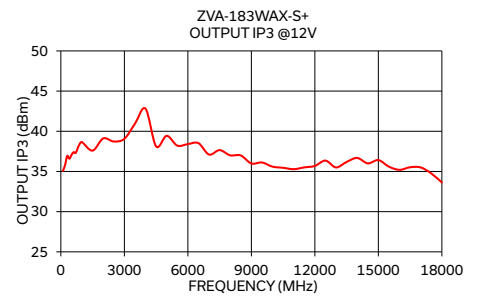
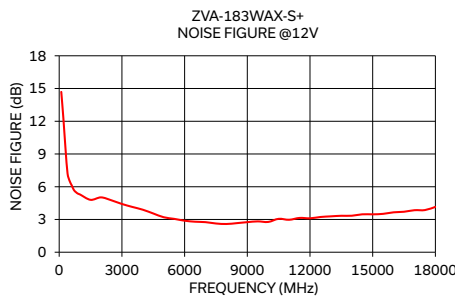
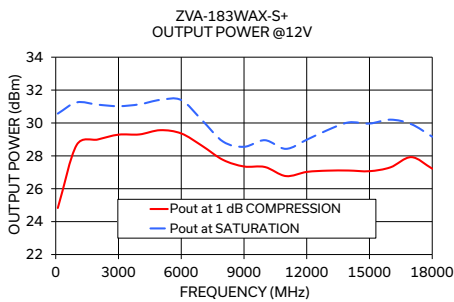
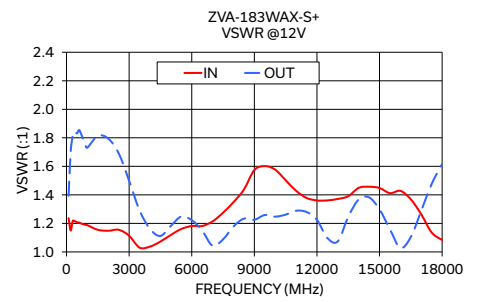
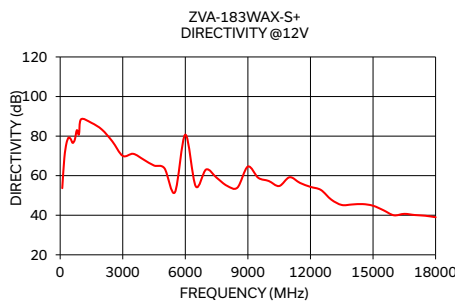
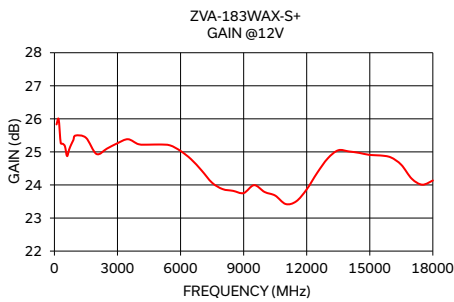

- NOTES**
- A. Performance and quality attributes and conditions not expressly stated in this specification document are intended to be excluded and do not form a part of this specification document.
 - B. Electrical specifications and performance data contained in this specification document are based on Mini-Circuit's applicable established test performance criteria and measurement instructions.
 - C. The parts covered by this specification document are subject to Mini-Circuits standard limited warranty and terms and conditions (collectively, "Standard Terms"); Purchasers of this part are entitled to the rights and benefits contained therein. For a full statement of the standard terms and the exclusive rights and remedies thereunder, please visit Mini-Circuits' website at www.minicircuits.com/terms/viewterm.html

Coaxial Amplifier

ZVA-183WAX-S+

Typical Performance Data

FREQUENCY (MHz)	GAIN (dB) 12V	DIRECTIVITY (dB) 12V	VSWR (:1)		NOISE FIGURE (dB) 12V	Pout @ 1 dB COMPRESSION (dBm) 12V	OUTPUT IP3 (dBm) 12V	FREQUENCY (MHz)	Pout at SATURATION (dBm) 12V
			IN 12V	OUT 12V					
100	25.83	53.68	1.24	1.39	14.69	24.83	35.07	100.00	30.57
200	25.99	68.94	1.15	1.70	12.29	26.84	35.80	1000.00	31.25
300	25.27	76.29	1.22	1.82	9.55	27.73	36.94	2000.00	31.11
400	25.25	79.20	1.22	1.84	7.20	28.16	36.59	3000.00	31.02
500	25.17	78.59	1.21	1.83	6.53	28.18	37.04	4000.00	31.13
600	24.87	76.55	1.21	1.85	6.13	28.11	37.40	5000.00	31.40
700	25.07	78.11	1.20	1.83	5.71	28.40	37.30	6000.00	31.39
800	25.23	82.97	1.19	1.79	5.51	28.44	37.92	7000.00	30.16
900	25.36	80.83	1.19	1.76	5.36	28.52	38.47	8000.00	28.87
1000	25.49	88.48	1.19	1.73	5.29	28.66	38.65	9000.00	28.55
1500	25.43	86.69	1.15	1.81	4.80	28.95	37.59	10000.00	28.95
2000	24.94	83.30	1.15	1.79	5.02	28.99	39.11	11000.00	28.43
2500	25.10	77.34	1.16	1.69	4.76	29.25	38.73	12000.00	28.98
3000	25.26	70.00	1.11	1.50	4.42	29.29	39.06	13000.00	29.57
3500	25.38	71.04	1.03	1.29	4.15	29.40	40.94	14000.00	30.03
4000	25.23	68.13	1.04	1.16	3.89	29.30	42.82	15000.00	29.96
4500	25.22	65.12	1.07	1.11	3.55	29.43	38.12	16000.00	30.20
5000	25.22	63.75	1.12	1.18	3.21	29.56	39.44	17000.00	29.93
5500	25.20	51.59	1.16	1.25	3.06	29.42	38.22	18000.00	29.17
6000	25.03	80.72	1.18	1.22	2.89	29.36	38.41		
6500	24.78	54.62	1.18	1.15	2.80	29.24	38.52		
7000	24.44	63.14	1.21	1.04	2.76	28.61	37.10		
7500	24.07	58.97	1.27	1.09	2.63	28.22	37.65		
8000	23.88	54.88	1.35	1.18	2.59	27.75	37.01		
8500	23.82	53.98	1.44	1.23	2.66	27.49	36.99		
9000	23.76	64.59	1.57	1.23	2.75	27.35	35.99		
9500	23.99	58.90	1.60	1.26	2.82	27.68	36.12		
10000	23.79	57.31	1.58	1.25	2.77	27.32	35.60		
10500	23.68	54.76	1.50	1.26	3.06	26.95	35.46		
11000	23.42	59.20	1.43	1.29	2.97	26.77	35.28		
11500	23.50	56.33	1.38	1.28	3.14	26.90	35.51		
12000	23.87	54.34	1.36	1.22	3.11	27.02	35.69		
12500	24.37	52.79	1.36	1.10	3.23	27.01	36.35		
13000	24.80	47.88	1.37	1.07	3.29	27.10	35.50		
13500	25.05	45.19	1.39	1.25	3.34	27.23	36.18		
14000	25.01	45.44	1.45	1.37	3.34	27.11	36.68		
14500	24.97	45.64	1.46	1.38	3.47	27.05	36.01		
15000	24.91	44.81	1.45	1.30	3.47	27.07	36.42		
15500	24.89	42.52	1.41	1.16	3.52	27.23	35.60		
16000	24.83	39.98	1.43	1.03	3.66	27.30	35.20		
16500	24.61	40.69	1.37	1.10	3.71	27.73	35.53		
17000	24.19	40.11	1.26	1.29	3.85	27.92	35.50		
17500	24.01	39.76	1.14	1.48	3.86	27.73	34.75		
18000	24.14	39.00	1.08	1.62	4.15	27.22	33.63		

Coaxial Amplifier

ZVA-183WAX-S+

Typical Performance Curves

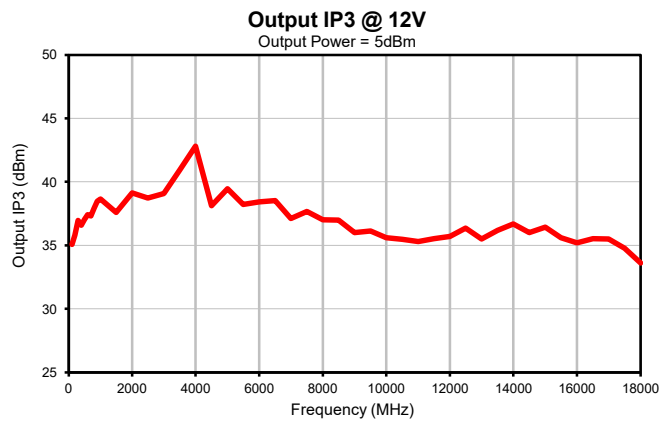
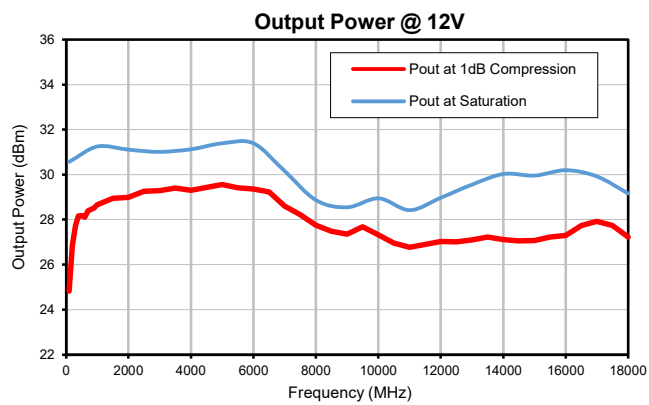
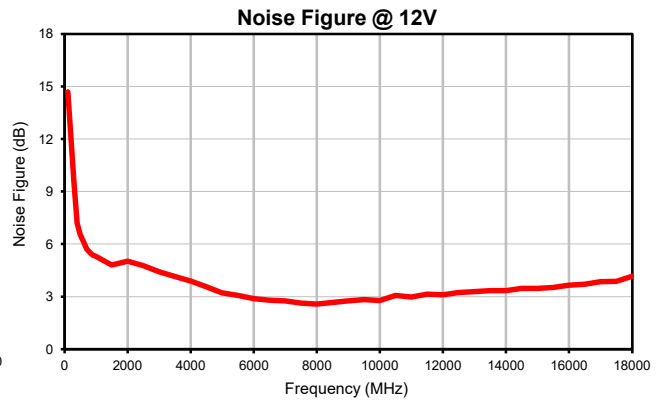
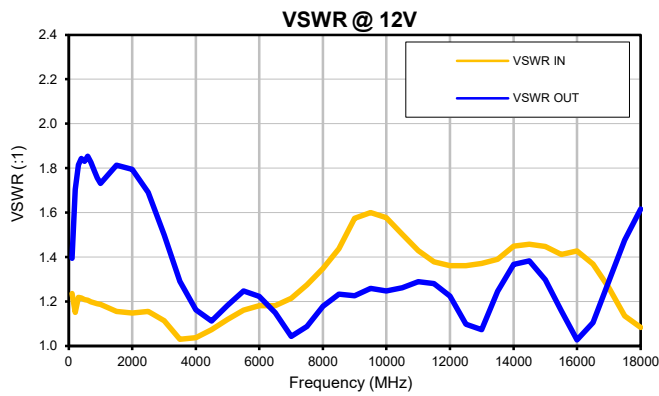
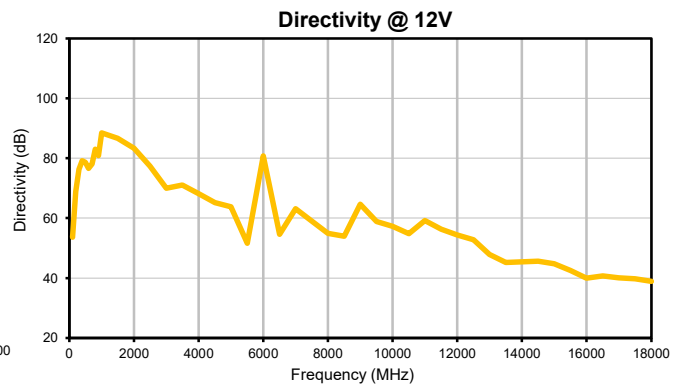
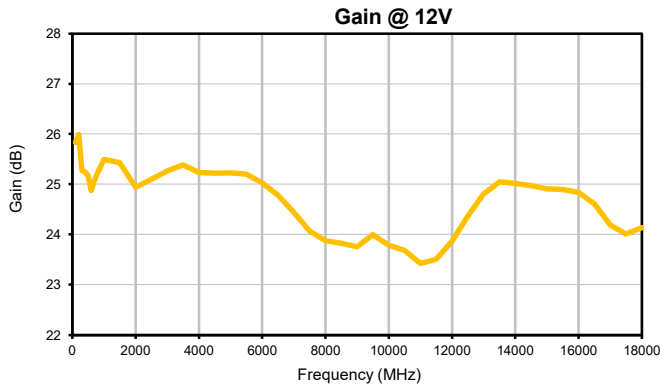

Outline Dimensions

AV2554-3

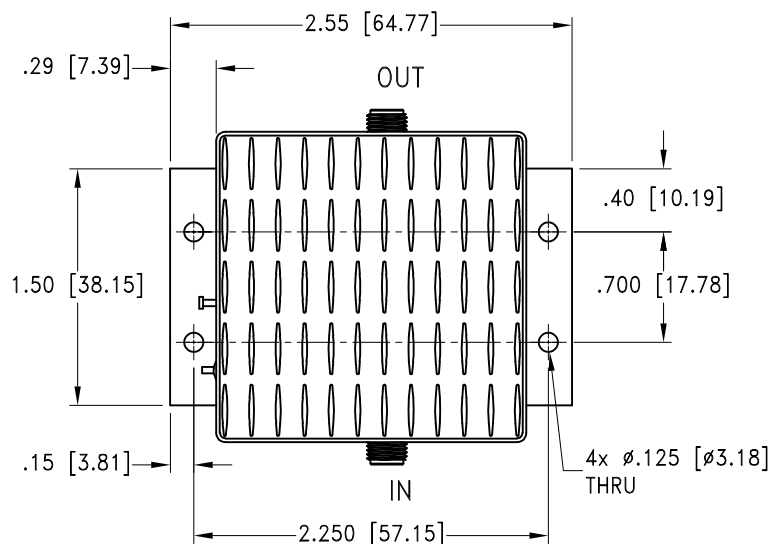
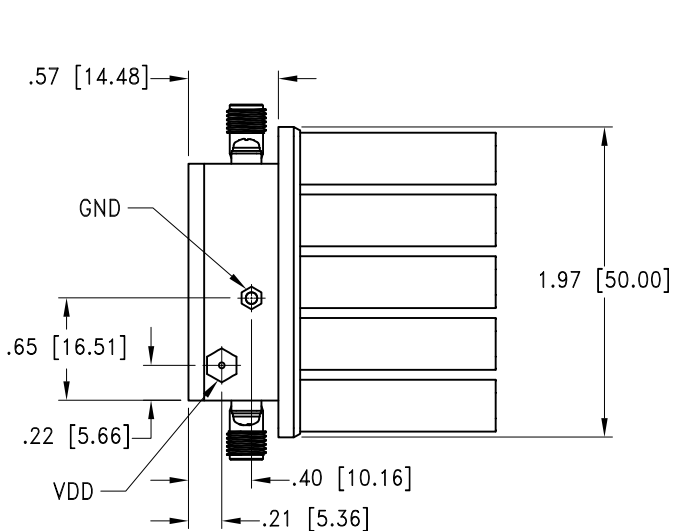

MOUNTING INFORMATION OF MODEL WITHOUT HEATSINK

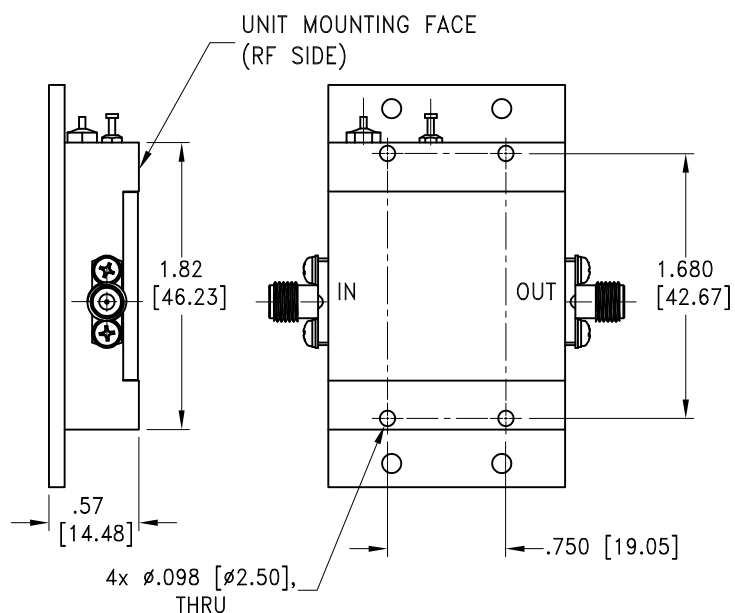

Weight without heatsink: 345 grams;

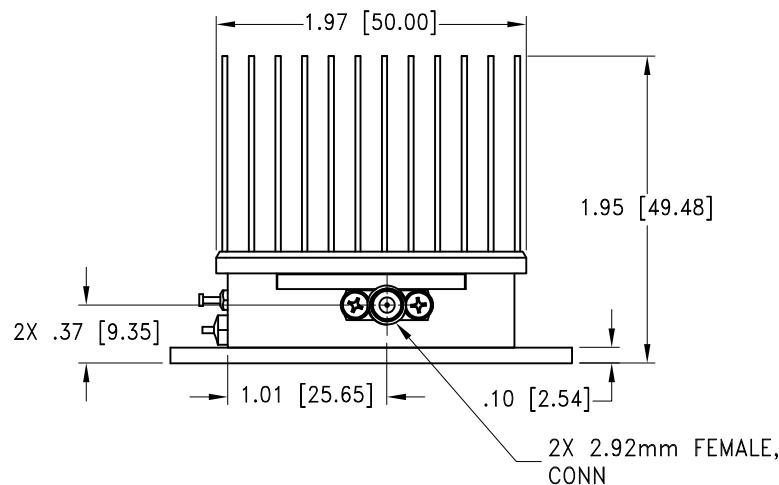

Weight: 455 grams;

Dimensions are in inches (mm). Tolerances: 2 Pl. \pm .03; 3 Pl. \pm .015

Notes:

1. Case material: Brass
2. Case finish: Gold plate.
3. Heat sink finish: Black anodize.

Mini-Circuits
ISO 9001 ISO 14001 CERTIFIED

ALL NEW
minicircuits.com

P.O. Box 350166, Brooklyn, New York 11235-0003 (718) 934-4500 Fax (718) 332-4661 For detailed performance specs & shopping online see Mini-Circuits web site



The Design Engineers Search Engine Provides ACTUAL Data Instantly From MINI-CIRCUITS At: www.minicircuits.com

RF/IF MICROWAVE COMPONENTS

All Mini-Circuits products are manufactured under exacting quality assurance and control standards, and are capable of meeting published specifications after being subjected to any or all of the following physical and environmental test.

Specification	Test/Inspection Condition	Reference/Spec
Operating Temperature	-55° to 85°C base plate temp	Individual Model Data Sheet
Storage Temperature	-65° to 150°C	Individual Model Data Sheet
Thermal Shock	-55° to 100°C, 100 cycles	MIL-STD-202, Method 107
Vibration (High Frequency)	Category 24, Exposure level figures 514C-17 General use, random, 20-2000Hz, 1 hr per axis	MIL-STD-810, Method 514.5
Mechanical Shock	40Gs, 11ms, 18 shocks: 3 each direction), each axis	MIL-STD-810, Method 516-5-II