



CAVITY COAXIAL

# Bandpass Filter

## ZVBP500W-2450N+

50Ω 2400 to 2500 MHz N Female

### KEY FEATURES

- Low Insertion Loss, 0.12 dB Typ.
- Good Return Loss, 23 dB Typ.
- High Rejection, 60 dB Typ.
- Stopband up to 5000 MHz
- High Power Handling: 500 Watts



Generic photo used for illustration purposes only

### APPLICATIONS

- Industrial
- Telecom
- Test and Measurement
- Aerospace and defense

### PRODUCT OVERVIEW

Mini-Circuits' ZVBP500W-2450N+ is a coaxial cavity filter designed by implementing resonant structures with very high Q and are ideal for narrow-band, high-selectivity applications. Mini-Circuits' coaxial cavity filters feature a special protective assembly to prevent accidental de-tuning that would otherwise require expensive replacement or return to factory for re-tuning. Precise machining allows realization of cavity filters with small form factors for applications where size is critical.

### FUNCTIONAL DIAGRAM

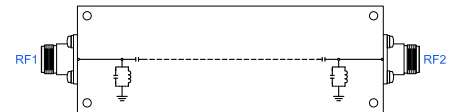

### ELECTRICAL SPECIFICATIONS AT +25°C

Parameter		F#	Frequency (MHz)	Min.	Typ.	Max.	Units
Passband	Center Frequency	Fc	—	—	2450	—	MHz
	Insertion Loss	F1-F2	2400 - 2500	—	0.12	0.4	dB
	Return Loss	F1-F2	2400 - 2500	16	23	—	dB
Stopband, Lower	Rejection	DC-F3	DC - 2050	52	57	—	dB
Stopband, Upper	Rejection	F4-F5	2850 - 5000	54	60	—	dB

### ABSOLUTE MAXIMUM RATINGS<sup>1,2</sup>

Parameter	Ratings
Operating Temperature	-40°C to +85°C
Storage Temperature	-55°C to +100°C
Input Power <sup>3</sup>	500 W max. at +25°C

1. Permanent damage may occur if any of these limits are exceeded.
2. Input and output ports are DC short to ground.
3. Power rating applies only to signals within the passband.

### TYPICAL FREQUENCY RESPONSE

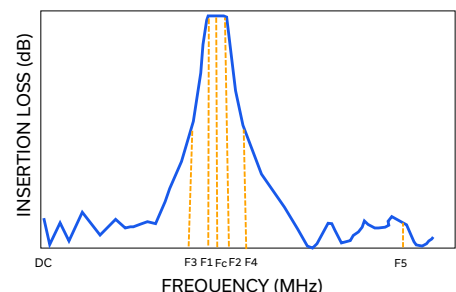



CAVITY COAXIAL

# Bandpass Filter

## ZVBP500W-2450N+

Mini-Circuits

50Ω 2400 to 2500 MHz N Female

### TYPICAL PERFORMANCE GRAPHS

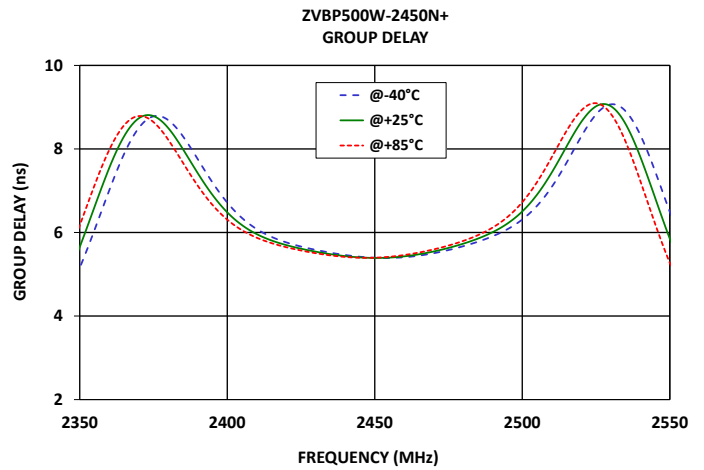
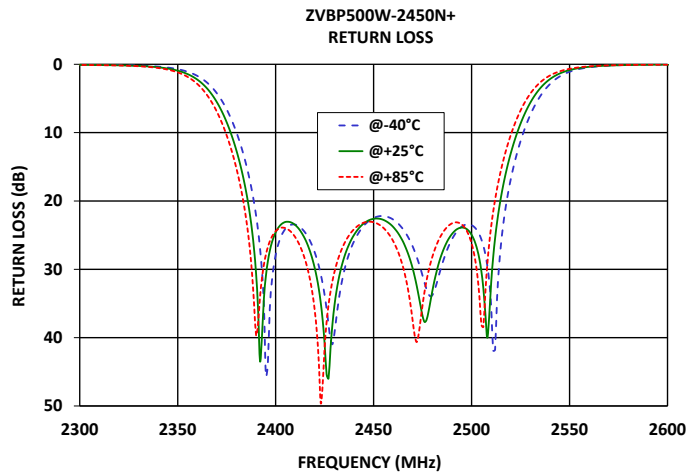
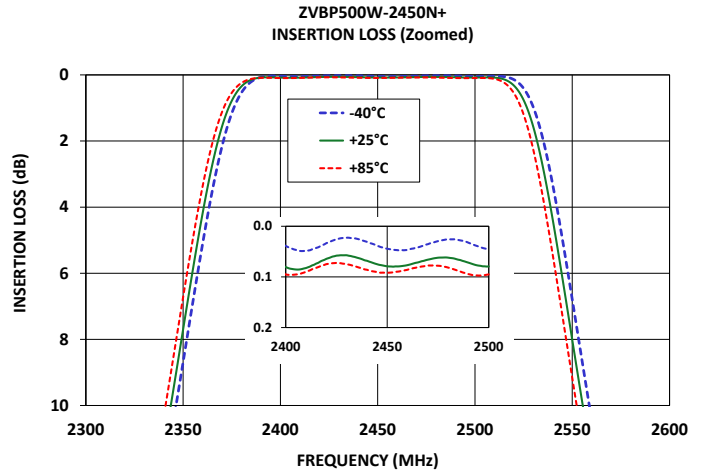
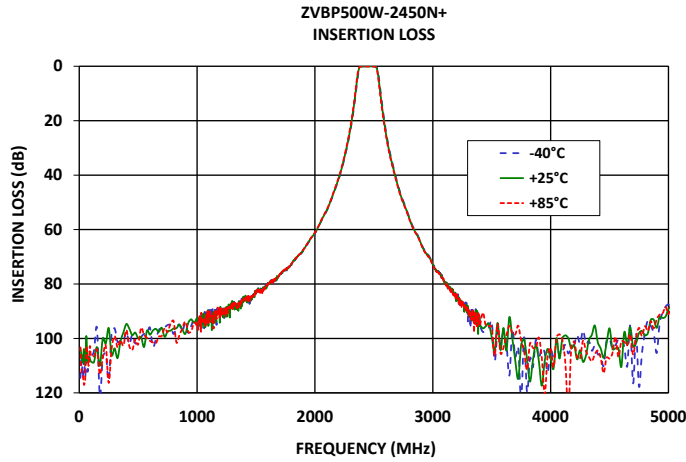



CAVITY COAXIAL

# Bandpass Filter

## ZVBP500W-2450N+

Mini-Circuits

50Ω 2400 to 2500 MHz N Female

### CONNECTOR DESCRIPTION

Function	Connector
RF1 <sup>4</sup>	N Female
RF2 <sup>4</sup>	N Female

4. This filter is bi-directional RF1 and RF2 ports may be interchanged, see S-Parameters for actual performance.

### CASE STYLE DRAWING

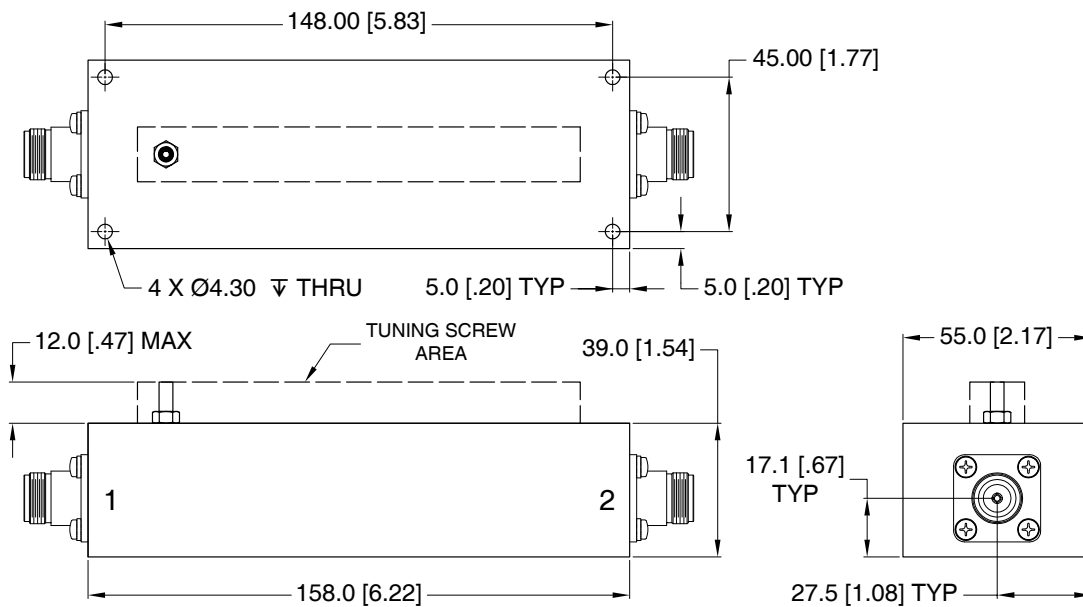

Dimensions are in mm (inches). Tolerances: 1 Pl.  $\pm 1.5$  (0.06); 2 Pl.  $\pm 0.38$  (0.015)

**PRODUCT MARKING\*:** ZVBP500W-2450N+

\*Marking may contain other features or characters for internal lot control.



CAVITY COAXIAL

# Bandpass Filter

## ZVBP500W-2450N+

Mini-Circuits

50Ω 2400 to 2500 MHz N Female

ADDITIONAL INFORMATION IS AVAILABLE ON OUR DASHBOARD

[CLICK HERE](#)

Performance Data & Graphs	<p>Data</p> <p>Graphs</p> <p>S-Parameter (S2P Files) Data Set (.zip file)</p>
Case Style	BBD3778
RoHS Status	Compliant
Environmental Ratings	ENV77T1

### NOTES

- A. Performance and quality attributes and conditions not expressly stated in this specification document are intended to be excluded and do not form a part of this specification document.
- B. Electrical specifications and performance data contained in this specification document are based on Mini-Circuits' applicable established test performance criteria and measurement instructions.
- C. The parts covered by this specification document are subject to Mini-Circuits' standard limited warranty and terms and conditions (collectively, "Standard Terms"); Purchasers of this part are entitled to the rights and benefits contained therein. For a full statement of the standard terms and the exclusive rights and remedies thereunder, please visit Mini-Circuits' website at [www.minicircuits.com/terms/viewterm.html](http://www.minicircuits.com/terms/viewterm.html)



# Cavity Band Pass Filter

# ZVBP500W-2450N+

## Typical Performance Data

FREQ.	INSERTION LOSS			INPUT RETURN LOSS			OUTPUT RETURN LOSS		
	(dB)			(dB)			(dB)		
	@-40°C	@+25°C	@+85°C	@-40°C	@+25°C	@+85°C	@-40°C	@+25°C	@+85°C
10	114.52	103.69	103.29	0.00	0.01	0.00	0.00	0.00	0.01
100	106.91	108.52	106.35	0.01	0.02	0.02	0.01	0.02	0.02
300	96.22	103.63	99.11	0.03	0.04	0.04	0.03	0.04	0.04
400	97.32	94.69	96.88	0.04	0.04	0.04	0.03	0.04	0.04
500	101.19	99.90	102.23	0.04	0.05	0.05	0.03	0.04	0.04
600	96.03	98.63	100.89	0.04	0.04	0.04	0.03	0.04	0.05
700	95.73	96.08	99.11	0.03	0.04	0.04	0.02	0.04	0.04
800	98.38	96.34	93.56	0.03	0.04	0.04	0.02	0.04	0.04
900	94.16	98.35	93.82	0.02	0.04	0.04	0.01	0.03	0.04
1000	93.55	92.53	95.68	0.02	0.03	0.03	0.01	0.03	0.03
1100	90.15	91.57	90.39	0.01	0.03	0.03	0.00	0.02	0.03
1200	90.17	90.26	92.11	0.01	0.02	0.02	0.01	0.02	0.03
1300	87.14	88.20	88.02	0.00	0.02	0.02	0.01	0.01	0.02
1400	84.93	84.67	85.64	0.00	0.02	0.02	0.01	0.01	0.02
1500	82.63	82.38	83.65	0.01	0.01	0.01	0.02	0.01	0.02
1600	79.77	79.87	79.52	0.01	0.01	0.01	0.02	0.01	0.02
1700	76.97	76.75	77.03	0.01	0.01	0.01	0.02	0.01	0.02
1800	72.69	72.54	72.79	0.01	0.01	0.01	0.02	0.01	0.02
1900	67.75	67.58	67.44	0.01	0.01	0.02	0.02	0.01	0.02
2000	61.45	61.24	61.15	0.00	0.02	0.02	0.01	0.02	0.03
2050	57.19	57.08	56.88	0.00	0.02	0.02	0.01	0.02	0.03
2100	53.14	52.93	52.69	0.01	0.02	0.03	0.00	0.03	0.04
2200	41.73	41.42	41.04	0.02	0.04	0.04	0.01	0.04	0.05
2260	32.10	31.66	31.14	0.03	0.05	0.06	0.02	0.05	0.07
2280	28.17	27.64	27.04	0.04	0.06	0.07	0.03	0.06	0.08
2310	21.28	20.58	19.82	0.08	0.11	0.12	0.07	0.11	0.14
2340	12.24	11.31	10.35	0.34	0.44	0.54	0.32	0.44	0.55
2362	4.45	3.57	2.81	2.04	2.69	3.45	2.02	2.69	3.46
2400	0.04	0.08	0.10	27.91	24.60	24.43	28.17	24.67	24.48
2420	0.03	0.06	0.07	27.57	29.89	36.15	27.37	29.56	35.11
2440	0.03	0.07	0.09	25.91	24.97	24.13	26.02	25.03	24.23
2445	0.04	0.07	0.09	23.62	23.28	23.17	23.78	23.37	23.28
2450	0.04	0.08	0.09	22.49	22.61	23.12	22.68	22.73	23.23
2460	0.05	0.08	0.09	22.73	23.81	25.89	23.04	24.02	26.10
2470	0.04	0.07	0.08	26.70	29.95	37.68	27.66	30.97	41.15
2480	0.03	0.06	0.08	33.78	33.14	28.15	39.01	34.30	28.16
2490	0.03	0.07	0.09	25.60	24.83	23.28	25.70	24.82	23.22
2500	0.05	0.08	0.10	23.54	24.96	26.22	23.46	24.90	26.15
2536	2.21	3.11	4.06	4.27	3.19	2.41	4.23	3.17	2.40
2555	8.63	9.86	10.99	0.68	0.55	0.44	0.66	0.53	0.44
2586	19.11	20.05	20.92	0.06	0.08	0.08	0.04	0.07	0.08
2600	23.17	24.01	24.78	0.03	0.05	0.05	0.01	0.04	0.05
2625	29.35	30.07	30.72	0.01	0.04	0.04	0.00	0.03	0.05
2700	42.87	43.35	43.78	0.01	0.04	0.04	0.00	0.03	0.05
2800	55.49	55.78	56.06	0.02	0.04	0.05	0.01	0.04	0.06
2850	60.38	60.73	61.01	0.03	0.05	0.05	0.02	0.05	0.06
2900	64.99	65.19	65.29	0.03	0.05	0.06	0.02	0.05	0.07
3000	72.47	72.72	72.98	0.04	0.06	0.06	0.03	0.06	0.07
3100	79.35	79.39	79.27	0.04	0.07	0.07	0.04	0.06	0.08
3200	84.21	85.58	84.73	0.04	0.07	0.07	0.04	0.07	0.08
3300	88.94	89.75	89.11	0.05	0.07	0.08	0.04	0.07	0.09
3400	95.07	94.86	95.48	0.05	0.07	0.08	0.04	0.08	0.09
3500	93.70	99.47	95.83	0.05	0.08	0.08	0.04	0.08	0.10
3600	97.44	96.12	103.38	0.05	0.08	0.08	0.05	0.08	0.10
3700	106.85	108.14	98.56	0.05	0.08	0.08	0.05	0.08	0.10
4000	103.66	107.42	103.44	0.04	0.07	0.08	0.03	0.08	0.10
4100	104.86	99.89	100.63	0.03	0.07	0.07	0.03	0.08	0.10
4200	102.33	102.62	101.05	0.02	0.06	0.07	0.02	0.07	0.09
4300	102.00	106.25	104.71	0.02	0.05	0.06	0.01	0.06	0.09
5000	87.51	89.14	91.08	0.04	0.01	0.00	0.05	0.00	0.03



P.O. Box 350166, Brooklyn, New York 11235-0003 (718) 934-4500 • Fax (718) 332-4661 For detailed performance specs & shopping online see Mini-Circuits web site



The Design Engineers Search Engine Provides ACTUAL Data Instantly From MINI-CIRCUITS At: [www.minicircuits.com](http://www.minicircuits.com)

IF/RF MICROWAVE COMPONENTS

REV. OR  
ZVBP500W-2450N+  
260306

## Typical Performance Data

FREQ.  (MHz)	GROUP DELAY		
	(nsec)		
	@-40°C	@+25°C	@+85°C
2400	6.72	6.48	6.31
2402	6.56	6.35	6.20
2404	6.41	6.23	6.10
2406	6.29	6.13	6.01
2408	6.18	6.04	5.94
2410	6.08	5.96	5.88
2412	6.00	5.89	5.82
2414	5.93	5.84	5.77
2416	5.87	5.78	5.72
2418	5.81	5.74	5.68
2420	5.76	5.70	5.65
2422	5.72	5.66	5.62
2424	5.68	5.63	5.58
2426	5.65	5.60	5.56
2428	5.61	5.57	5.53
2430	5.58	5.54	5.50
2432	5.56	5.52	5.48
2434	5.53	5.49	5.46
2436	5.50	5.47	5.44
2438	5.48	5.45	5.43
2440	5.46	5.43	5.42
2442	5.44	5.42	5.41
2444	5.43	5.41	5.40
2446	5.41	5.40	5.39
2448	5.40	5.39	5.39
2450	5.40	5.39	5.40
2452	5.39	5.39	5.40
2454	5.39	5.40	5.41
2456	5.39	5.40	5.43
2458	5.40	5.42	5.44
2460	5.41	5.43	5.46
2462	5.42	5.45	5.48
2464	5.44	5.47	5.51
2466	5.46	5.49	5.54
2468	5.48	5.52	5.56
2470	5.51	5.55	5.60
2480	5.67	5.73	5.80
2485	5.78	5.86	5.94
2490	5.91	6.01	6.12
2495	6.08	6.22	6.37
2500	6.31	6.51	6.73

## Typical Performance Curves

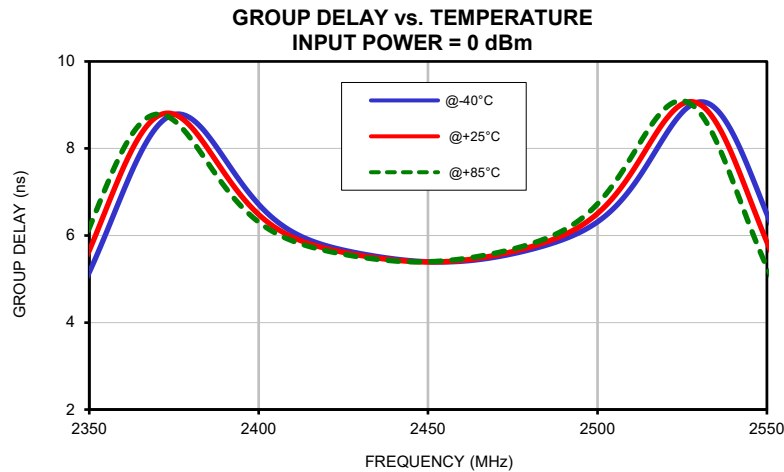
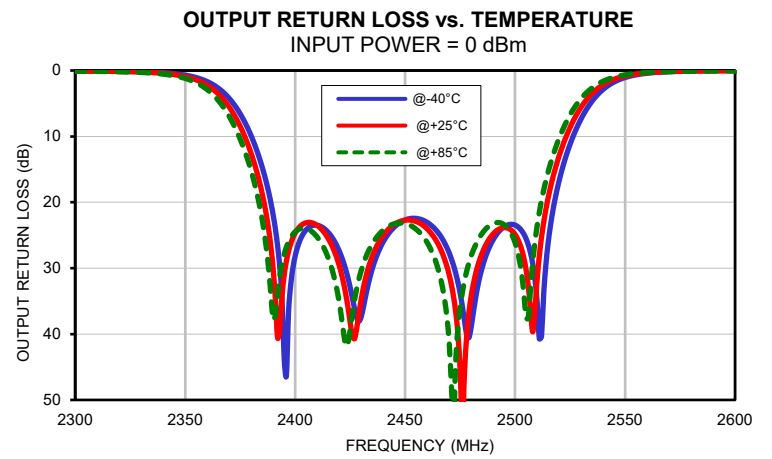
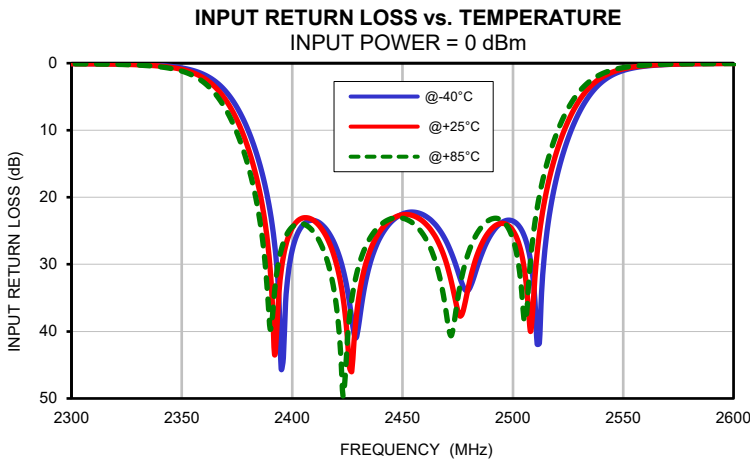
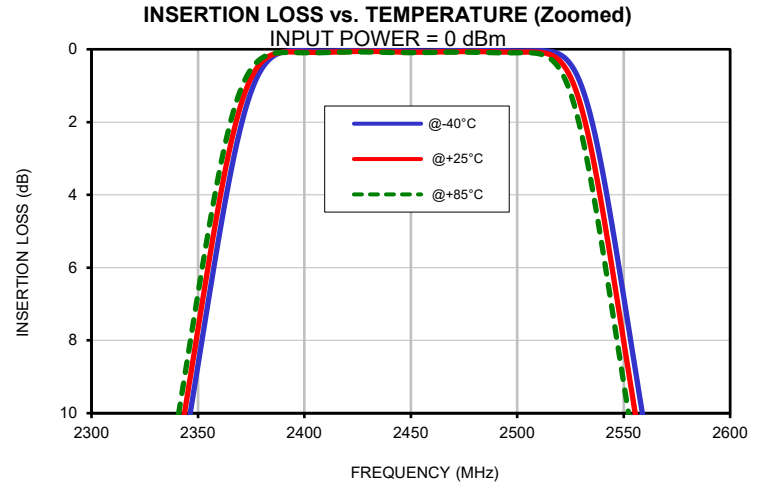
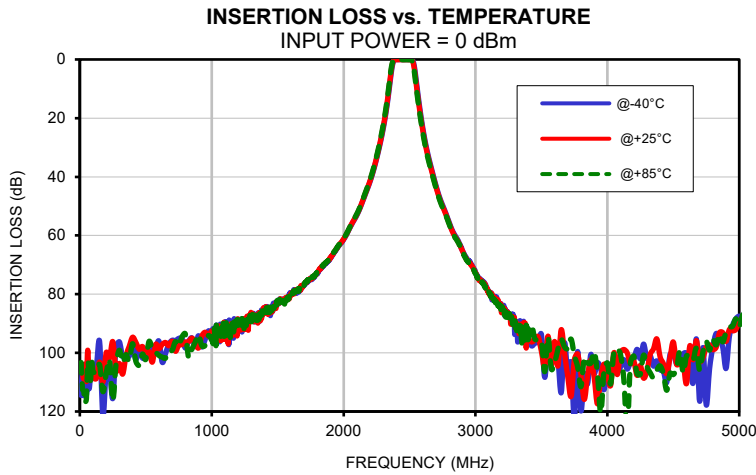

## Outline Dimensions

BBD3778

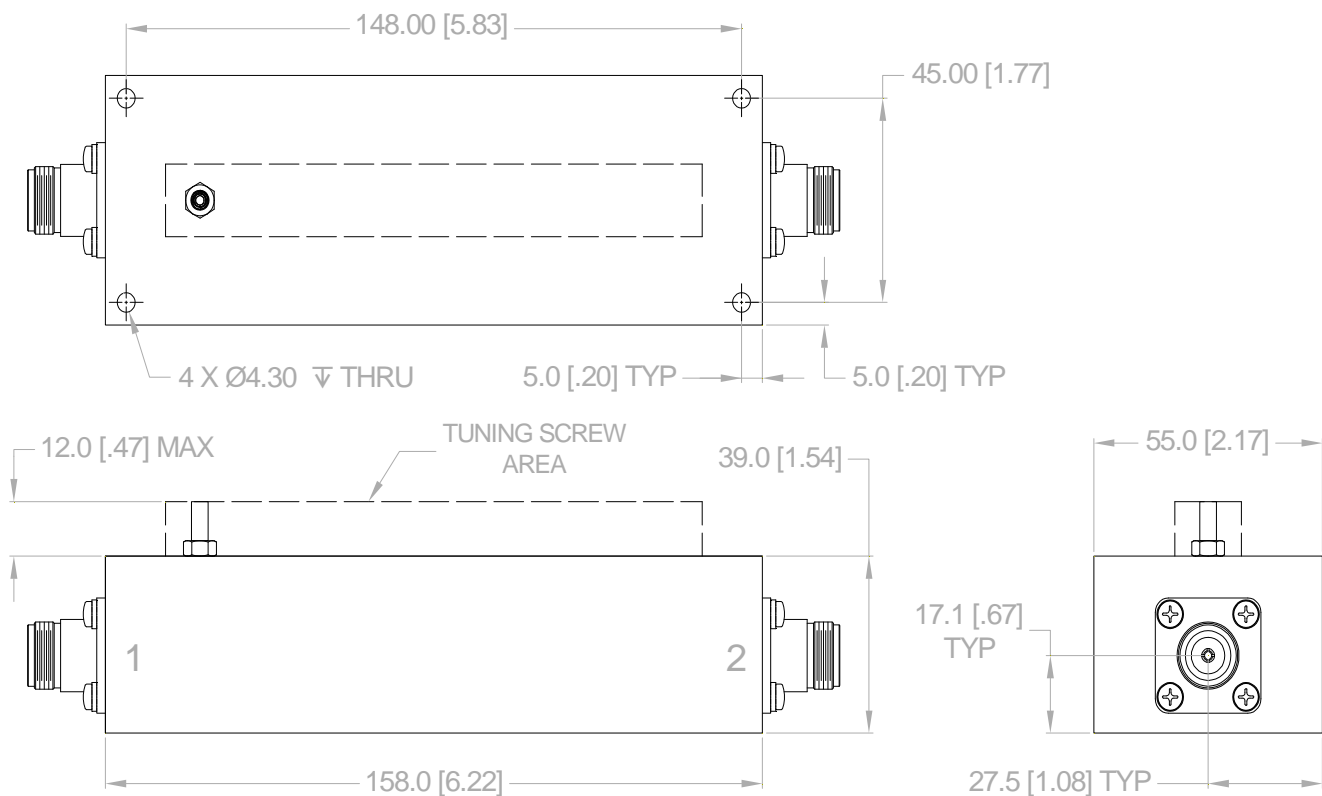

Dimensions are in mm (inches). Tolerances: 1 Pl.  $\pm 1.5$  (0.06); 2 Pl.  $\pm 0.38$  (0.015)

### Notes:

1. Case material: Aluminum.
2. Case Finish: silver plating
3. Unit Weight: 565 grams.
4. Refer to the individual model data sheet for the type of connectors available.

**Mini-Circuits®**  
ISO 9001 ISO 14001 CERTIFIED

ALL NEW  
minicircuits.com

P.O. Box 350166, Brooklyn, New York 11235-0003 (718) 934-4500 Fax (718) 332-4661 For detailed performance specs & shopping online see Mini-Circuits web site



The Design Engineers Search Engine Provides ACTUAL Data Instantly From MINI-CIRCUITS At: [www.minicircuits.com](http://www.minicircuits.com)

RF/IF MICROWAVE COMPONENTS



## Environmental Specifications ENV77T1

All Mini-Circuits products are manufactured under exacting quality assurance and control standards, and are capable of meeting published specifications after being subjected to any or all of the following physical and environmental test.

Specification	Test/Inspection Condition	Reference/Spec
Operating Temperature	-30° to 70°C Ambient Environment	Individual Model Data Sheet
Storage Temperature	-30° to 70° C Ambient Environment	Individual Model Data Sheet
Thermal Shock	-55° to 100°C, 100 cycles	MIL-STD-202, Method 107, Condition A-3, except +100°C