



MEDIUM POWER, HIGH GAIN

Wideband Amplifier

ZVE-453HP+ ZVE-453HPX+

50Ω 18 to 45 GHz

THE BIG DEAL

- High gain 39 dB typ. over the entire operating band
- Excellent gain flatness, ±2.5 dB typ.
- Saturated output power = +31 dBm typ.
- Adjustable DC voltage, +10 to +15 V



Generic photo used for illustration purposes only

APPLICATIONS

- Wideband Test and Instrumentation
- 5G mmW
- SATCOM
- Wireless Infrastructure

Model No.	ZVE-453HP+	ZVE-453HPX+
Option	With heatsink & fan	Without heatsink & fan
Case Style	VN3071-4	
Connectors	2.4mm Female	

+RoHS Compliant

The +Suffix identifies RoHS Compliance. See our web site for RoHS Compliance methodologies and qualifications

PRODUCT OVERVIEW

Mini-Circuits' ZVE-453HP+ is a coaxial, 1 Watt wideband high gain amplifier, operating from 18 to 45 GHz. This model operates over a single positive supply range of +10 to +15 V, allowing users to choose their desired operating voltage. Internal DC-DC conversion circuitry maintains constant efficiency over the full input voltage range. The amplifier incorporates several DC-protection features, such as over-voltage, reverse voltage and in-rush current, that protect the amplifier from damage if mishandled during operation. The wideband operation combined with high output power makes this amplifier an ideal choice for testing and instrumentation applications.

KEY FEATURES

Feature	Advantages
Wide-band amplifier, 18 to 45 GHz	A single amplifier serves the need for applications including 5G bands (24 to 39 GHz), SATCOM, Test & Instrumentation, etc.
Integrated fan assembly	Model ZVE-453HP+ utilizes two integrated fans, keeping the amplifier cool to the touch during normal operation at room temperature
High gain Low VSWR Medium RF power	The amplifier provides 39 dB (typ.) of gain over the entire operating band, and is capable of delivering over 1 Watt of RF power
Adjustable DC Supply Voltage	The device is capable of operating from +10 to +15 V with consistent DC power consumption
DC Protection – Over-voltage Reverse voltage In-rush Current	The internal DC circuitry allows the amplifier to be protected from external mishandling, that could lead to catastrophic failures in the field

REV. A
ECO-012828
ZVE-453HP+
MCL NY
220414





MEDIUM POWER, HIGH GAIN

Wideband Amplifier

ZVE-453HP+ ZVE-453HPX+

ELECTRICAL SPECIFICATIONS AT 25 °C BASEPLATE

Parameter	Condition (MHz)	ZVE-453HP+ ³ ZVE-453HPX+ ⁴			Units
		Min.	Typ.	Max.	
Frequency Range		18000		45000	MHz
Gain	18000-30000	33.0	37		dB
	30000-45000	35.0	40		
Output Power at 1dB compression	18000 – 26000	25.0	29.0		dBm
	26000 – 40000	29.0	30.5		
	40000 – 45000	25.5	28.5		
Saturated Output Power	18000 – 26000	28.0	30.5		dBm
	26000 – 40000	30.5	32.0		
	40000 – 45000	27.5	30.0		
Output IP3	18000 – 45000		41		dBm
Input VSWR	18000 – 45000		1.5	2.0	:1
Output VSWR ¹	18000 – 45000		1.5	2.0	:1
Operating DC Voltage		+10	—	+15	V
Device Operating Current at +15 V (ZVE-453HPX+ / ZVE-453HP+)			900 ⁴ / 1100 ³	1600 ⁴ / 1800 ³	mA
Device Operating Power at +15 V			19 ²		W

1. Open and short-circuit loads are not recommended at the amplifier output. Ensure proper 50 Ohm load before turning the amplifier "ON".
2. Device operating power is based on current when amplifier is in saturation.
3. For units with heatsink, limit ambient temperature to 50 °C.
4. For units without heatsink, limit the maximum baseplate temperature to 60 °C.

MAXIMUM RATINGS⁶

Parameter	Ratings
Operating Temperature	ZVE-453HP+ -40 °C to +50 °C Ambient ZVE-453HPX+ -40 °C to +60 °C Baseplate
Storage Temperature	-40 °C to +85 °C
Total Power Dissipation	20 W
RF Input Power ⁵ (CW)	+2 dBm
DC Operating Voltage	+16 V

5. Specified under matched load to 50 ohms.
6. Continuous operation is not recommended at these extremes. Permanent damage may occur if any of these limits are exceeded.



MEDIUM POWER, HIGH GAIN

Wideband Amplifier

ZVE-453HP+ ZVE-453HPX+

OUTLINE DRAWING FOR MODELS WITH HEATSINK & FAN (ZVE-453HP+)

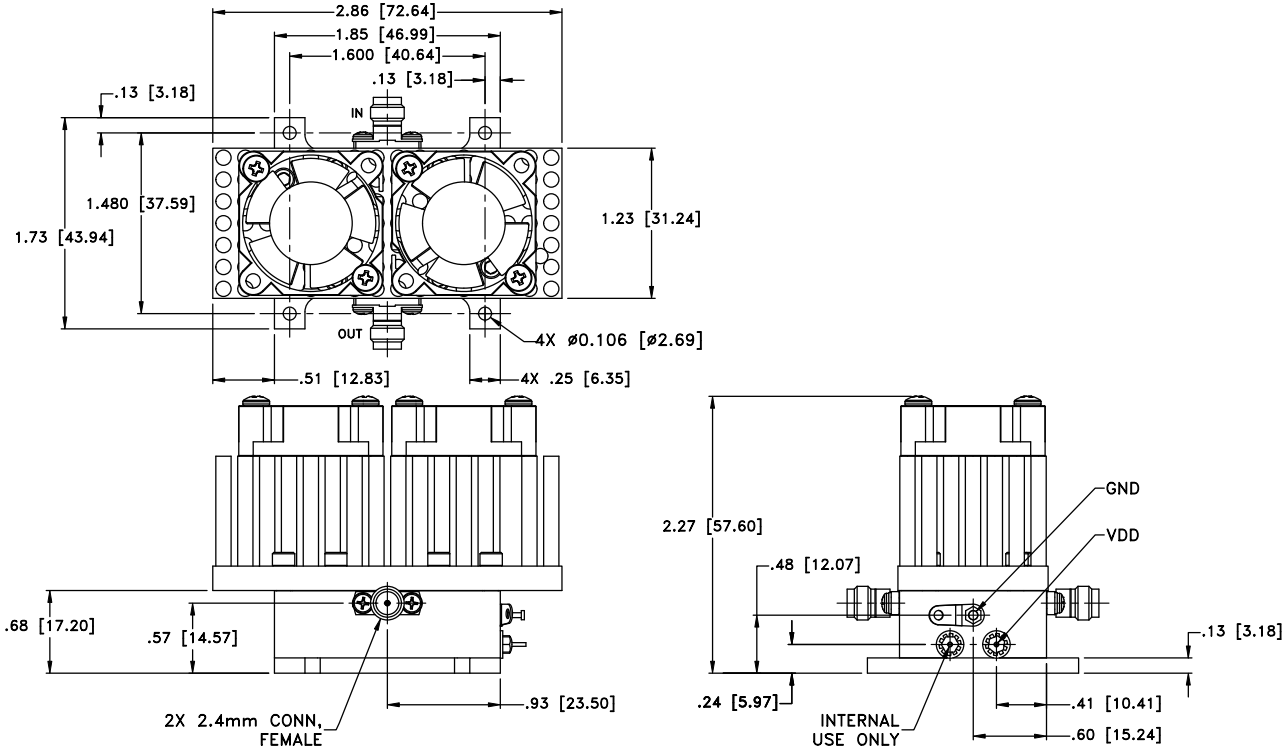

MOUNTING INFORMATION FOR MODELS WITHOUT HEATSINK & FAN (ZVE-453HPX+)

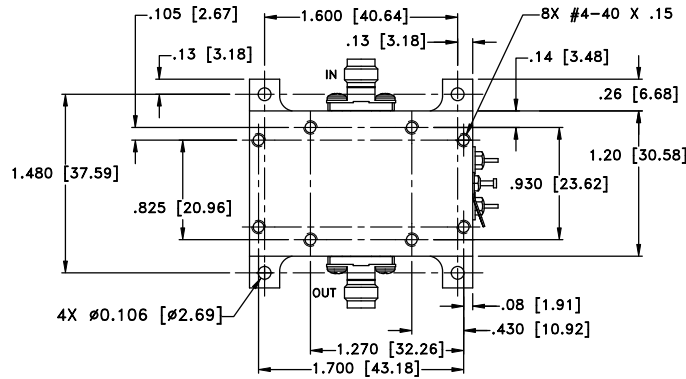

WT. GRAMS 160 grams; WITHOUT HEATSINK GRAMS 60 grams
Dimensions are in inches [mm]. Tolerances: 2 Pl. $\pm .03$; 3 Pl. $\pm .015$





MEDIUM POWER, HIGH GAIN

Wideband Amplifier

ZVE-453HP+ ZVE-453HPX+

TYPICAL PERFORMANCE DATA/CURVES

Frequency (MHz)	Gain (dB)	Directivity (dB)	VSWR (:1)		Pout @ 1 dB Compression (dBm)	Pout @ Saturation (dBm)	Output IP3 (dBm)
			IN	OUT			
18000	38.95	56.99	1.56	1.30	26.89	29.23	35.57
21000	38.74	53.83	1.27	1.17	30.31	31.04	40.71
24000	36.85	53.88	1.10	1.31	30.28	31.30	40.20
27000	36.80	46.04	1.23	1.21	31.10	32.47	45.85
30000	39.08	46.57	1.04	1.26	30.81	32.64	41.07
33000	39.66	51.30	1.05	1.22	30.64	32.37	41.05
36000	41.58	42.67	1.43	1.43	30.69	31.84	40.16
39000	39.83	50.34	1.33	1.67	30.35	31.42	38.76
42000	40.67	39.41	1.58	1.61	29.23	30.87	39.23
45000	40.85	38.74	1.85	1.40	27.18	29.16	37.82

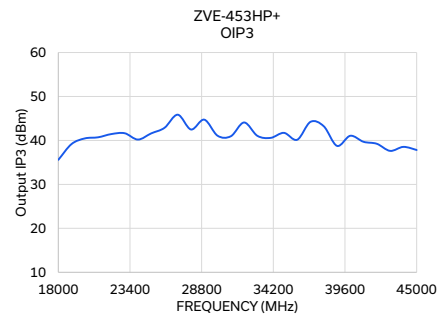
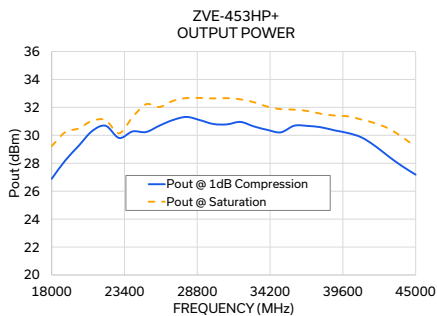
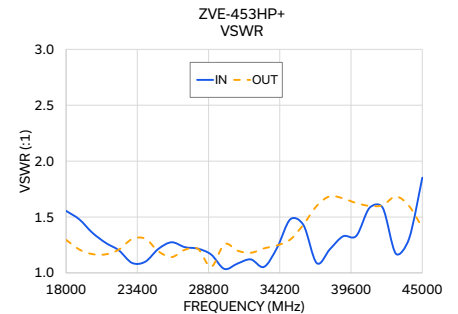
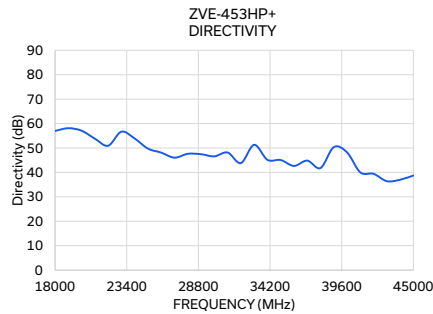
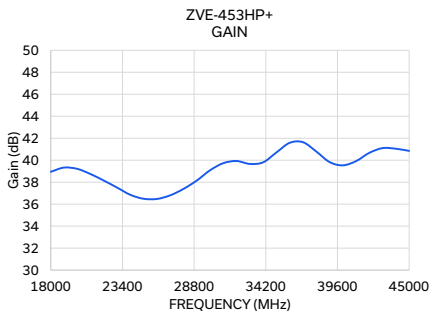

- NOTES**
- A. Performance and quality attributes and conditions not expressly stated in this specification document are intended to be excluded and do not form a part of this specification document.
 - B. Electrical specifications and performance data contained in this specification document are based on Mini-Circuit's applicable established test performance criteria and measurement instructions.
 - C. The parts covered by this specification document are subject to Mini-Circuits standard limited warranty and terms and conditions (collectively, "Standard Terms"); Purchasers of this part are entitled to the rights and benefits contained therein. For a full statement of the standard. Terms and the exclusive rights and remedies thereunder, please visit Mini-Circuits' website at www.minicircuits.com/MCLStore/terms.jsp



Wideband Amplifier

ZVE-453HP+

Typical Performance Data

FREQ. (MHz)	GAIN (dB) 15V	DIRECTIVITY (dB) 15V	VSWR (:1)		Pout @ 1 dB COMPRESSION (dBm) 15V	Pout @ SATURATION (dBm) 15V	OUTUPUT IP3 (dBm) 15V
			IN 15V	OUT 15V			
18000	38.95	56.99	1.56	1.30	26.89	29.23	35.57
19000	39.33	58.10	1.48	1.21	28.19	30.23	39.18
20000	39.21	57.09	1.36	1.17	29.25	30.49	40.46
21000	38.74	53.83	1.27	1.17	30.31	31.04	40.71
22000	38.14	50.93	1.20	1.21	30.68	31.09	41.45
23000	37.50	56.69	1.09	1.30	29.81	30.14	41.64
24000	36.85	53.88	1.10	1.31	30.28	31.30	40.20
25000	36.49	49.75	1.21	1.19	30.24	32.22	41.60
26000	36.48	48.10	1.27	1.14	30.70	32.03	42.86
27000	36.80	46.04	1.23	1.21	31.10	32.47	45.85
28000	37.39	47.62	1.22	1.22	31.32	32.67	42.48
29000	38.15	47.45	1.16	1.05	31.09	32.68	44.73
30000	39.08	46.57	1.04	1.26	30.81	32.64	41.07
31000	39.73	48.15	1.08	1.20	30.78	32.66	40.95
32000	39.93	43.81	1.12	1.18	30.96	32.57	44.08
33000	39.66	51.30	1.05	1.22	30.64	32.37	41.05
34000	39.81	45.16	1.23	1.25	30.39	32.06	40.58
35000	40.71	45.08	1.48	1.30	30.21	31.87	41.72
36000	41.58	42.67	1.43	1.43	30.69	31.84	40.16
37000	41.64	44.83	1.09	1.60	30.67	31.74	44.22
38000	40.80	41.80	1.21	1.69	30.57	31.54	43.23
39000	39.83	50.34	1.33	1.67	30.35	31.42	38.76
40000	39.53	48.21	1.33	1.62	30.16	31.35	41.06
41000	39.92	40.01	1.58	1.60	29.84	31.12	39.68
42000	40.67	39.41	1.58	1.61	29.23	30.87	39.23
43000	41.10	36.41	1.17	1.68	28.48	30.48	37.62
44000	41.04	37.01	1.31	1.60	27.79	29.88	38.53
45000	40.85	38.74	1.85	1.40	27.18	29.16	37.82

Typical Performance Curves

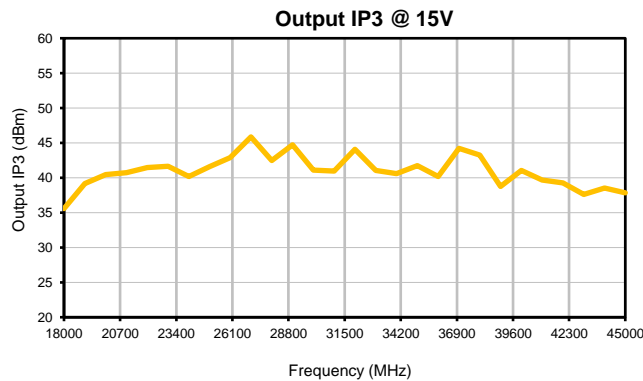
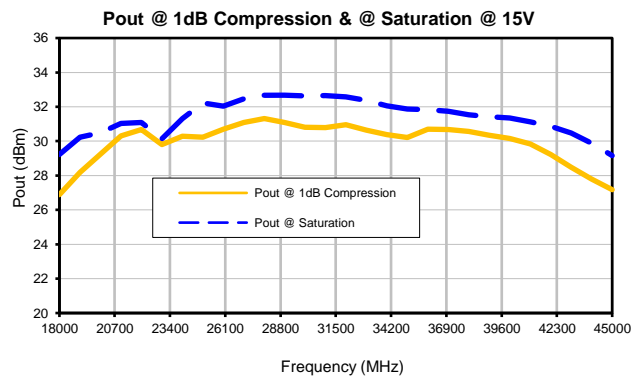
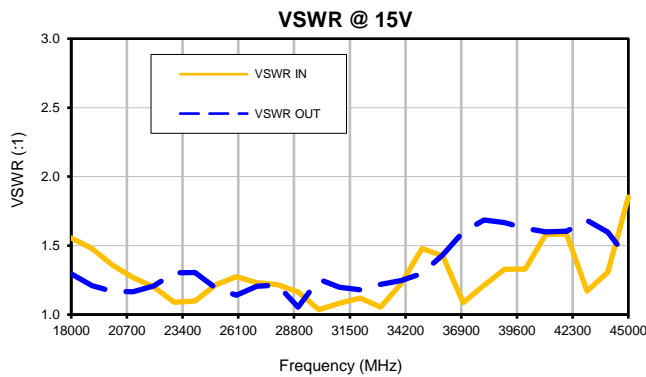
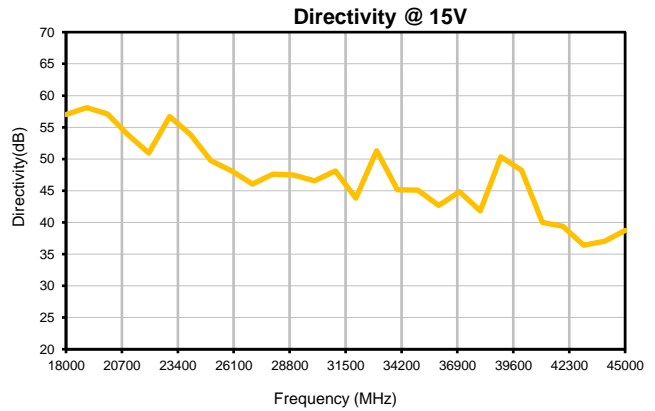
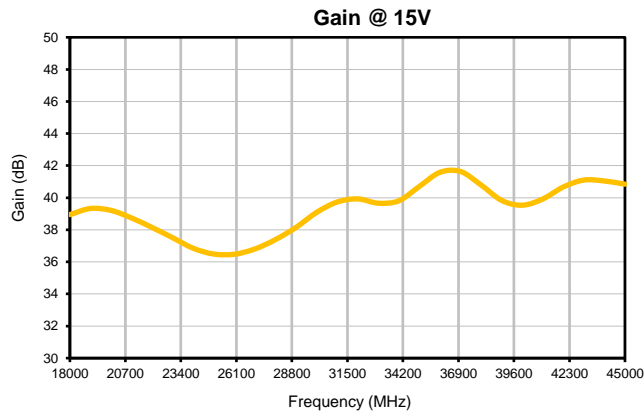

Case Style

VN

Qwvnpkg" Fk o gpukqpu

XP5293/6

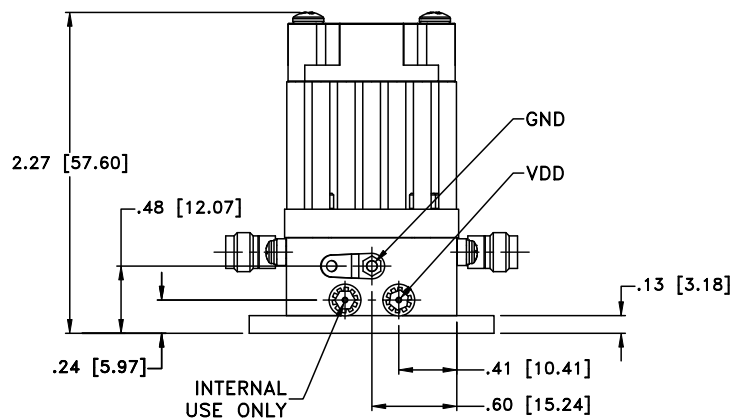
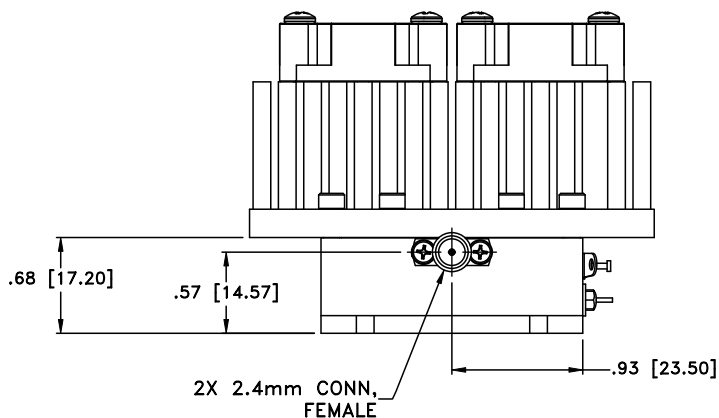
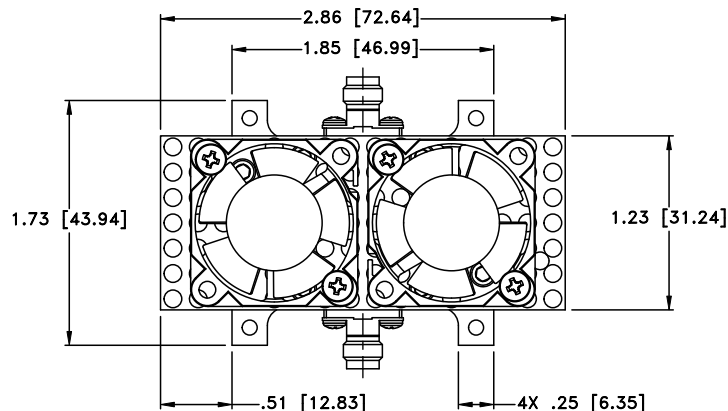

OQWPVKP I'KPHQTOCVKQP'QH'OQFGN'YIVJQWV'JGCVUKPM

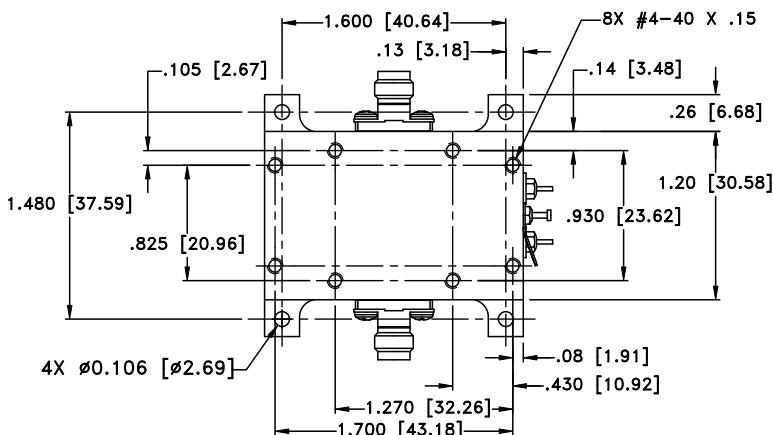

Y V0 Y V0I TCO U'382'i tco u=""Y KJ QWV'J GCVUKPMI TCO U'82'i tco u"

Flo gpukqpu'ctg'lp'pej gu"o o #0Vqrgtcegu<4'Rr0025="5'Rr00237"

Pqvgu<

30 Ecug'o cvgtkn<Cno kpwo 0

40 Ecug'hpkuj <I qif 'r rvpki =

50 J gcvukpmihpkuj <""Drcen'cpqf k g0

60 Tghgt'vq'v'j g'lpf kxf wcnb qf gnf'cvc'uj gg'vht'v'j g'v'r g'qh'epppgevqtu'cxckrdrg0

70 Uj cr g'qh'epppgevqt'hrpi g'o c{ 'xct{0



P.O. Box 350166, Brooklyn, New York 11235-0003 (718) 934-4500 Fax (718) 332-4661 For detailed performance specs & shopping online see Mini-Circuits web site

The Design Engineers Search Engine Provides ACTUAL Data Instantly From MINI-CIRCUITS At: www.minicircuits.com



RF/IF MICROWAVE COMPONENTS

All Mini-Circuits products are manufactured under exacting quality assurance and control standards, and are capable of meeting published specifications after being subjected to any or all of the following physical and environmental test.

Specification	Test/Inspection Condition	Reference/Spec
Operating Temperature	-40° to +60° C Baseplate Temp	Individual Model Data Sheet
Storage Temperature	-40° to +85° C Ambient Environment	Individual Model Data Sheet
Burn-in	(DC on) 72 hours at 25°C	----
Thermal Shock	-40° C to +85°C, 100 cycles	Transition time = 5 mins, Dwell time = 30 mins
Vibration	Random Vibration (non-operating)	MIL-STD-883K, Method 2025, Cond. 1A