

Coaxial High Pass Filter

ZX75HP-305-S+

50Ω 420 to 3200 MHz

The Big Deal

- Low insertion loss
- High rejection
- Connectorized package



Generic photo used for illustration purposes only

CASE STYLE: KE1467

Product Overview

ZX75HP-305-S+ is a High pass filter in a rugged connectorized package covering 420 to 3200 MHz. This filter will find its application in TV Broadcast, point-to-point military radio and cordless telephones. It has repeatable performance across production lots and consistent performance across temperature.

Key Features

Feature	Advantages
Low insertion loss	Can be used in high performance applications.
Good rejection	This enables the filter to attenuate spurious signals and reject harmonics for broad band frequency.
Connectorized package	The connectorized package is easy to interface with other devices and well suited for test setups.

Notes

- A. Performance and quality attributes and conditions not expressly stated in this specification document are intended to be excluded and do not form a part of this specification document.
B. Electrical specifications and performance data contained in this specification document are based on Mini-Circuit's applicable established test performance criteria and measurement instructions.
C. The parts covered by this specification document are subject to Mini-Circuits standard limited warranty and terms and conditions (collectively, "Standard Terms"); Purchasers of this part are entitled to the rights and benefits contained therein. For a full statement of the Standard Terms and the exclusive rights and remedies thereunder, please visit Mini-Circuits' website at www.minicircuits.com/MCLStore/terms.jsp



Coaxial High Pass Filter

ZX75HP-305-S+

50Ω 420 to 3200 MHz



Generic photo used for illustration purposes only

CASE STYLE: KE1467

Connectors	Model
SMA-MF	ZX75HP-305-S+

Features

- Wide band, 420 MHz to 3200 MHz
- High rejection
- Connectorized package

Applications

- TV Broadcast
- Point-to-point military radio
- Cordless telephones

Electrical Specifications at 25°C

Parameter	F#	Frequency (MHz)	Min.	Typ.	Max.	Unit	
Stop Band	Rejection Loss	DC-F1	DC-215	20	30	-	dB
	VSWR	DC-F1	DC-215	-	65	-	:1
Pass Band	Insertion Loss	F2-F3	420-3200	-	0.6	1.5	dB
	VSWR	F2-F3	420-3200	-	1.34	-	:1

Maximum Ratings

Operating Temperature	-40°C to 85°C
Storage Temperature	-55°C to 100°C
RF Power Input	0.5 W.

Permanent damage may occur if any of these limits are exceeded.

Functional Schematic

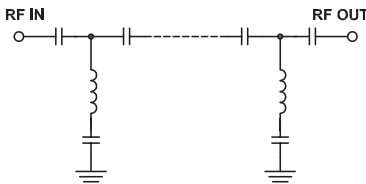

Typical Performance Data at 25°C

Frequency (MHz)	Insertion Loss (dB)	VSWR (:1)
1	107.92	1737.18
75	85.53	868.59
120	66.04	347.44
160	50.22	173.72
185	41.04	108.58
215	30.59	66.82
260	15.60	23.81
285	7.86	8.64
305	3.33	3.27
320	1.65	1.83
360	0.69	1.15
400	0.53	1.08
420	0.48	1.05
600	0.39	1.32
1200	0.29	1.10
1620	0.34	1.22
2110	0.39	1.20
2550	0.42	1.12
2930	0.45	1.12
3200	0.51	1.21

Typical Frequency Response

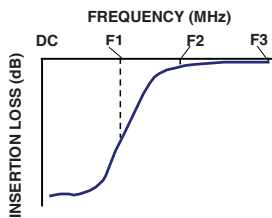

+RoHS Compliant
The +Suffix identifies RoHS Compliance. See our web site for RoHS Compliance methodologies and qualifications

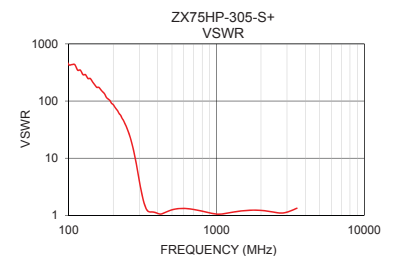
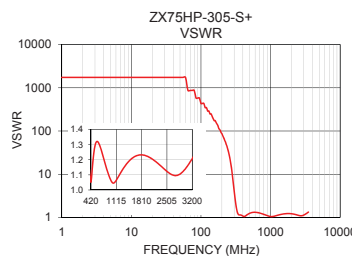
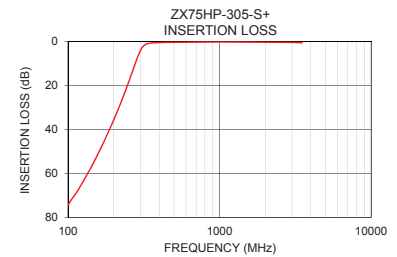
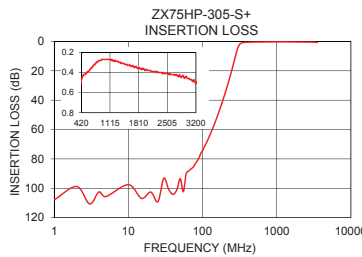

Notes

- Performance and quality attributes and conditions not expressly stated in this specification document are intended to be excluded and do not form a part of this specification document.
- Electrical specifications and performance data contained in this specification document are based on Mini-Circuits' applicable established test performance criteria and measurement instructions.
- The parts covered by this specification document are subject to Mini-Circuits standard limited warranty and terms and conditions (collectively, "Standard Terms"); Purchasers of this part are entitled to the rights and benefits contained therein. For a full statement of the Standard Terms and the exclusive rights and remedies thereunder, please visit Mini-Circuits' website at www.minicircuits.com/MCLStore/terms.jsp



www.minicircuits.com P.O. Box 350166, Brooklyn, NY 11235-0003 (718) 934-4500 sales@minicircuits.com

REV.C
ECO-004400
ZX75HP-305-S+
EDU1698
URJ
201010
Page 2 of 3

Coaxial Connections

INPUT	SMA-Male
OUTPUT	SMA-Female

Outline Drawing

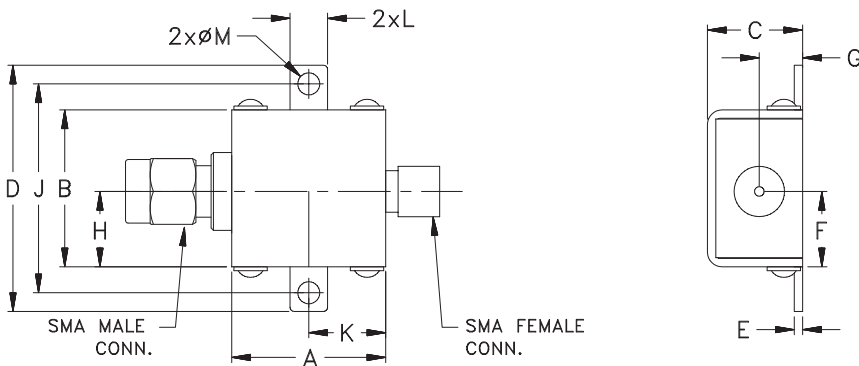

Outline Dimensions ($\frac{\text{inch}}{\text{mm}}$)

A	B	C	D	E	F	G
.74	.75	.46	1.18	.04	.362	.21
18.80	19.05	11.68	29.97	1.02	9.19	5.33
H	J	K	L	M		Wt.
.362	1.00	.37	.18	.11		grams
9.19	25.40	9.40	4.57	2.79		24.4

Note: Please refer to case style drawing for details

Notes

- A. Performance and quality attributes and conditions not expressly stated in this specification document are intended to be excluded and do not form a part of this specification document.
 B. Electrical specifications and performance data contained in this specification document are based on Mini-Circuit's applicable established test performance criteria and measurement instructions.
 C. The parts covered by this specification document are subject to Mini-Circuits standard limited warranty and terms and conditions (collectively, "Standard Terms"); Purchasers of this part are entitled to the rights and benefits contained therein. For a full statement of the Standard Terms and the exclusive rights and remedies thereunder, please visit Mini-Circuits' website at www.minicircuits.com/MCLStore/terms.jsp



Typical Performance Data

FREQ. (MHz)	INSERTION LOSS			INPUT RETURN LOSS			OUTPUT RETURN LOSS		
	(dB)			(dB)			(dB)		
	@-40°C	@+25°C	@+85°C	@-40°C	@+25°C	@+85°C	@-40°C	@+25°C	@+85°C
1	97.87	107.92	114.57	0.00	0.00	0.00	0.00	0.00	0.00
5	107.51	105.64	114.67	0.00	0.00	0.00	0.00	0.00	0.00
25	119.30	109.13	102.36	0.00	0.00	0.01	0.00	0.00	0.01
50	94.42	93.49	94.46	0.00	0.01	0.01	0.00	0.01	0.01
75	86.53	85.53	87.36	0.01	0.02	0.02	0.01	0.02	0.02
100	74.63	74.41	74.66	0.02	0.03	0.04	0.02	0.04	0.04
125	64.29	64.05	63.86	0.03	0.05	0.06	0.04	0.06	0.07
150	54.13	54.06	53.93	0.05	0.08	0.09	0.06	0.09	0.10
155	52.27	52.19	52.04	0.06	0.09	0.10	0.07	0.10	0.11
160	50.35	50.22	50.18	0.07	0.09	0.11	0.07	0.10	0.12
165	48.49	48.37	48.23	0.07	0.10	0.12	0.08	0.11	0.13
170	46.57	46.50	46.39	0.08	0.11	0.13	0.09	0.12	0.14
175	44.73	44.68	44.56	0.09	0.12	0.14	0.10	0.13	0.15
180	42.88	42.85	42.75	0.10	0.13	0.15	0.11	0.15	0.17
185	41.08	41.04	40.96	0.11	0.14	0.16	0.12	0.16	0.18
190	39.28	39.27	39.18	0.12	0.16	0.18	0.13	0.17	0.19
195	37.50	37.50	37.43	0.13	0.17	0.19	0.15	0.19	0.21
200	35.75	35.76	35.69	0.15	0.18	0.21	0.16	0.20	0.23
205	34.00	34.02	33.96	0.16	0.20	0.22	0.18	0.22	0.25
210	32.27	32.30	32.25	0.18	0.22	0.24	0.20	0.24	0.27
215	30.56	30.59	30.55	0.19	0.24	0.26	0.21	0.26	0.29
220	28.85	28.90	28.86	0.21	0.26	0.29	0.24	0.29	0.32
225	27.16	27.21	27.18	0.24	0.28	0.31	0.26	0.31	0.35
230	25.48	25.53	25.51	0.26	0.31	0.34	0.29	0.35	0.38
235	23.80	23.85	23.84	0.29	0.34	0.38	0.33	0.38	0.42
240	22.14	22.19	22.18	0.33	0.38	0.42	0.37	0.43	0.47
245	20.49	20.53	20.53	0.37	0.43	0.47	0.41	0.48	0.52
250	18.84	18.88	18.87	0.43	0.49	0.53	0.47	0.55	0.60
255	17.21	17.24	17.23	0.49	0.56	0.61	0.55	0.63	0.68
260	15.59	15.60	15.59	0.58	0.66	0.71	0.64	0.73	0.79
265	13.99	13.98	13.97	0.69	0.78	0.84	0.77	0.87	0.94
270	12.41	12.39	12.37	0.84	0.94	1.01	0.93	1.05	1.13
275	10.86	10.82	10.80	1.03	1.16	1.24	1.14	1.28	1.38
280	9.36	9.31	9.27	1.30	1.45	1.55	1.42	1.60	1.71
285	7.93	7.86	7.82	1.66	1.84	1.96	1.80	2.02	2.16
285	7.93	7.86	7.82	1.66	1.84	1.96	1.80	2.02	2.16
290	6.59	6.52	6.48	2.14	2.37	2.52	2.31	2.58	2.76
295	5.37	5.30	5.26	2.77	3.06	3.26	2.97	3.32	3.56
300	4.29	4.23	4.20	3.59	3.96	4.21	3.84	4.28	4.58
305	3.37	3.33	3.31	4.62	5.08	5.40	4.93	5.48	5.87
310	2.62	2.61	2.61	5.88	6.44	6.84	6.26	6.94	7.44
315	2.03	2.05	2.07	7.37	8.03	8.53	7.85	8.67	9.31
320	1.60	1.65	1.67	9.09	9.85	10.46	9.69	10.67	11.46
325	1.28	1.35	1.39	11.01	11.86	12.57	11.77	12.90	13.88
330	1.05	1.14	1.19	13.11	14.02	14.81	14.06	15.32	16.50
335	0.89	0.99	1.05	15.33	16.25	17.10	16.50	17.83	19.16
340	0.79	0.89	0.96	17.61	18.44	19.27	18.96	20.19	21.49
400	0.44	0.53	0.59	29.35	33.94	37.50	27.05	28.24	28.28
420	0.39	0.48	0.53	44.33	38.58	33.04	34.72	32.00	29.24
450	0.35	0.44	0.50	27.84	24.96	23.17	27.79	24.78	22.88
500	0.33	0.42	0.48	20.45	19.48	18.56	20.11	19.18	18.26
750	0.24	0.32	0.36	20.38	21.03	21.34	19.44	19.93	20.16
1000	0.18	0.27	0.32	32.39	42.36	38.32	30.01	32.19	29.91
1500	0.18	0.32	0.41	26.15	21.97	19.78	24.40	20.87	18.89
2000	0.21	0.37	0.47	23.52	20.80	19.12	22.46	20.13	18.60
2500	0.22	0.41	0.53	28.71	24.21	22.70	29.71	24.69	22.71
2900	0.25	0.44	0.57	23.38	25.40	26.26	23.30	25.54	25.88
3000	0.26	0.46	0.60	22.31	24.08	24.62	22.00	23.91	24.21
3100	0.26	0.48	0.62	21.59	22.51	22.57	21.08	22.18	22.16
3200	0.29	0.51	0.66	20.85	20.99	20.69	20.23	20.61	20.34

High Pass Filter

ZX75HP-305-S+

Typical Performance Data

FREQ. (MHz)	GROUP DELAY		
	(nsec)		
	@-40°C	@+25°C	@+85°C
420	2.26	2.25	2.24
425	2.19	2.18	2.17
430	2.13	2.12	2.11
435	2.07	2.06	2.05
440	2.02	2.00	1.99
445	1.96	1.95	1.94
450	1.91	1.90	1.89
455	1.86	1.85	1.84
460	1.82	1.80	1.79
465	1.77	1.76	1.75
470	1.73	1.71	1.70
475	1.69	1.67	1.66
480	1.65	1.64	1.63
485	1.61	1.60	1.59
490	1.58	1.56	1.55
495	1.54	1.53	1.52
500	1.51	1.50	1.49
505	1.48	1.47	1.46
510	1.45	1.44	1.43
515	1.42	1.41	1.40
520	1.39	1.38	1.37
525	1.37	1.35	1.34
530	1.34	1.33	1.32
535	1.32	1.30	1.29
540	1.29	1.28	1.27
545	1.27	1.25	1.25
550	1.24	1.23	1.22
555	1.22	1.21	1.20
560	1.19	1.18	1.17
570	1.16	1.15	1.15
580	1.13	1.12	1.12
590	1.11	1.09	1.09
600	1.07	1.06	1.06
610	1.04	1.03	1.03
620	1.01	1.00	1.00
640	0.96	0.95	0.95
650	0.94	0.93	0.92
660	0.91	0.90	0.90
670	0.89	0.88	0.88
680	0.87	0.86	0.86
690	0.85	0.84	0.84
700	0.83	0.83	0.82
750	0.75	0.75	0.74
800	0.69	0.68	0.68
850	0.64	0.63	0.63
900	0.59	0.59	0.58
1000	0.53	0.52	0.51
1100	0.48	0.47	0.46
1200	0.44	0.43	0.43
1300	0.41	0.40	0.40
1400	0.39	0.38	0.38
1500	0.37	0.36	0.36
1600	0.36	0.35	0.34
1700	0.34	0.33	0.33
2000	0.32	0.31	0.31
2500	0.30	0.29	0.28
2700	0.29	0.28	0.28
3000	0.29	0.28	0.28
3100	0.28	0.28	0.27
3200	0.29	0.28	0.27

High Pass Filter

ZX75HP-305-S+

Typical Performance Curves

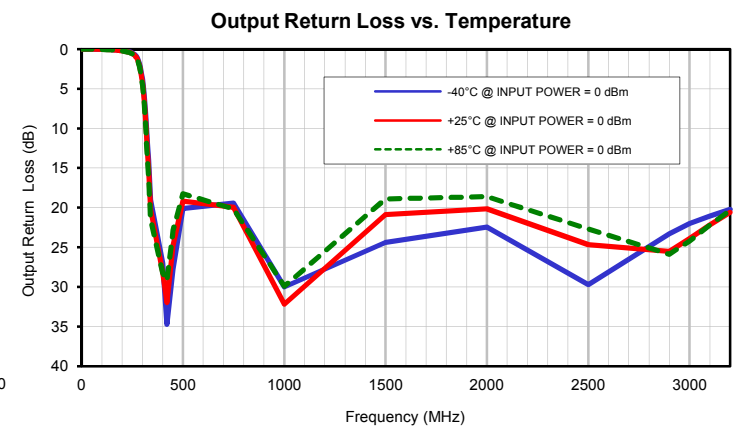
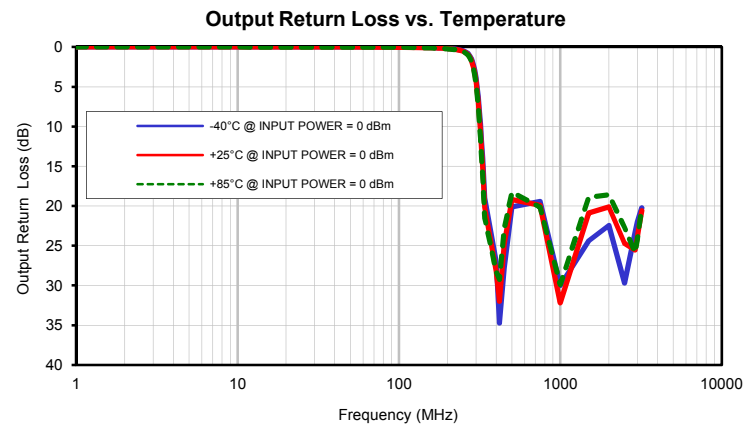
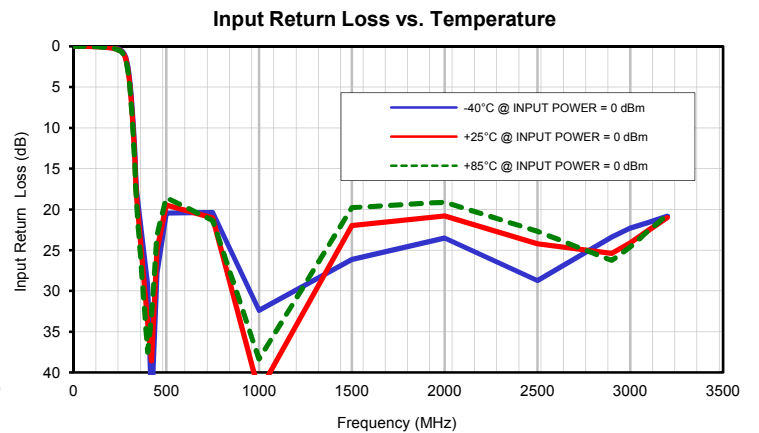
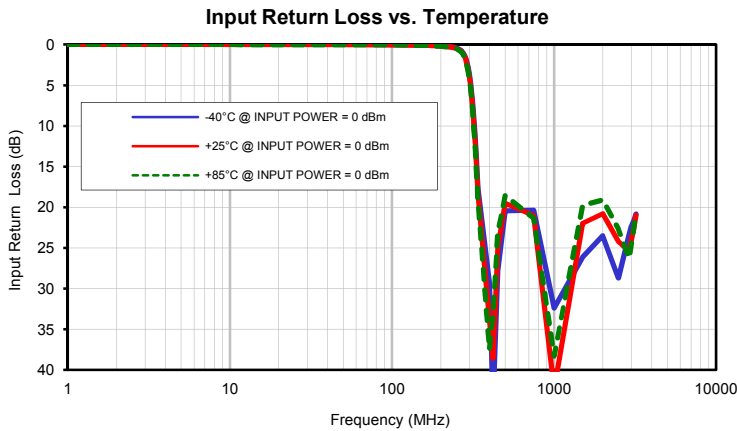
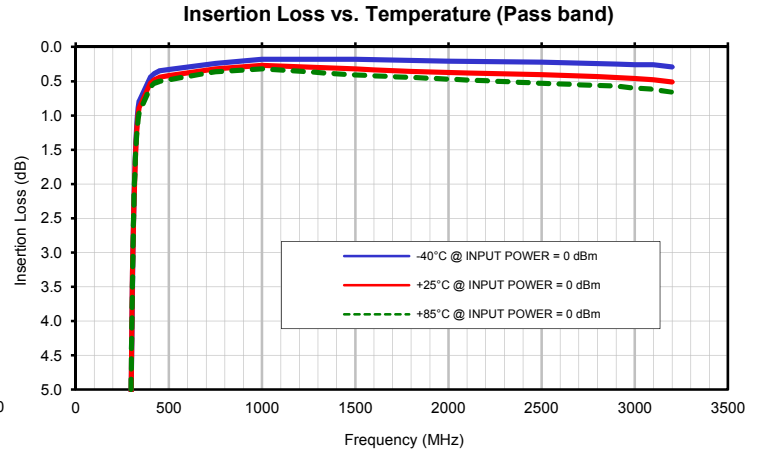
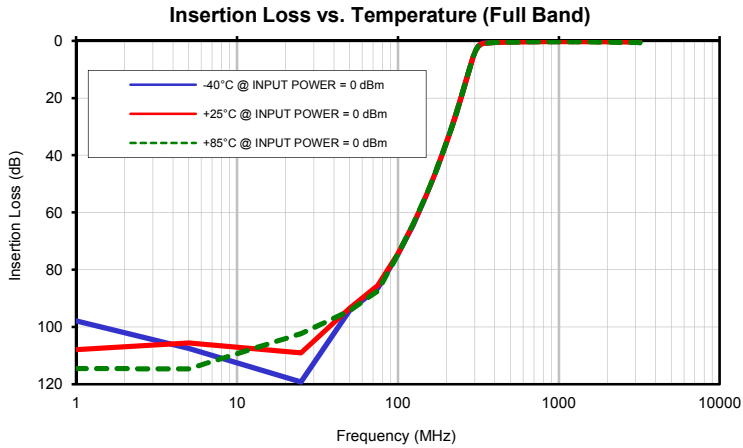

P.O. Box 350166, Brooklyn, New York 11235-0003 (718) 934-4500 • Fax (718) 332-4661 For detailed performance specs & shopping online see Mini-Circuits web site
 The Design Engineers Search Engine Provides ACTUAL Data Instantly From MINI-CIRCUITS At: www.minicircuits.com



IF/RF MICROWAVE COMPONENTS

REV. A
 ZX75HP-305-S+
 190103
 Page 1 of 2

High Pass Filter

ZX75HP-305-S+

Typical Performance Curves

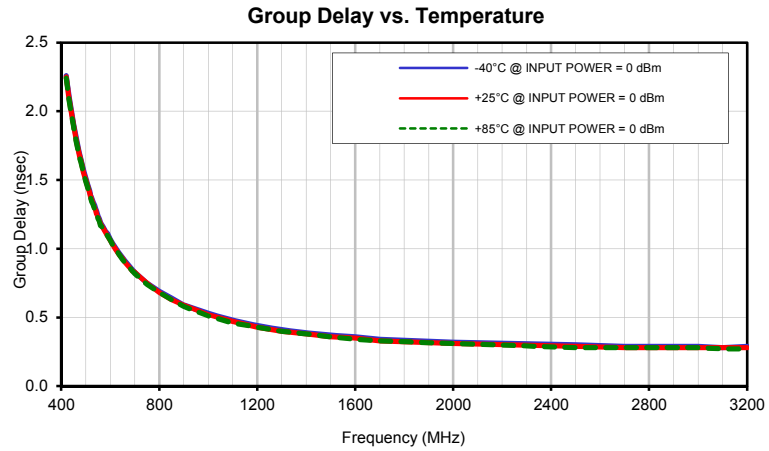

Outline Dimensions



CASE #.	A	B	C	D	E	F	G	H	J	K	L	M
KE1467	.74 (18.80)	.75 (19.05)	.46 (11.68)	1.18 (29.97)	.04 (1.02)	.362 (9.19)	.21 (5.33)	.362 (9.19)	1.00 (25.40)	.37 (9.40)	.18 (4.57)	.11 (2.79)

CASE #.	WT. GRAM
KE1467	24.4

Dimensions are in inches (mm). Tolerances: 2Pl. $\pm .03$; 3Pl. $\pm .015$

Tolerance on hole size and interaxes dimensions to be $\pm .005$.

Note:

1. Case material: Brass
2. Case finish: Gold
3. Cover: Nickel plated.



All Mini-Circuits products are manufactured under exacting quality assurance and control standards, and are capable of meeting published specifications after being subjected to any or all of the following physical and environmental test.

Specification	Test/Inspection Condition	Reference/Spec
Operating Temperature	-40° to 85°C	Individual Model Data Sheet
Storage Temperature	-55° to 100° C Ambient Environment	Individual Model Data Sheet
Barometric Pressure	100,000 Feet	MIL-STD-202, Method 105, Condition D
Humidity	90% RH, 65°C Units may require bake-out after humidity to restore full performance.	MIL-STD-202, Method 103
Thermal Shock	-65° to 125°C, 5 cycles	MIL-STD-202, Method 107, Condition B
Vibration (High Frequency)	20g peak, 10-2000 Hz, 12 times in each of three perpendicular directions (total 36)	MIL-STD-202, Method 204, Condition D
Mechanical Shock	100g, 6ms sawtooth, 3 shocks each direction 3 axes (total 18)	MIL-STD-202, Method 213, Condition I