

# NON-CATALOG

# Digital Step Attenuator

50Ω DC-4000 MHz

15.5 dB, 0.5 dB Step, 5 Bit, Parallel Control Interface  
Single Supply Voltage

## Product Features

- Low Insertion Loss
- High IP3, +52 dBm Typ
- Excellent return loss, 20 dB Typ
- Excellent accuracy, 0.1 dB Typ
- Single Supply Voltage: +3V
- Control inputs buffered by Schmitt Triggers
- Rigid unibody case
- Protected by US patent 6,790,049



CASE STYLE: HK1172

## ZX76-15R5-PP-S+

## Typical Applications

- Lab
- Instrumentation
- Test equipment

Connectors	Order P/N
SMA	ZX76-15R5-PP-S+

### +RoHS Compliant

The +Suffix identifies RoHS Compliance. See our web site for RoHS Compliance methodologies and qualifications

## General Description

The ZX76-15R5-PP-S+ is a 50Ω RF digital step attenuator that offers an attenuation range up to 15.5 dB in 0.5 dB steps. The control is a 5-bit parallel interface. The model operates on a single +3 volt supply. See application note AN-70-004 for 5V supply voltage. The ZX76-15R5-PP-S+ is produced using a unique case package for ruggedness and operation in tough environments.

## Simplified Schematic

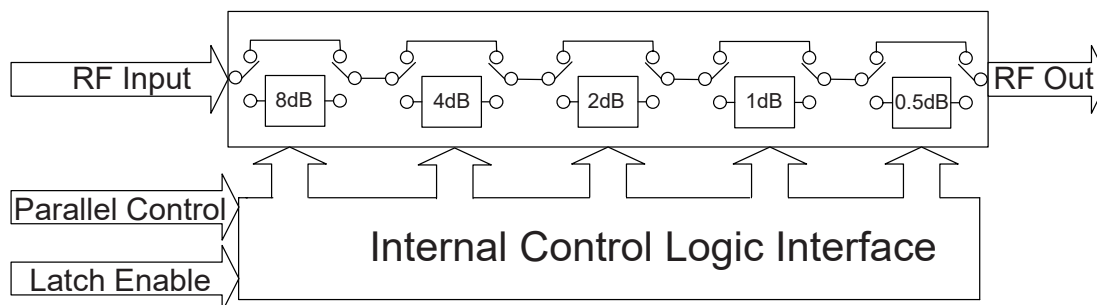

# NON-CATALOG

## Digital Step Attenuator

## ZX76-15R5-PP-S+

RF Electrical Specifications, DC-4000 MHz,  $T_{AMB}=25^{\circ}C$ ,  $V_{DD}=+3V$

Parameter	Freq. Range (GHz)	Min.	Typ.	Max.	Units
Accuracy @ 0.5 dB Attenuation Setting	DC-1	—	0.03	0.1	dB
	1-2.2	—	0.05	0.15	dB
	2.2-4.0	—	0.1	0.35	dB
Accuracy @ 1 dB Attenuation Setting	DC-1	—	0.02	0.1	dB
	1-2.2	—	0.05	0.15	dB
	2.2-4.0	—	0.1	0.35	dB
Accuracy @ 2 dB Attenuation Setting	DC-1	—	0.05	0.15	dB
	1-2.2	—	0.15	0.25	dB
	2.2-4.0	—	0.2	0.6	dB
Accuracy @ 4 dB Attenuation Setting	DC-1	—	0.07	0.2	dB
	1-2.2	—	0.15	0.25	dB
	2.2-4.0	—	0.18	0.6	dB
Accuracy @ 8 dB Attenuation Setting	DC-1	—	0.03	0.2	dB
	1-2.2	—	0.15	0.3	dB
	2.2-4.0	—	0.5	0.6	dB
Insertion Loss @ all attenuator set to 0dB	DC-1	—	1.5	2.0	dB
	1-2.2	—	1.8	2.5	dB
	2.2-4.0	—	3.0	4.5	dB
IP3 Input * (at Min. and Max. Attenuation)	DC-2.2	—	+52	—	dBm
	2.2-4.0	—	+42	—	dBm
Input Power @ 0.2dB Compression* (at Min. and Max. Attenuation)	DC-4.0	—	+24	—	dBm
VSWR	DC-1	—	1.2	1.5	—
	1-2.2	—	1.2	1.5	—
	2.2-4.0	—	1.8	2.1	—

\* IP3 and 1dB compression degrade below 1 MHz

### DC Electrical Specifications

Parameter	Min.	Typ.	Max.	Units
$V_{DD}$ , Supply Voltage	2.7	3	3.3	V
$I_{DD}$ , Supply Current	—	—	3	mA
Control Input Voltage Low	0	—	$0.3 \times V_{DD}$	V
Control Input Voltage High	$0.7 \times V_{DD}$	—	5V	V
Control Current	—	—	400	$\mu A$

### Switching Specifications

Parameter	Min.	Typ.	Max.	Units
Switching Speed, 50% Control to 0.5dB of Attenuation Value	—	1.0	—	$\mu Sec$
Switching Control Frequency	—	—	25	kHz

### Absolute Maximum Ratings

Parameter	Ratings
Operating Temperature	-40°C to 85°C
Storage Temperature	-40°C to 85°C
$V_{DD}$	-0.3V Min., 4V Max.
Voltage on Control Input	-0.3V Min., 6V Max.
ESD, HBM	500V
ESD, MM	100V
Input Power	+24dBm

Permanent damage may occur if any of these limits are exceeded



# NON-CATALOG

## Digital Step Attenuator

## ZX76-15R5-PP-S+

### Pin Description

Function	Pin Number	Description
LE	J1-1	Latch Enable Input
C1	J1-2	Control for attenuation bit, 1 dB
C0.5	J1-3	Control for attenuation bit, 0.5 dB
N/C	J1-4	Not Connected
-	J1-5	Not used
GND	J1-6	Ground connection
GND	J1-7	Ground connection
C4	J1-8	Control for attenuation bit, 4 dB
C8	J1-9	Control for attenuation bit, 8 dB
C2	J1-10	Control for attenuation bit, 2 dB
RF in	J2	RF in port (Note 1)
RF out	J3	RF out port (Note 1)
GND	P1	Ground connection
V <sub>DD</sub>	P2	Positive Supply Voltage

Note 1: Both RF ports must be held at 0VDC or DC blocked with an external series capacitor.

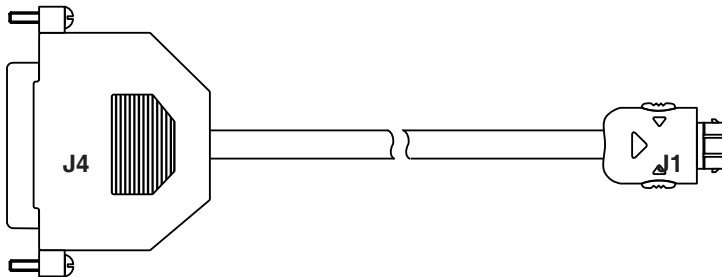

### Pin Configuration

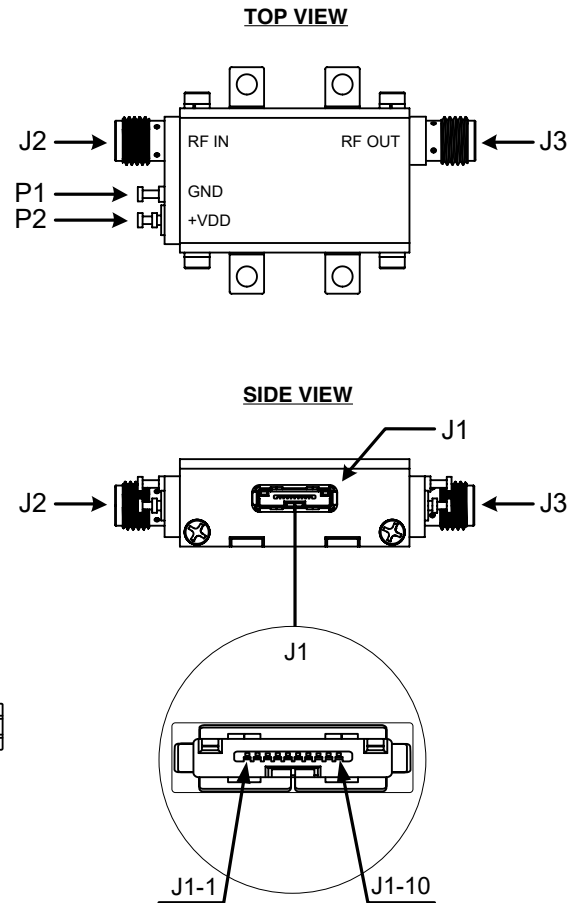

### Cable Pin Description

J1-Pin Number	J4-Pin Number	Function	Description	Wire Color
J1-1	J4-8	LE	Latch Enable Input	WHITE
J1-2	J4-3	C1	Control for attenuation bit, 1 dB	YELLOW
J1-3	J4-2	C0.5	Control for attenuation bit, 0.5 dB	GREEN
J1-5	J4-7	-	Not used	BLUE
J1-6	J4-20	GND	Ground connection	BLACK
J1-8	J4-5	C4	Control for attenuation bit, 4 dB	ORANGE
J1-9	J4-6	C8	Control for attenuation bit, 8 dB	BROWN
J1-10	J4-4	C2	Control for attenuation bit, 2 dB	RED

Note: Other pins not connected. Cable shield connected to case ground.

# NON-CATALOG

## Digital Step Attenuator

## ZX76-15R5-PP-S+

### Typical Performance Curves

INSERTION LOSS (Ref)

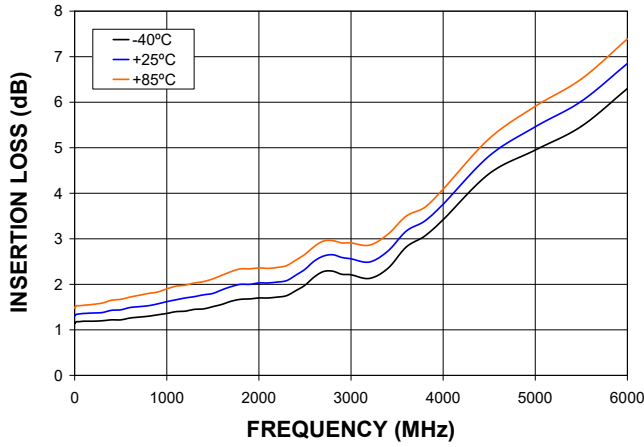

ATTENUATION (0.5 dB)

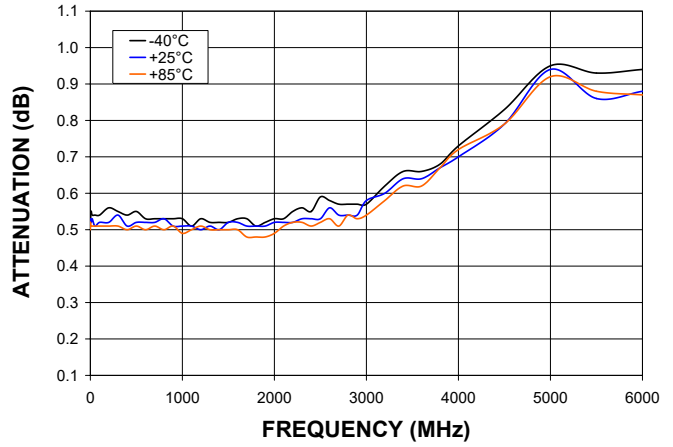

ATTENUATION (1 dB)

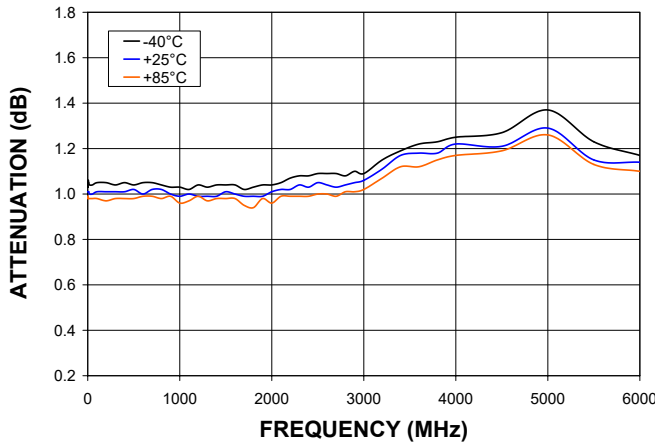

ATTENUATION (2 dB)

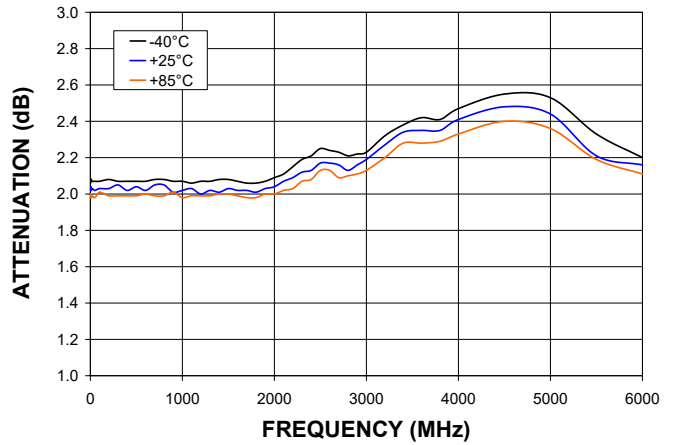

ATTENUATION (4 dB)

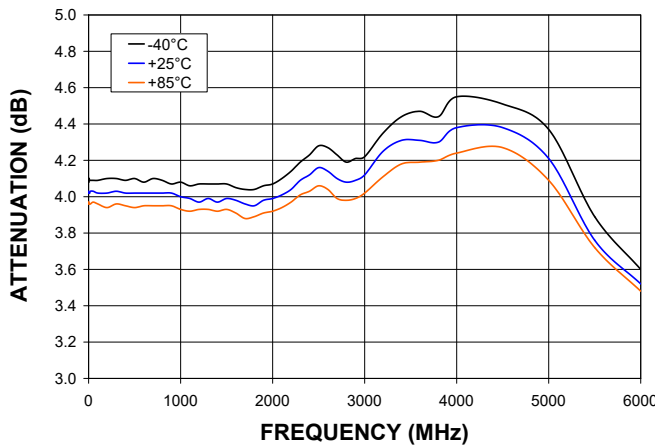

ATTENUATION (8 dB)

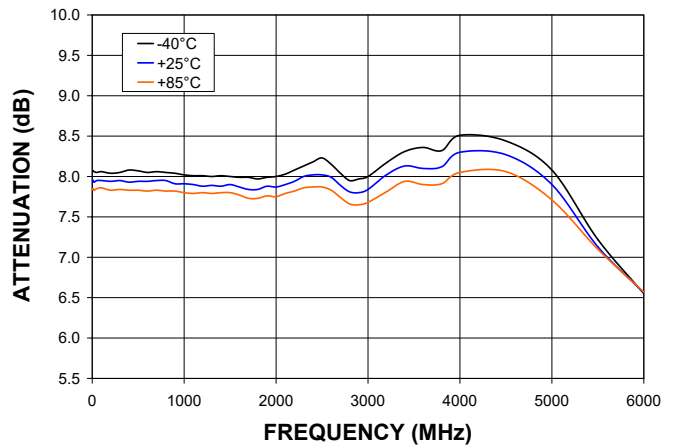

### Typical Performance Curves

#### ATTENUATION (15.5 dB)

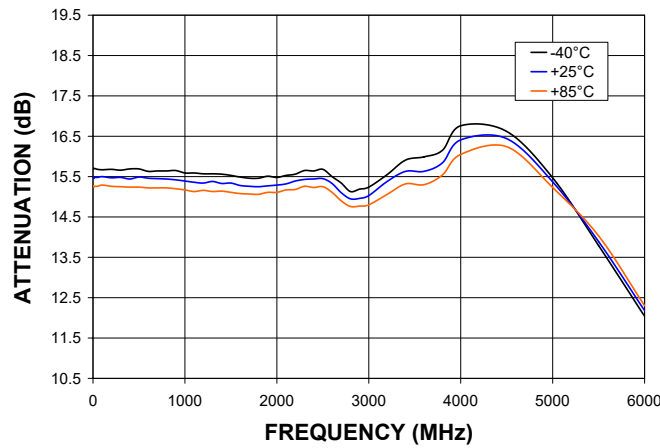

#### RETURN LOSS IN (Ref)

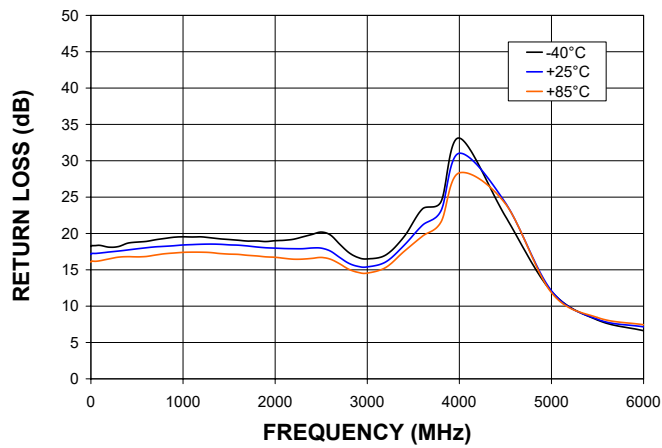

#### RETURN LOSS OUT (Ref)

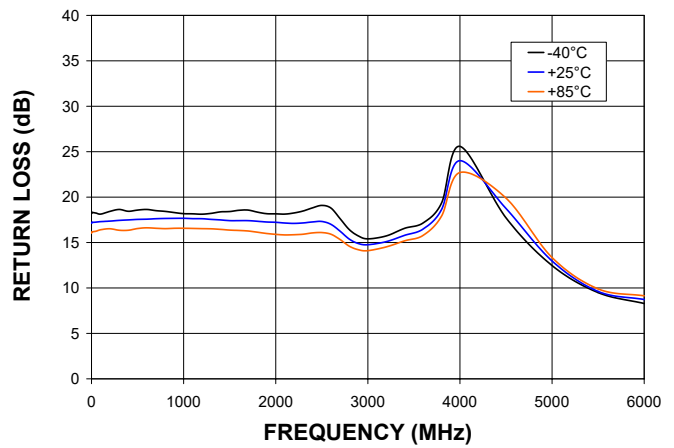

#### RETURN LOSS OUT (Major Atten. Steps) @ +25°C

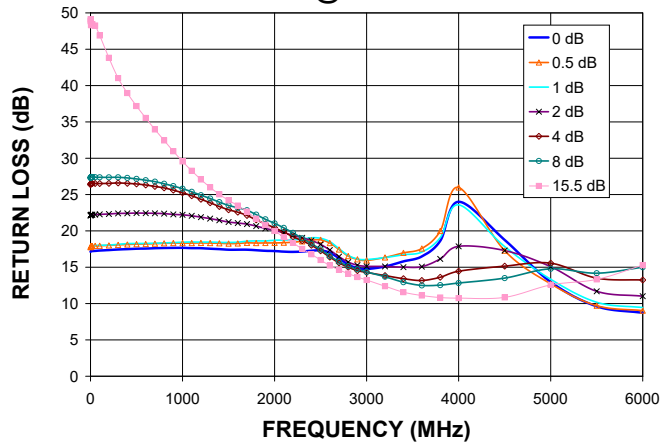

#### RETURN LOSS IN (Major Atten. Steps) @ +25°C

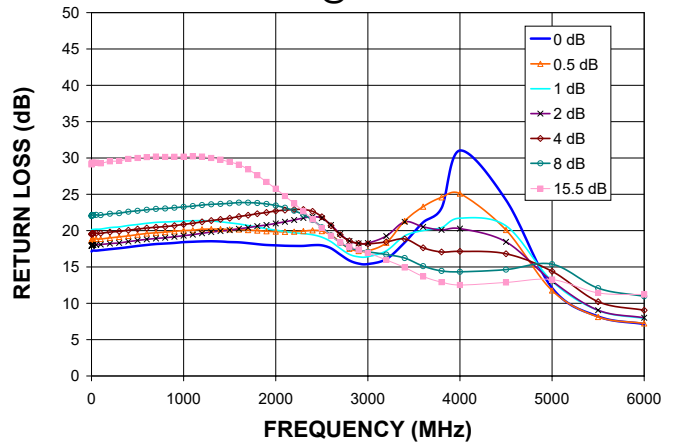

# NON-CATALOG

## Digital Step Attenuator

## ZX76-15R5-PP-S+

### Typical Performance Curves

IP3 (Major Atten. Steps) @ +25°C

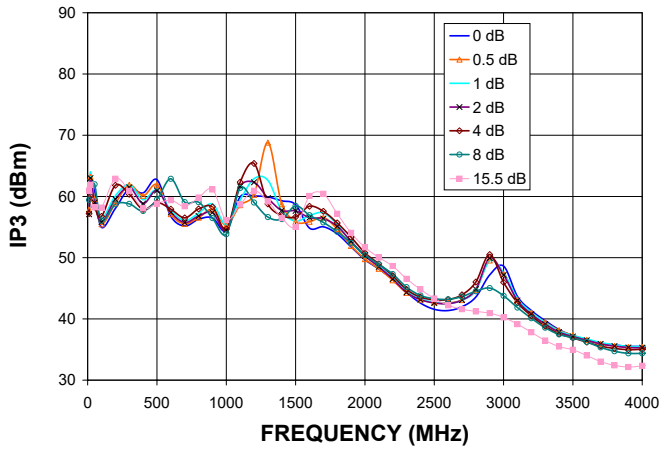

COMPRESSION @ INPUT POWER=+24dBm (Major Atten. Steps) @ +25°C

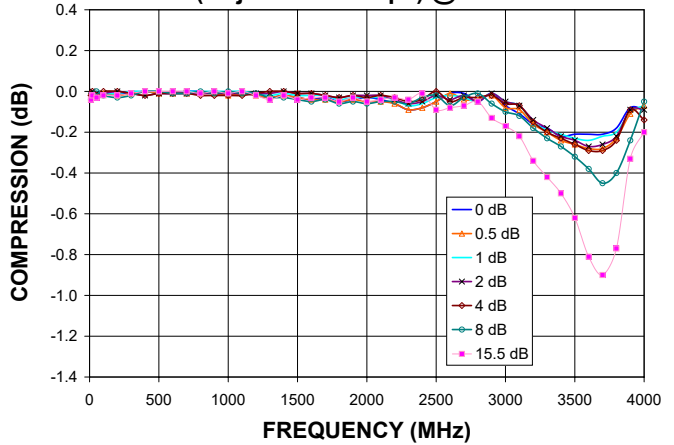

IP3 (Major Atten. Steps) @ -40°C

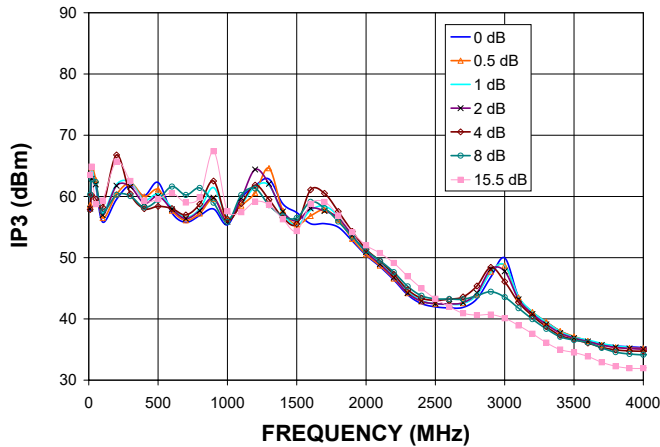

COMPRESSION @ INPUT POWER=+24dBm (Major Atten. Steps) @ -40°C

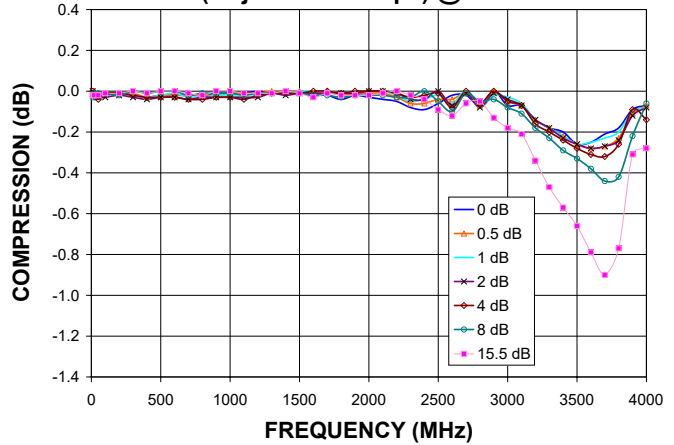

IP3 (Major Atten. Steps) @ +85°C

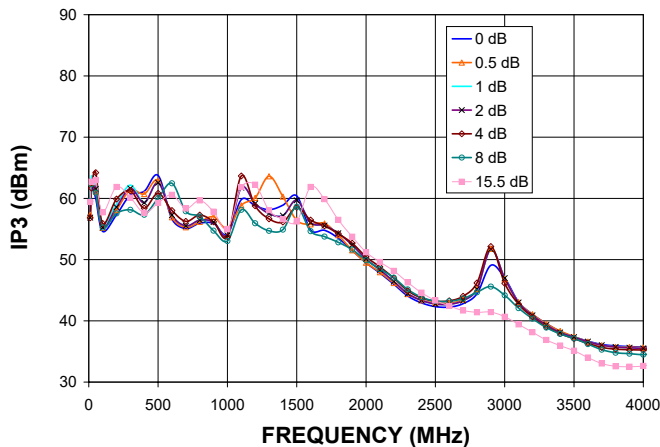

COMPRESSION @ INPUT POWER=+24dBm (Major Atten. Steps) @ +85°C

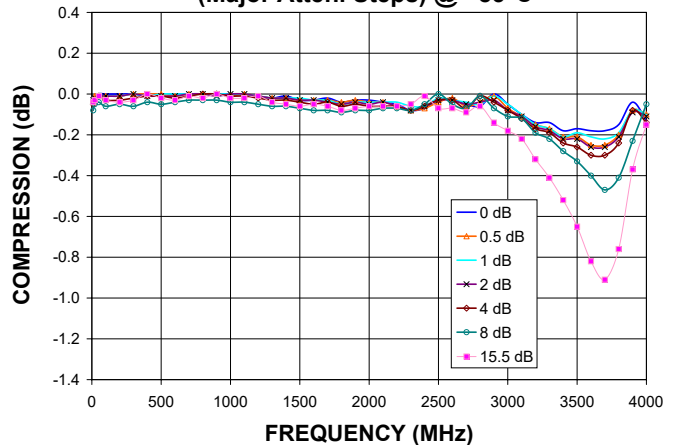

# NON-CATALOG

## Digital Step Attenuator

## ZX76-15R5-PP-S+

### Outline Drawing

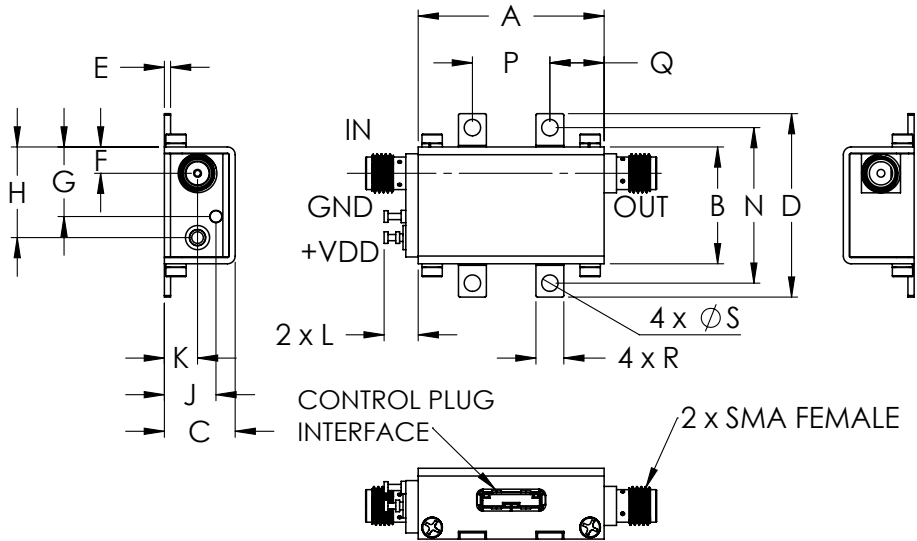

**NOTE:** When soldering the DC connections, caution must be used to avoid overheating the DC terminals. See Application Note [AN-40-10](#).

### Outline Dimensions (inch/mm)

A	B	C	D	E	F	G	H	J	K	L	M	N	P	Q	R	S	WT. GRAMS
1.20	.75	.46	1.18	.04	.17	.45	.59	.33	.21	.22	-	1.00	.50	.35	.18	.106	35
30.48	19.15	11.61	30.07	1.02	4.32	11.40	14.86	8.31	5.44	5.59	-	25.40	12.70	8.89	4.57	2.69	

### Recommended Mounting Hardware:

Use UNC#2 pan head screws with internal tooth lock washers for unit mounting.

### Simplified Schematic

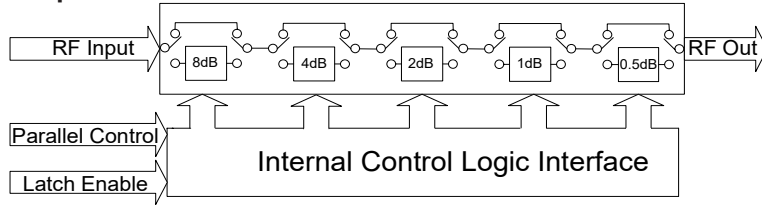

The ZX76-15R5-PP-S+ parallel interface consists of 5 control bits that select the desired attenuation state, as shown in Table 1: Truth Table

Attenuation State	C8	C4	C2	C1	C0.5
Reference	0	0	0	0	0
0.5 (dB)	0	0	0	0	1
1 (dB)	0	0	0	1	0
2 (dB)	0	0	1	0	0
4 (dB)	0	1	0	0	0
8 (dB)	1	0	0	0	0
15.5 (dB)	1	1	1	1	1

Note: Not all 32 possible combinations of C0.5 - C8 are shown in table

The parallel interface timing requirements are defined by Figure 1 (Parallel Interface Timing Diagram) and Table 2 (Parallel Interface AC Characteristics), and switching speed.

For latched parallel programming the Latch Enable (LE) should be held LOW while changing attenuation state control values, then pulse LE HIGH to LOW (per Figure 1) to latch new attenuation state into device.

For direct parallel programming, the Latch Enable (LE) line should be pulled HIGH. Changing attenuation state control values will change device state to new attenuation. Direct mode is ideal for manual control of the device (using hardwire, switches, or jumpers).

Control cables for programming can be ordered separately. For details see page 9.

Figure 1: Parallel Interface Timing Diagram

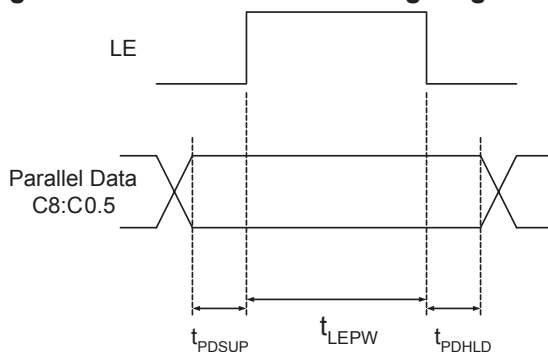

Symbol	Parameter	Min.	Units
$t_{LEPW}$	LE minimum pulse width	10	ns
$t_{PDSUP}$	Data set-up time before clock rising edge of LE	10	ns
$t_{PDHL}$	Data hold time after clock falling edge of LE	10	ns

### Power-up State

When the attenuator powers up and LE is logic low, the nominal attenuation is set on 0 dB. When LE is logic high, the nominal attenuation selected upon control logics ( see Table 1 ).



# NON-CATALOG

## Digital Step Attenuator

## ZX76-15R5-PP-S+

### Recommended Accessories

Two optional cable accessories with and without interface connector are available with ZX76-15R5-PP-S+, the ZX76-CP+ and ZX76-WP+. Cable length is 4.9 feet / 1.5 meters.

ZX76-CP+ shielded cable with interface 25 pin D-type connector and supplied software are used to control the ZX76-15R5-PP-S+ digital attenuator from a computer, using LPT port.

ZX76-WP+ shielded cable without interface 25 pin D-type connector enables customer to use the ZX76-15R5-PP-S+ digital attenuator in his own application.

**ZX76-CP+ Control Cable**

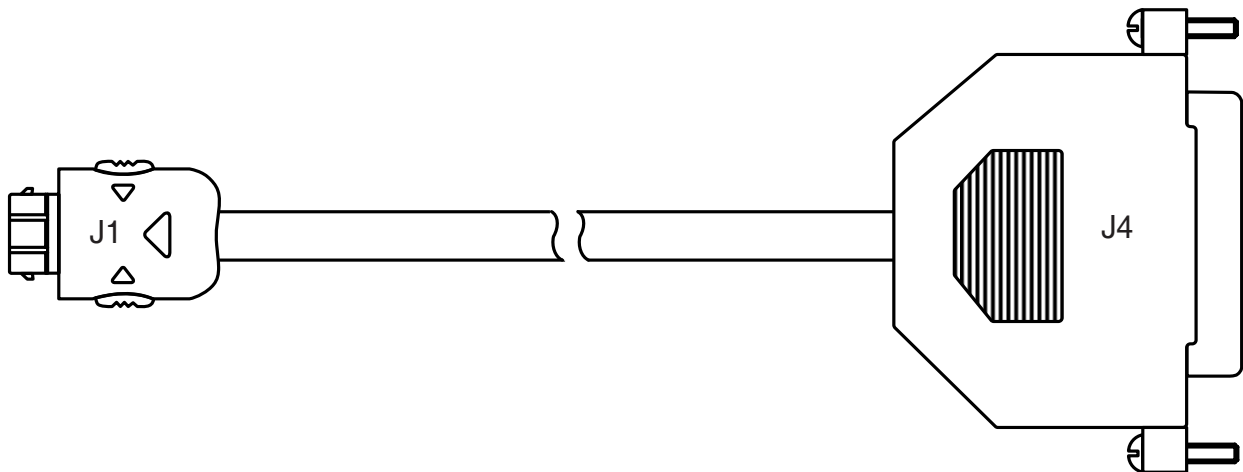

**ZX76-CP+ wiring information**

J1-Pin Number	J4-Pin Number	Function	Description	Wire Color
J1-1	J4-8	LE	Latch Enable Input	WHITE
J1-2	J4-3	C1	Control for attenuation bit, 1 dB	YELLOW
J1-3	J4-2	C0.5	Control for attenuation bit, 0.5 dB	GREEN
J1-5	J4-7	-	Not used	BLUE
J1-6	J4-20	GND	Ground connection	BLACK
J1-8	J4-5	C4	Control for attenuation bit, 4 dB	ORANGE
J1-9	J4-6	C8	Control for attenuation bit, 8 dB	BROWN
J1-10	J4-4	C2	Control for attenuation bit, 2 dB	RED

Note: Other pins not connected. Cable shield connected to case ground.

# NON-CATALOG

## Digital Step Attenuator

## ZX76-15R5-PP-S+

ZX76-WP+ Control Cable

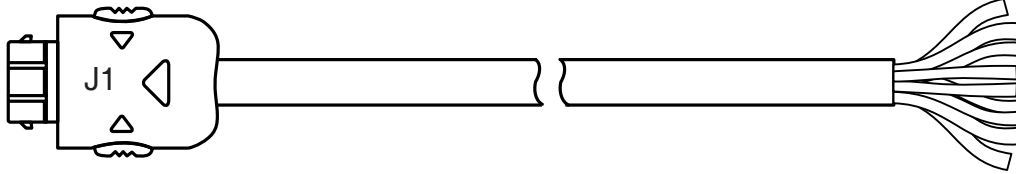

ZX76-WP+ wiring information

Pin Number	Function	Description	Wire Color
J1-1	LE	Latch Enable Input	WHITE
J1-2	C1	Control for attenuation bit, 1 dB	YELLOW
J1-3	C0.5	Control for attenuation bit, 0.5 dB	GREEN
J1-5	-	Not used	BLUE
J1-6	GND	Ground connection	BLACK
J1-8	C4	Control for attenuation bit, 4 dB	ORANGE
J1-9	C8	Control for attenuation bit, 8 dB	BROWN
J1-10	C2	Control for attenuation bit, 2 dB	RED

Note: Other pins not connected. Cable shield connected to case ground.

### Ordering Information

Model Number	Description
ZX76-15R5-PP-S+	Digital attenuator - Parallel interface Single Positive Supply Voltage
ZX76-CP+	Cable accessory with interface connector
ZX76-WP+	Cable accessory without interface connector

### Additional Notes

- Performance and quality attributes and conditions not expressly stated in this specification document are intended to be excluded and do not form a part of this specification document.
- Electrical specifications and performance data contained in this specification document are based on Mini-Circuit's applicable established test performance criteria and measurement instructions.
- The parts covered by this specification document are subject to Mini-Circuits standard limited warranty and terms and conditions (collectively, "Standard Terms"); Purchasers of this part are entitled to the rights and benefits contained therein. For a full statement of the Standard Terms and the exclusive rights and remedies thereunder, please visit Mini-Circuits' website at [www.minicircuits.com/MCLStore/terms.jsp](http://www.minicircuits.com/MCLStore/terms.jsp)



# Digital Step Attenuator

# ZX76-15R5-PP+

## Typical Performance Data

FREQUENCY (MHz)	STEP ATTENUATION* AT TTL CONTROL STATE (dB)						
	00000 THRU LOSS	00001 0.5 dB	00010 1.0 dB	00100 2.0 dB	01000 4.0 dB	10000 8.0 dB	11111 15.5 dB
1	1.31	0.52	1.01	2.02	4.02	7.96	15.50
10	1.33	0.52	1.01	2.02	4.02	7.95	15.46
100	1.36	0.52	1.01	2.03	4.02	7.95	15.50
200	1.37	0.52	1.01	2.03	4.02	7.94	15.47
500	1.44	0.52	1.02	2.04	4.02	7.94	15.49
800	1.53	0.53	1.02	2.05	4.02	7.95	15.44
1000	1.62	0.51	0.99	2.02	4.00	7.91	15.39
1200	1.70	0.50	0.99	2.00	3.97	7.88	15.34
1500	1.80	0.52	1.01	2.03	3.99	7.90	15.34
1700	1.95	0.51	0.99	2.02	3.96	7.84	15.26
2000	2.03	0.52	1.01	2.04	3.99	7.87	15.29
2200	2.05	0.52	1.02	2.09	4.04	7.94	15.39
2500	2.33	0.53	1.05	2.17	4.16	8.02	15.45
3000	2.56	0.58	1.06	2.19	4.12	7.84	15.03
3600	3.17	0.64	1.18	2.35	4.31	8.10	15.63
4000	3.76	0.70	1.22	2.41	4.38	8.30	16.41

\* Step Attenuation above Thru Loss (TTL Logic 00000).

FREQUENCY (MHz)	INPUT RETURN LOSS AT TTL CONTROL STATE (dB)						
	00000 0 dB	00001 0.5 dB	00010 1.0 dB	00100 2.0 dB	01000 4.0 dB	10000 8.0 dB	11111 15.5 dB
1	17.18	18.74	20.10	17.96	19.56	22.06	29.19
10	17.24	18.80	20.14	18.01	19.60	22.13	29.34
100	17.31	18.86	20.22	18.09	19.64	22.14	29.27
200	17.45	19.00	20.42	18.22	19.80	22.33	29.54
500	17.89	19.45	20.85	18.65	20.22	22.73	30.00
800	18.23	19.80	21.19	19.02	20.56	23.05	30.14
1000	18.42	20.01	21.32	19.31	20.86	23.27	30.18
1200	18.52	20.19	21.38	19.64	21.21	23.52	30.19
1500	18.43	20.17	21.07	20.07	21.71	23.76	29.45
1700	18.28	20.08	20.71	20.42	22.12	23.85	28.44
2000	17.98	19.87	20.07	20.99	22.71	23.46	25.77
2200	17.90	19.86	19.70	21.46	22.91	22.74	23.74
2500	17.98	19.94	19.10	21.72	21.91	20.46	20.36
3000	15.40	17.21	16.42	18.29	18.18	17.09	16.95
3600	21.14	23.30	20.02	20.52	17.64	15.12	13.69
4000	31.03	25.10	21.72	20.28	17.15	14.34	12.52

FREQUENCY (MHz)	OUTPUT RETURN LOSS AT TTL CONTROL STATE (dB)						
	00000 0 dB	00001 0.5 dB	00010 1.0 dB	00100 2.0 dB	01000 4.0 dB	10000 8.0 dB	11111 15.5 dB
1	17.18	17.85	17.92	22.17	26.45	27.35	48.86
10	17.22	17.91	17.96	22.23	26.53	27.42	48.30
100	17.30	17.96	18.02	22.28	26.52	27.38	46.89
200	17.36	18.01	18.06	22.33	26.54	27.37	43.82
500	17.55	18.18	18.27	22.46	26.46	27.16	37.18
800	17.65	18.29	18.35	22.38	25.92	26.49	32.45
1000	17.67	18.32	18.44	22.21	25.25	25.81	29.56
1200	17.62	18.34	18.46	21.89	24.35	24.92	27.08
1500	17.41	18.25	18.41	21.22	22.91	23.51	24.21
1700	17.41	18.36	18.58	20.94	22.13	22.85	22.65
2000	17.23	18.35	18.71	20.07	20.43	21.04	19.99
2200	17.11	18.45	18.76	19.39	19.20	19.73	18.34
2500	17.32	18.77	18.99	18.14	17.26	17.44	16.00
3000	14.76	15.94	16.06	15.13	14.29	14.35	13.24
3600	16.49	17.58	17.09	15.08	13.18	12.50	11.11
4000	24.01	25.98	23.59	17.88	14.45	12.83	10.75

REV. X1  
ZX76-15R5-PP+  
061210  
Page 1 of 1



IF/RF MICROWAVE COMPONENTS • ISO 9001 ISO 14001 AS9100 CERTIFIED RoHS compliant  
P.O. Box 350166, Brooklyn, New York 11235-0003 (718) 934-4500 Fax (718) 332-4661



The Design Engineers Search Engine finds the model you need, Instantly • For detailed performance specs & shopping online see



# Digital Step Attenuator

# ZX76-15R5-PP+

## Typical Performance Curves

Thru Loss

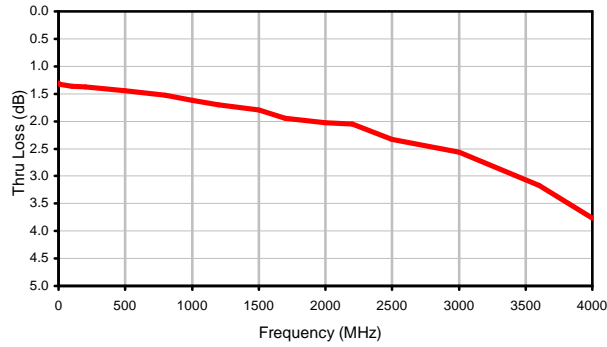

Step Attenuation

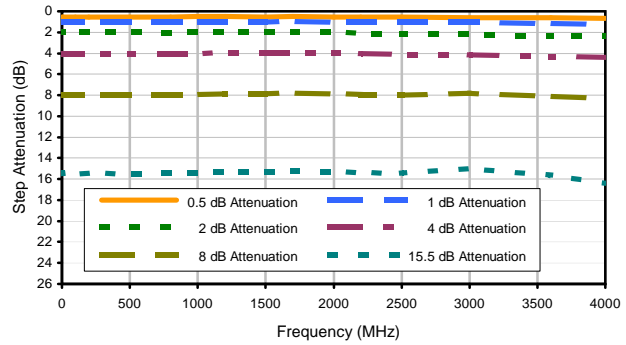

Input Return Loss

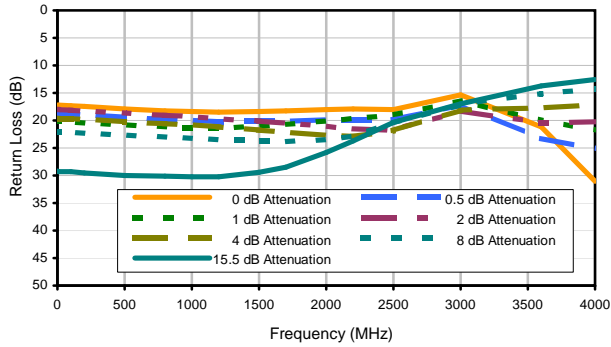

Output Return Loss

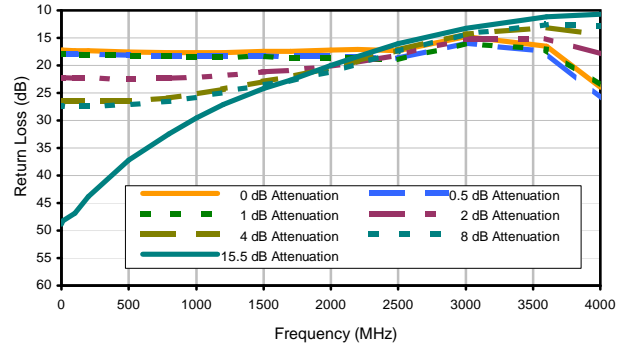

# Case Style

# HK

## Outline Dimensions

## HK1172

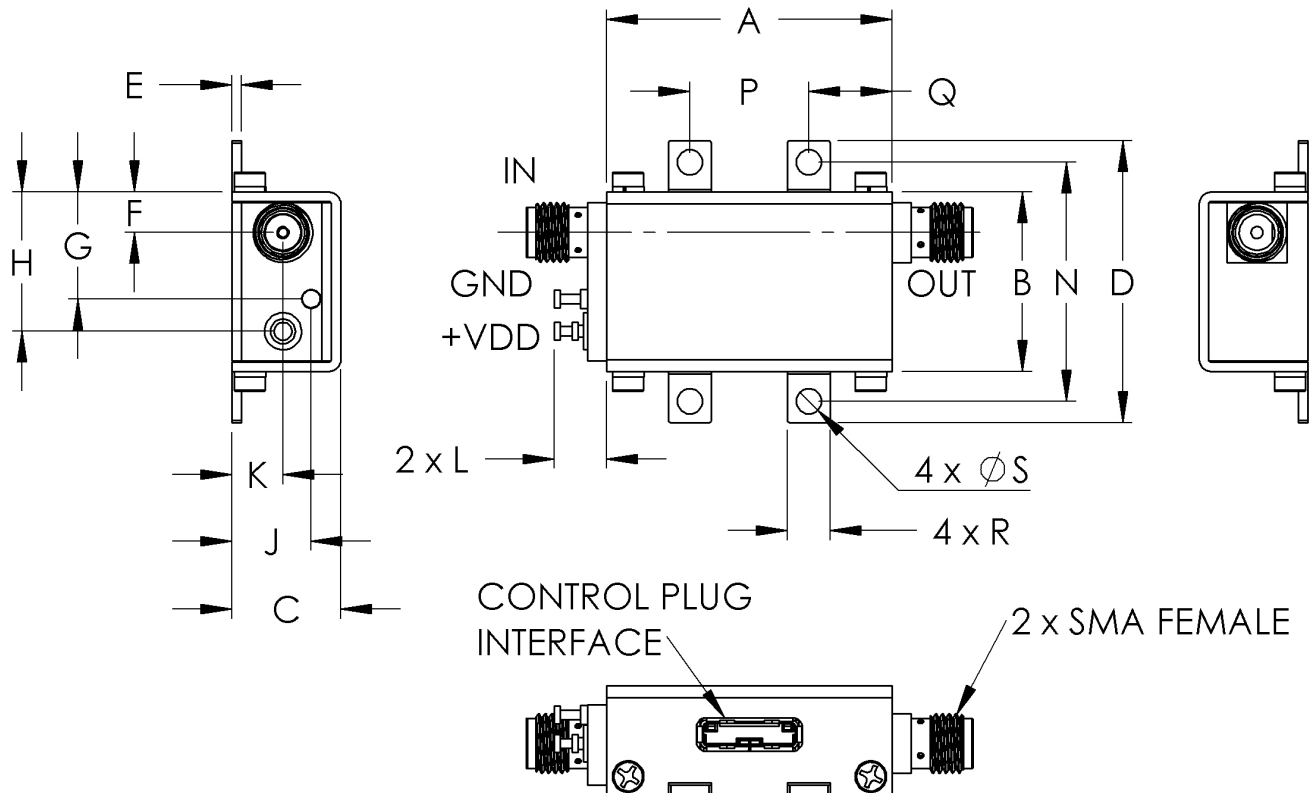

CASE #.	A	B	C	D	E	F	G	H	J	K	L	M	N
HK1172	1.20 (30.48)	.75 (19.15)	.46 (11.61)	1.18 (30.07)	.04 (1.02)	.17 (4.32)	.45 (11.40)	.59 (14.86)	.33 (8.31)	.21 (5.44)	.22 (5.59)	-	1.00 (25.4)

CASE #.	P	Q	R	S	WT GRAMS
HK1172	.50 (12.70)	.35 (8.89)	.18 (4.57)	.106 (2.69)	35

Dimensions are in inches (mm). Tolerances: 2Pl.  $\pm .03$ ; 3Pl.  $\pm .015$   
Tolerance on hole size and interaxes dimensions to be  $\pm .005$ .

### Note:

1. Case material: Brass
2. Case finish: Nickel plate

**Mini-Circuits**<sup>®</sup>

Distribution Centers NORTH AMERICA 800-654-7949 • 417-335-5935 • Fax 417-335-5945 • EUROPE 44-1252-832600 • Fax 44-1252-837010

Mini-Circuits ISO 9001 & ISO 14001 Certified

INTERNET <http://www.minicircuits.com>

P.O. Box 350166, Brooklyn, New York 11235-0003 (718) 934-4500 Fax (718) 332-4661

All Mini-Circuits products are manufactured under exacting quality assurance and control standards, and are capable of meeting published specifications after being subjected to any or all of the following physical and environmental test.

<b>Specification</b>	<b>Test/Inspection Condition</b>	<b>Reference/Spec</b>
Operating Temperature	-40° to 85° C Ambient Environment	Individual Model Data Sheet
Storage Temperature	-40° to 85° C Ambient Environment	Individual Model Data Sheet
Barometric Pressure	100,000 Feet	MIL-STD-202, Method 105, Condition D
Humidity	90% RH, 65°C Units may require bake-out after humidity to restore full performance.	MIL-STD-202, Method 103
Thermal Shock	-65° to 125°C, 5 cycles	MIL-STD-202, Method 107, Condition B
Vibration (High Frequency)	20g peak, 10-2000 Hz, 12 times in each of three perpendicular directions (total 36)	MIL-STD-202, Method 204, Condition D
Mechanical Shock	100g, 6ms sawtooth, 3 shocks each direction 3 axes (total 18)	MIL-STD-202, Method 213, Condition I