



COAXIAL WIDEBAND

Digital Step Attenuator **ZX76-44G-30-K+**

50Ω 0 to 31.5 dB, 0.5 dB Step 100 MHz to 43.5 GHz
6 Bit, Parallel Control Interface, Dual or Single Supply Voltage

THE BIG DEAL

- Wideband, Operates Up to 43.5 GHz
- Immune to Latch-Up
- High IIP3, +50 dBm
- Low Insertion Loss
- Good VSWR, 1.5:1 Typ.
- Glitch-Less Attenuation Transitions
- Dual +3.3, -3 V or Single Supply Voltage +3.3 V



Generic photo used for illustration purposes only

Model No.	ZX76-44G-30-K+
Case Style	MS3009
Connectors	2.92 mm female

+RoHS Compliant

The +Suffix identifies RoHS Compliance.
See our website for methodologies and qualifications

APPLICATIONS

- Test Setup
- 5G
- Satellite Communications
- X Band, S Band, C Band, KU Band, and K Band Radars
- EW Test Sets

PRODUCT OVERVIEW

The ZX76-44G-30-K+ is a 50Ω Digital Step Attenuator that provides adjustable attenuation from 0 to 31.5 dB in 0.5 dB steps. The control is a 6-bit parallel interface, with a single positive supply voltage. The model is produced using a unique unibody case package for ruggedness and operation in tough environments.

KEY FEATURES

Feature	Advantages
Wideband Operation, Specified from 100 MHz to 43.5 GHz	Can be used in multiple applications such as communications, satellite and defense, reducing part count. Able to work up to 43.5 GHz.
Parallel Control Interface with Wide Control Voltage Range	Uses a simple parallel control interface with no clock required.
Good VSWR, 1.5:1 Typ.	Eases interfacing with adjacent components and results in low amplitude ripple.
Glitch-Less Attenuation Transitions	The ZX76-44G-30-K+ employs novel architecture to reduce the RF output power spikes during attenuation transition to 0.3 dB (typ.) thus reducing noise in the system and eliminating the risk of a transient spike damaging sensitive components in the system.
Positive and Negative Power Supply, Single Positive Supply Is Available	The use of a single positive supply simplifies power supply design. An internal negative voltage generator supplies the desired negative voltage. Single positive supply results in excellent spurious performance. For applications that require the lowest possible spur performance negative voltage can be applied externally to bypass the internal negative voltage generator.
Power Supply +2.3 V to +5.5 V	Model suitable for both +5 V and +3.3 V systems applications with no voltage dividers or multipliers needed.



COAXIAL WIDEBAND

Digital Step Attenuator **ZX76-44G-30-K+**

50Ω 0 to 31.5 dB, 0.5 dB Step 100 MHz to 43.5 GHz
6 Bit, Parallel Control Interface, Dual or Single Supply Voltage

RF ELECTRICAL SPECIFICATIONS, 100 MHz - 43.5 GHz, $T_{AMB} = +25\text{ }^{\circ}\text{C}$, $V_{DD} = +3.3\text{ V}$

Parameter	Frequency (GHz)	Min.	Typ.	Max.	Units
Insertion Loss at 0 dB Attenuation Setting	0.1-13		3.0	7.0	dB
	13- 26.5		5.5	8.5	
	26.5-43.5		7.5	11.5	
Input IP3 ¹	2-16		+50		dBm
Input Power at 1 dB Compression	0.1-43.5	+22			dBm
VSWR	0.1-26.5		1.3		:1
	26.5-43.5		1.5		

1. Tested with 1 MHz offset between signals.

ATTENUATION ACCURACY AT +25 °C

Attenuation Setting	Nominal Attenuation (Typ.)			Typical Attenuation Accuracy		
	13 GHz	26.5 GHz	43.5 GHz	13 GHz	26.5 GHz	43.5 GHz
0.5 dB	0.45	0.28	0.33	±0.04	±0.22	±0.17
1 dB	0.85	0.70	0.45	±0.13	±0.30	±0.55
2 dB	2.2	2.5	2.8	±0.16	±0.49	±0.75
4 dB	4.2	4.1	4.0	±0.16	±0.11	±0.05
8 dB	8.2	8.5	8.4	±0.17	±0.46	±0.35
16 dB	16.4	16.5	17.1	±0.41	±0.49	±1.06
31.5 dB	32.0	32.0	31.8	±0.54	±0.54	±0.26

DC ELECTRICAL SPECIFICATIONS

Parameter	Min.	Typ.	Max.	Units
Positive Supply Voltage, V_{DD}	+2.3	+3.3	+5.5	V
Positive Supply Current, I_{DD}		170	250	μA
Negative Supply Voltage, V_{SS}	-3.3	-3.0	-2.7	V
Negative Supply Current, I_{SS}	-40	-16		μA
Control Input Low	-0.3		+0.6	V
Control Input High	+1.17		+3.5	V
Control Current		10	20	μA

SWITCHING SPECIFICATIONS

Parameter	Min.	Typ.	Max.	Units
Switching Speed, 50% Control to 0.5 dB of Attenuation Value		330	400	nsec

ABSOLUTE MAXIMUM RATINGS

Parameter	Ratings
Operating Temperature	0 °C to +50 °C
Storage Temperature	-20 °C to +85 °C
V_{DD}	-0.3 V Min., +6 V Max.
V_{SS}	-3.6 V Min., +0.3 V Max.
Voltage On Any Control Input	-0.3 V Min., +3.6 V Max.
ESD, HBM	1000 V
Maximum Input Power ²	+28 dBm

Permanent damage may occur if any of these limits are exceeded. Operating in the range between operating power limits and absolute maximum ratings for extended periods of time may result in reduced life and reliability.

2. $T_{AMBIENT} = +25\text{ }^{\circ}\text{C}$, derate to +26 dBm at +50 °C



COAXIAL WIDEBAND

Digital Step Attenuator **ZX76-44G-30-K+**

50Ω 0 to 31.5 dB, 0.5 dB Step 100 MHz to 43.5 GHz
6 Bit, Parallel Control Interface, Dual or Single Supply Voltage

PIN CONFIGURATION (TOP VIEW)

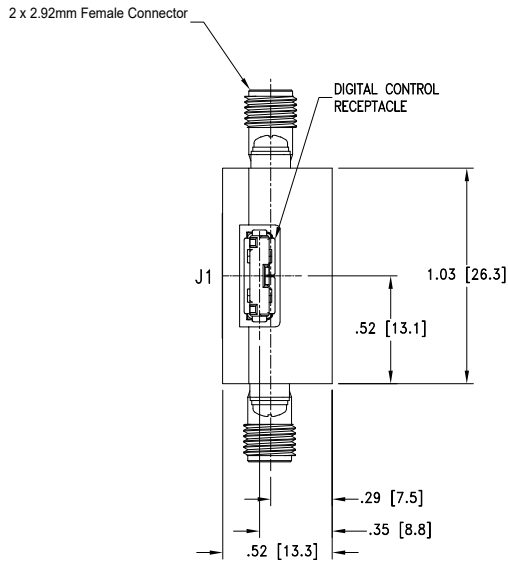
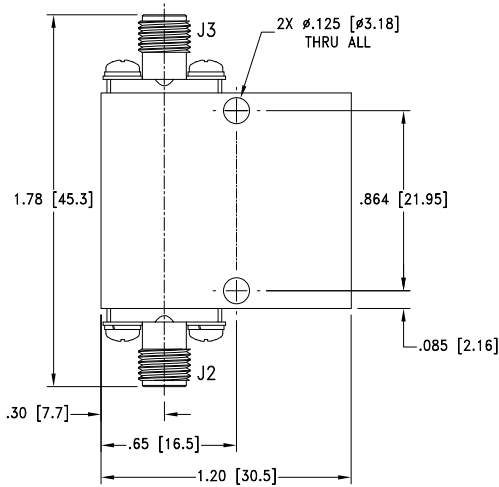

PIN DESCRIPTION

Function	Pin Number	Description
LE	J1-1	Latch Enable Input
\bar{P}/S	J1-2	Logic Low (0 V) ³
C0.5	J1-3	Control for attenuation bit, 0.5 dB
C1	J1-4	Control for attenuation bit, 1.0 dB
C4	J1-5	Control for attenuation bit, 4.0 dB
C2	J1-6	Control for attenuation bit, 2 dB
C8	J1-7	Control for attenuation bit, 8 dB
C16	J1-8	Control for attenuation bit, 16 dB
V _{DD}	J1-9	Positive Supply Voltage
V _{SS}	J1-10	Negative Supply Voltage ⁴ (or ext. gnd.)
IN	J2	RF in port ⁵
OUT	J3	RF out port ⁵

3. J1-2 Must be tied low before applying any control bit.

4. If Pin J1-10 is grounded the internal negative voltage will be generated.

5. Both RF ports are DC blocked with an internal series capacitors.



Digital Step Attenuator ZX76-44G-30-K+

50Ω 0 to 31.5 dB, 0.5 dB Step 100 MHz to 43.5 GHz
6 Bit, Parallel Control Interface, Dual or Single Supply Voltage

SIMPLIFIED SCHEMATIC

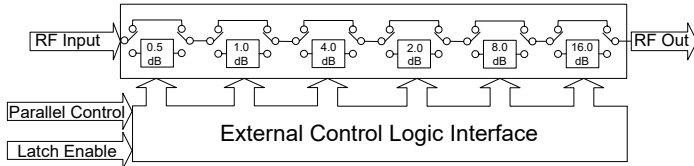

The ZX76-44G-30-K+ parallel interface consists of 6 control bits that select the desired attenuation state, as shown in Table 1: Truth Table.

TABLE 1. TRUTH TABLE

Attenuation State	C16	C8	C4	C2	C1	C0.5
Reference	0	0	0	0	0	0
0.5 (dB)	0	0	0	0	0	1
1 (dB)	0	0	0	0	1	0
2 (dB)	0	0	0	1	0	0
4 (dB)	0	0	1	0	0	0
8 (dB)	0	1	0	0	0	0
16 (dB)	1	0	0	0	0	0
31.5 (dB)	1	1	1	1	1	1

Note: Not all 64 possible combinations of C0.5 - C16 are shown in table.

The parallel interface timing requirements are defined by Figure 1 (Parallel Interface Timing Diagram) and Table 2 (Parallel Interface AC Characteristics), and the switching speed.

For latched parallel programming the Latch Enable (LE) should be held LOW while changing attenuation state control values, then pulse LE HIGH to LOW (per Figure 1) to latch new attenuation state into the device.

For direct parallel programming, the Latch Enable (LE) line should be pulled HIGH. Changing the attenuation state control values will immediately change the device's state to a new attenuation value. Direct mode is ideal for manual control of the device (using hardware, switches, or jumpers).

TABLE 2. PARALLEL INTERFACE AC CHARACTERISTICS

Symbol	Parameter	Min.	Units
t_{LEPW}	LE minimum pulse width	30	ns
t_{PDSUP}	Data set-up time before clock rising edge of LE	100	ns
t_{PDHLD}	Data hold time after clock falling edge of LE	100	ns

FIGURE 1: PARALLEL INTERFACE TIMING DIAGRAM

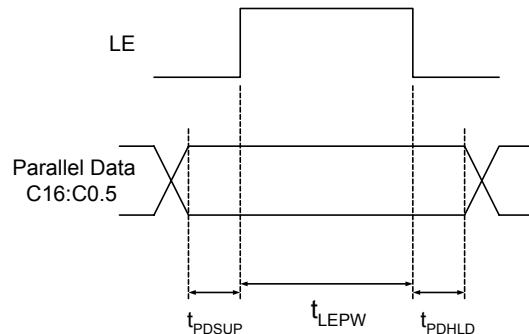

POWER-UP STATE

When the attenuator powers up and LE is logic low, the maximum attenuation is set to 31.5 dB. When LE is logic high, the nominal attenuation selected upon control logics (see Table 1). When LE is logic HIGH upon turn on, the start-up attenuation value will be set based on the control logic in Table 1.



COAXIAL WIDEBAND

Digital Step Attenuator **ZX76-44G-30-K+**

50Ω 0 to 31.5 dB, 0.5 dB Step 100 MHz to 43.5 GHz
6 Bit, Parallel Control Interface, Dual or Single Supply Voltage

CBL-5FT-MPD+ CONTROL CABLE

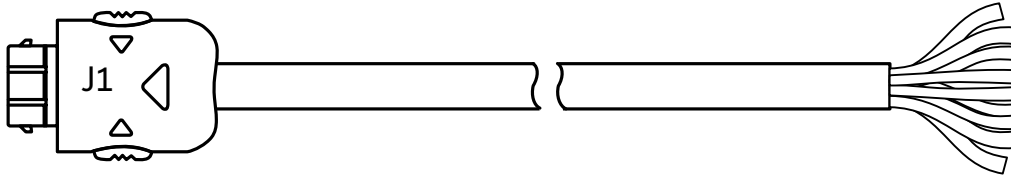

INCLUDED ACCESSORIES

CBL-5FT-MPD+ is a "Pigtail" connector included with every purchase of ZX76-44G-30-K+. CBL-5FT-MPD+ is a shielded cable with stripped wires (#32 AWG) on one end and a connector on the other end designed to mate to the ZX76-44G-30-K+. These bare wires enable the customer to assemble their own cable as required to interface with the ZX76-44G-30-K+ (cable length is 4.9 ft/ 1.5 meters).

CBL-5FT-MPD+ WIRING INFORMATION

J1 Pin Number	Function	Description	Wire Color
1	LE	Latch Enable Input	Green
2	\bar{P}/S	Logic Low (0 V)	Green/Black
3	C0.5	Control for attenuation bit, 0.5 dB	Red
4	C1	Control for attenuation bit, 1.0 dB	Orange
5	C4	Control for attenuation bit, 4.0 dB	Orange/Black
6	C2	Control for attenuation bit, 2.0 dB	Black
7	C8	Control for attenuation bit, 8.0 dB	Red/Black
8	C16	Control for attenuation bit, 16.0 dB	Blue
9	V _{DD}	Positive Supply Voltage	White
10	V _{SS}	Negative Supply Voltage (or ext. ground)	White/Black
Shield	-	Shield Braid/Drain	-

Note: Cable shield connected to case ground.



COAXIAL WIDEBAND

Digital Step Attenuator **ZX76-44G-30-K+**

50Ω 0 to 31.5 dB, 0.5 dB Step 100 MHz to 43.5 GHz
6 Bit, Parallel Control Interface, Dual or Single Supply Voltage

TYPICAL PERFORMANCE DATA

Frequency (MHz)	Insertion loss (dB)	Attenuation Relative to Insertion Loss @ Attenuation Settings						
		0.5 dB	1 dB	2 dB	4 dB	8 dB	16 dB	32 dB
100	1.41	0.49	0.90	2.20	4.21	8.13	16.23	32.10
500	1.51	0.49	0.91	2.18	4.22	8.15	16.25	32.12
1000	1.61	0.49	0.92	2.17	4.22	8.15	16.26	32.13
5000	2.32	0.44	0.84	2.26	4.15	8.06	16.15	32.00
10000	3.43	0.45	0.85	2.23	4.11	8.10	16.25	31.96
13000	3.67	0.46	0.87	2.16	4.16	8.17	16.41	32.04
15000	3.92	0.41	0.80	2.21	4.09	8.11	16.34	31.95
20000	4.64	0.37	0.74	2.23	4.02	8.14	16.39	31.91
25000	5.65	0.30	0.68	2.34	4.00	8.25	16.37	31.92
26000	5.78	0.28	0.70	2.43	4.07	8.38	16.44	32.00
30000	6.09	0.30	0.65	2.48	3.95	8.26	16.44	31.77
35000	6.17	0.29	0.71	2.46	4.06	8.59	16.83	32.12
40000	7.65	0.27	0.50	2.48	3.79	8.01	16.39	31.46
43500	7.82	0.33	0.45	2.75	3.95	8.35	17.06	31.76

Frequency (MHz)	VSWR In (:1) @ Attenuation Settings								VSWR Out (:1) @ Attenuation Settings							
	0 dB	0.5 dB	1 dB	2 dB	4 dB	8 dB	16 dB	32 dB	0 dB	0.5 dB	1 dB	2 dB	4 dB	8 dB	16 dB	32 dB
100	1.33	1.21	1.10	1.69	1.24	1.01	1.03	1.03	1.31	1.21	1.13	1.57	1.05	1.18	1.03	1.05
500	1.35	1.23	1.12	1.70	1.25	1.02	1.03	1.03	1.33	1.23	1.16	1.59	1.06	1.19	1.04	1.05
1000	1.35	1.23	1.12	1.70	1.25	1.03	1.04	1.04	1.34	1.23	1.17	1.59	1.07	1.20	1.05	1.05
5000	1.22	1.13	1.05	1.54	1.19	1.03	1.04	1.04	1.23	1.15	1.12	1.46	1.06	1.20	1.06	1.03
10000	1.14	1.12	1.12	1.35	1.12	1.20	1.22	1.22	1.17	1.17	1.22	1.21	1.10	1.16	1.19	1.18
13000	1.20	1.16	1.22	1.29	1.10	1.21	1.21	1.22	1.21	1.14	1.11	1.36	1.17	1.13	1.08	1.17
15000	1.22	1.16	1.17	1.41	1.14	1.08	1.07	1.07	1.25	1.20	1.21	1.39	1.17	1.27	1.07	1.09
20000	1.18	1.23	1.30	1.12	1.16	1.29	1.28	1.29	1.06	1.09	1.13	1.08	1.09	1.12	1.24	1.15
25000	1.83	1.87	1.99	1.40	1.61	1.77	1.72	1.70	1.54	1.48	1.41	1.67	1.58	1.42	1.43	1.54
26000	1.78	1.81	1.93	1.48	1.65	1.82	1.78	1.76	1.53	1.47	1.45	1.72	1.67	1.58	1.44	1.62
30000	1.39	1.34	1.28	1.70	1.41	1.34	1.36	1.35	1.65	1.68	1.74	1.43	1.53	1.57	1.43	1.45
35000	1.08	1.09	1.13	1.24	1.10	1.20	1.21	1.19	1.22	1.25	1.25	1.08	1.17	1.16	1.18	1.15
40000	1.71	1.66	1.54	1.92	1.55	1.38	1.36	1.37	1.78	1.81	1.77	1.54	1.62	1.47	1.55	1.47
43500	1.31	1.33	1.26	1.49	1.35	1.23	1.23	1.25	1.35	1.38	1.32	1.52	1.43	1.53	1.76	1.54





COAXIAL WIDEBAND

Digital Step Attenuator **ZX76-44G-30-K+**

50Ω 0 to 31.5 dB, 0.5 dB Step 100 MHz to 43.5 GHz
6 Bit, Parallel Control Interface, Dual or Single Supply Voltage

Insertion Loss

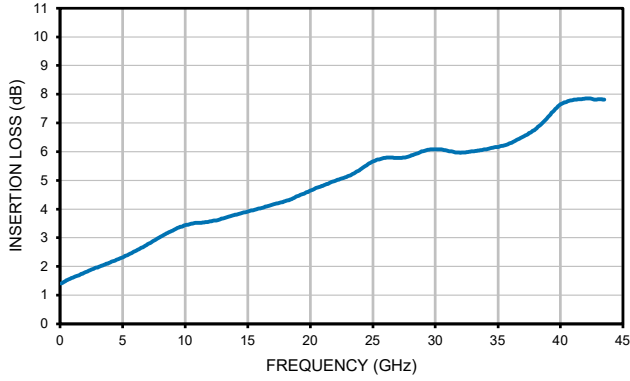

Attenuation relative to Insertion Loss over Attenuation Settings

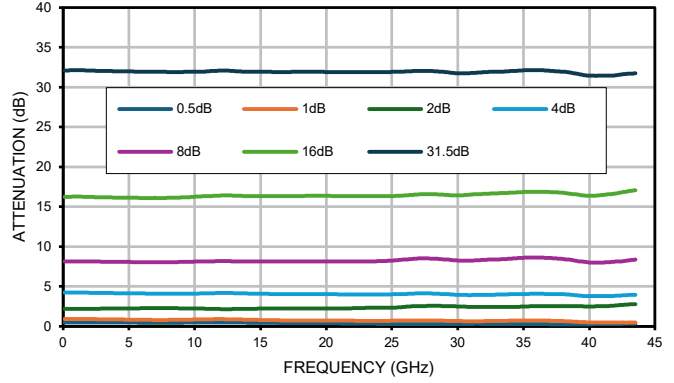

Input VSWR over Attenuation Settings

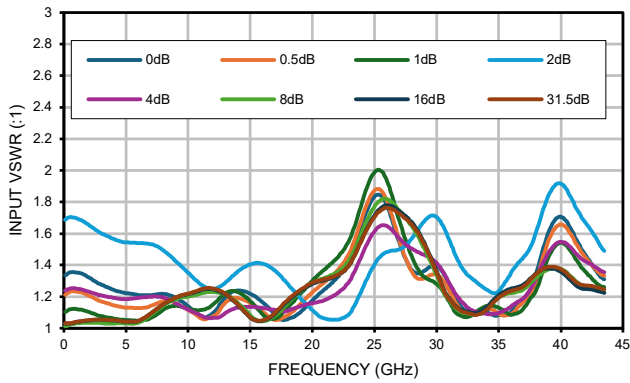

Output VSWR over Attenuation Settings

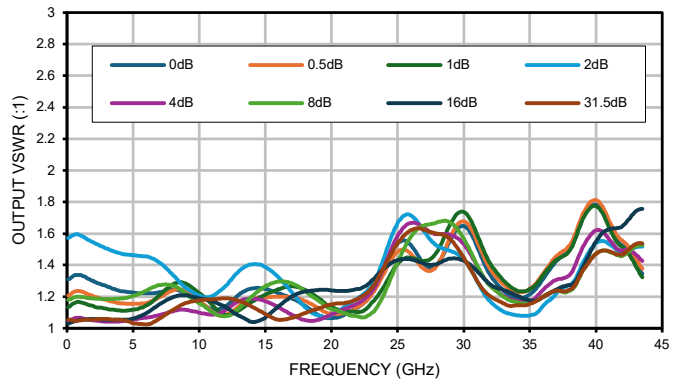



COAXIAL WIDEBAND

Digital Step Attenuator **ZX76-44G-30-K+**

50Ω 0 to 31.5 dB, 0.5 dB Step 100 MHz to 43.5 GHz
6 Bit, Parallel Control Interface, Dual or Single Supply Voltage

ADDITIONAL DETAILED INFORMATION IS AVAILABLE ON OUR DASHBOARD [CLICK HERE](#)

Performance Data & Graphs	Data Graphs S-Parameter (S2P Files) Data Set (.zip file)
Case Style	MS3009
RoHS Status	Compliant
Environmental Ratings	ENV28T14
Export Info	EAR99

INCLUDED ACCESSORY

Photo	
Part No.	CBL-5FT-MPD+
Description	5 ft. (1.5 m) Control Cable
Quantity	1

- NOTES**
- A. Performance and quality attributes and conditions not expressly stated in this specification document are intended to be excluded and do not form a part of this specification document.
 - B. Electrical specifications and performance data contained in this specification document are based on Mini-Circuit's applicable established test performance criteria and measurement instructions.
 - C. The parts covered by this specification document are subject to Mini-Circuits standard limited warranty and terms and conditions (collectively, "Standard Terms"); Purchasers of this part are entitled to the rights and benefits contained therein. For a full statement of the standard. Terms and the exclusive rights and remedies thereunder, please visit Mini-Circuits' website at www.minicircuits.com/terms/viewterm.html



Wide Band Digital Step Attenuation

ZX76-44G-30-K+

Typical Performance Data

Frequency (GHz)	Insertion Loss (dB)	Attenuation relative to Insertion Loss						
		(dB)						
		@ Attenuation Setting						
	0 dB	.5 dB	1.0 dB	2.0 dB	4.0 dB	8.0 dB	16 dB	31.5 dB
0.1	1.33	0.48	0.90	2.16	4.20	8.13	16.23	32.09
0.2	1.39	0.48	0.91	2.16	4.21	8.14	16.24	32.11
0.3	1.43	0.48	0.91	2.15	4.21	8.15	16.25	32.12
0.4	1.46	0.48	0.92	2.14	4.22	8.15	16.26	32.13
0.5	1.48	0.49	0.92	2.14	4.22	8.16	16.27	32.14
0.6	1.50	0.49	0.92	2.14	4.22	8.16	16.27	32.15
0.7	1.52	0.49	0.93	2.14	4.22	8.17	16.28	32.15
0.8	1.54	0.49	0.93	2.13	4.23	8.17	16.28	32.16
0.9	1.56	0.49	0.93	2.13	4.23	8.17	16.29	32.16
1.0	1.57	0.49	0.93	2.13	4.23	8.17	16.29	32.16
2.0	1.76	0.48	0.91	2.15	4.21	8.14	16.25	32.13
3.0	1.95	0.45	0.86	2.21	4.16	8.09	16.18	32.05
4.0	2.13	0.44	0.85	2.23	4.15	8.07	16.16	32.02
5.0	2.25	0.45	0.86	2.21	4.16	8.08	16.20	32.06
6.0	2.45	0.43	0.83	2.24	4.14	8.06	16.17	32.04
7.0	2.70	0.42	0.80	2.28	4.12	8.04	16.14	31.98
8.0	2.97	0.43	0.82	2.25	4.11	8.05	16.17	31.94
9.0	3.17	0.44	0.85	2.21	4.12	8.09	16.24	31.99
10.0	3.34	0.46	0.88	2.17	4.12	8.13	16.31	32.03
11.0	3.41	0.48	0.92	2.12	4.15	8.19	16.42	32.10
12.0	3.41	0.49	0.94	2.08	4.18	8.25	16.52	32.20
13.0	3.50	0.46	0.90	2.10	4.15	8.20	16.50	32.17
14.0	3.61	0.43	0.85	2.14	4.10	8.15	16.43	32.13
15.0	3.69	0.42	0.83	2.17	4.09	8.14	16.44	32.13
16.0	3.77	0.42	0.81	2.17	4.09	8.14	16.47	32.16
17.0	3.88	0.40	0.79	2.19	4.08	8.14	16.48	32.19
18.0	4.04	0.39	0.78	2.20	4.06	8.15	16.48	32.19
19.0	4.20	0.40	0.78	2.19	4.07	8.16	16.55	32.24
20.0	4.41	0.41	0.78	2.15	4.08	8.19	16.65	32.36
21.0	4.64	0.38	0.75	2.12	4.03	8.16	16.60	32.36
22.0	4.75	0.34	0.72	2.19	4.01	8.16	16.51	32.30
23.0	4.78	0.32	0.71	2.26	4.04	8.23	16.51	32.29
24.0	5.06	0.32	0.72	2.23	4.02	8.26	16.54	32.29
25.0	5.49	0.29	0.72	2.25	4.04	8.33	16.54	32.32
26.0	5.53	0.27	0.75	2.43	4.20	8.56	16.67	32.44
27.0	5.44	0.27	0.74	2.53	4.24	8.62	16.69	32.35
28.0	5.54	0.27	0.71	2.53	4.17	8.53	16.60	32.10
29.0	5.84	0.27	0.68	2.52	4.11	8.42	16.47	31.82
30.0	6.18	0.28	0.61	2.45	3.93	8.14	16.22	31.37
31.0	6.06	0.31	0.59	2.40	3.87	8.07	16.26	31.23
32.0	5.84	0.32	0.64	2.36	3.91	8.20	16.41	31.33
33.0	5.95	0.31	0.66	2.35	3.94	8.28	16.46	31.34
34.0	6.13	0.31	0.63	2.37	3.91	8.24	16.47	31.29
35.0	6.09	0.31	0.63	2.36	3.91	8.30	16.59	31.41
36.0	6.04	0.30	0.68	2.33	3.97	8.44	16.71	31.68
37.0	6.10	0.29	0.70	2.36	4.03	8.52	16.76	31.96
38.0	6.50	0.28	0.63	2.36	3.94	8.35	16.62	32.01
39.0	7.00	0.29	0.56	2.35	3.82	8.14	16.50	31.88
40.0	7.17	0.31	0.52	2.40	3.81	8.13	16.61	31.90
41.0	7.05	0.32	0.53	2.44	3.85	8.26	16.82	31.88
42.0	7.06	0.31	0.52	2.45	3.86	8.29	16.85	31.68
43.0	7.26	0.32	0.48	2.53	3.87	8.27	16.86	31.34
43.5	7.36	0.34	0.46	2.59	3.90	8.32	16.95	31.24

Wide Band Digital Step Attenuation

ZX76-44G-30-K+

Typical Performance Data

Frequency (GHz)	Input VSWR (:1)							
	@ Attenuation Setting							
	0 dB	0.5 dB	1.0 dB	2.0 dB	4.0 dB	8.0 dB	16 dB	31.5 dB
0.1	1.31	1.20	1.13	1.56	1.03	1.16	1.01	1.08
0.2	1.33	1.22	1.14	1.57	1.04	1.17	1.02	1.08
0.3	1.34	1.23	1.15	1.58	1.05	1.17	1.03	1.08
0.4	1.34	1.23	1.16	1.58	1.06	1.18	1.03	1.08
0.5	1.34	1.23	1.16	1.58	1.06	1.18	1.04	1.08
0.6	1.35	1.24	1.17	1.58	1.06	1.18	1.04	1.08
0.7	1.35	1.24	1.17	1.58	1.06	1.18	1.05	1.09
0.8	1.35	1.24	1.17	1.58	1.06	1.18	1.05	1.09
0.9	1.35	1.24	1.17	1.58	1.06	1.18	1.06	1.09
1.0	1.34	1.24	1.17	1.57	1.06	1.18	1.06	1.09
2.0	1.32	1.22	1.15	1.55	1.05	1.19	1.05	1.07
3.0	1.30	1.21	1.16	1.56	1.08	1.24	1.08	1.03
4.0	1.28	1.21	1.19	1.50	1.07	1.26	1.12	1.06
5.0	1.22	1.16	1.15	1.42	1.02	1.21	1.10	1.08
6.0	1.18	1.12	1.13	1.39	1.02	1.20	1.07	1.06
7.0	1.23	1.21	1.24	1.38	1.06	1.28	1.14	1.07
8.0	1.29	1.30	1.35	1.31	1.13	1.30	1.23	1.16
9.0	1.23	1.24	1.30	1.23	1.11	1.23	1.22	1.20
10.0	1.20	1.20	1.25	1.23	1.07	1.19	1.19	1.18
11.0	1.18	1.16	1.20	1.23	1.06	1.16	1.17	1.18
12.0	1.16	1.10	1.12	1.27	1.11	1.12	1.15	1.20
13.0	1.22	1.15	1.13	1.36	1.19	1.15	1.08	1.19
14.0	1.26	1.20	1.22	1.39	1.19	1.29	1.04	1.12
15.0	1.27	1.25	1.31	1.34	1.13	1.36	1.15	1.04
16.0	1.24	1.25	1.32	1.25	1.08	1.35	1.20	1.04
17.0	1.22	1.24	1.32	1.20	1.07	1.34	1.23	1.05
18.0	1.28	1.32	1.40	1.20	1.12	1.40	1.32	1.13
19.0	1.31	1.38	1.45	1.17	1.19	1.40	1.45	1.26
20.0	1.21	1.28	1.32	1.13	1.23	1.30	1.51	1.36
21.0	1.23	1.24	1.20	1.27	1.31	1.16	1.47	1.40
22.0	1.29	1.27	1.18	1.34	1.34	1.10	1.37	1.37
23.0	1.22	1.21	1.14	1.29	1.29	1.07	1.32	1.31
24.0	1.38	1.35	1.26	1.45	1.43	1.20	1.45	1.45
25.0	1.66	1.60	1.50	1.77	1.73	1.48	1.56	1.69
26.0	1.50	1.44	1.42	1.68	1.73	1.61	1.48	1.72
27.0	1.26	1.24	1.31	1.45	1.56	1.59	1.34	1.60
28.0	1.31	1.31	1.40	1.40	1.52	1.59	1.31	1.55
29.0	1.59	1.61	1.70	1.53	1.67	1.75	1.43	1.66
30.0	1.99	2.02	2.08	1.68	1.77	1.80	1.53	1.63
31.0	1.81	1.84	1.88	1.50	1.55	1.54	1.43	1.38
32.0	1.46	1.49	1.53	1.25	1.33	1.32	1.26	1.20
33.0	1.52	1.56	1.59	1.31	1.42	1.39	1.30	1.30
34.0	1.66	1.71	1.71	1.44	1.49	1.45	1.49	1.37
35.0	1.41	1.46	1.43	1.33	1.29	1.31	1.50	1.28
36.0	1.15	1.18	1.14	1.17	1.05	1.08	1.30	1.08
37.0	1.21	1.24	1.25	1.05	1.21	1.12	1.09	1.13
38.0	1.55	1.58	1.57	1.31	1.45	1.31	1.26	1.31
39.0	1.71	1.74	1.71	1.49	1.58	1.43	1.48	1.41
40.0	1.60	1.63	1.58	1.53	1.53	1.47	1.64	1.45
41.0	1.31	1.34	1.29	1.40	1.30	1.37	1.60	1.35
42.0	1.19	1.22	1.19	1.23	1.19	1.19	1.38	1.18
43.0	1.29	1.32	1.28	1.32	1.33	1.31	1.48	1.31
43.5	1.27	1.30	1.25	1.39	1.35	1.40	1.61	1.40

Wide Band Digital Step Attenuation

ZX76-44G-30-K+

Typical Performance Data

Frequency (GHz)	Output VSWR (:1)							
	@ Attenuation Setting							
	0 dB	0.5 dB	1.0 dB	2.0 dB	4.0 dB	8.0 dB	16 dB	31.5 dB
0.1	1.31	1.18	1.07	1.64	1.20	1.04	1.07	1.07
0.2	1.31	1.19	1.08	1.65	1.21	1.04	1.06	1.07
0.3	1.32	1.20	1.09	1.65	1.21	1.04	1.07	1.07
0.4	1.34	1.21	1.10	1.67	1.22	1.04	1.06	1.07
0.5	1.34	1.21	1.11	1.67	1.22	1.05	1.07	1.07
0.6	1.34	1.21	1.11	1.67	1.22	1.05	1.07	1.07
0.7	1.34	1.22	1.11	1.67	1.23	1.05	1.07	1.07
0.8	1.34	1.22	1.11	1.67	1.23	1.06	1.07	1.08
0.9	1.34	1.22	1.11	1.67	1.23	1.06	1.08	1.08
1.0	1.34	1.22	1.11	1.66	1.23	1.06	1.08	1.08
2.0	1.32	1.20	1.10	1.65	1.22	1.03	1.05	1.06
3.0	1.31	1.20	1.10	1.65	1.25	1.03	1.03	1.03
4.0	1.29	1.19	1.10	1.62	1.25	1.06	1.07	1.06
5.0	1.27	1.17	1.07	1.58	1.21	1.04	1.06	1.06
6.0	1.25	1.15	1.06	1.56	1.21	1.03	1.04	1.04
7.0	1.27	1.20	1.13	1.57	1.26	1.12	1.13	1.12
8.0	1.28	1.26	1.22	1.50	1.28	1.23	1.24	1.24
9.0	1.22	1.22	1.22	1.39	1.24	1.27	1.29	1.29
10.0	1.17	1.18	1.20	1.32	1.19	1.28	1.30	1.30
11.0	1.09	1.12	1.17	1.25	1.15	1.29	1.32	1.33
12.0	1.06	1.09	1.19	1.19	1.08	1.32	1.34	1.35
13.0	1.21	1.18	1.25	1.30	1.10	1.28	1.28	1.29
14.0	1.25	1.18	1.21	1.42	1.15	1.19	1.17	1.18
15.0	1.23	1.15	1.12	1.47	1.18	1.08	1.06	1.07
16.0	1.18	1.10	1.05	1.44	1.18	1.04	1.05	1.05
17.0	1.08	1.04	1.05	1.36	1.15	1.10	1.11	1.12
18.0	1.07	1.07	1.08	1.34	1.16	1.12	1.13	1.14
19.0	1.10	1.13	1.13	1.34	1.22	1.20	1.22	1.23
20.0	1.17	1.24	1.30	1.20	1.25	1.37	1.39	1.40
21.0	1.40	1.45	1.55	1.09	1.29	1.50	1.48	1.49
22.0	1.46	1.51	1.61	1.12	1.27	1.48	1.44	1.45
23.0	1.42	1.47	1.56	1.08	1.25	1.44	1.40	1.41
24.0	1.65	1.70	1.81	1.25	1.44	1.67	1.62	1.63
25.0	1.98	2.02	2.16	1.54	1.71	1.97	1.90	1.90
26.0	1.76	1.78	1.93	1.58	1.69	1.95	1.91	1.90
27.0	1.39	1.38	1.51	1.51	1.51	1.71	1.72	1.71
28.0	1.33	1.30	1.39	1.57	1.49	1.65	1.67	1.66
29.0	1.48	1.43	1.44	1.83	1.64	1.70	1.74	1.73
30.0	1.75	1.67	1.57	2.10	1.76	1.62	1.65	1.64
31.0	1.60	1.55	1.43	1.90	1.59	1.35	1.36	1.36
32.0	1.27	1.26	1.17	1.49	1.26	1.07	1.08	1.08
33.0	1.22	1.19	1.10	1.47	1.22	1.13	1.15	1.14
34.0	1.39	1.36	1.25	1.64	1.36	1.19	1.19	1.20
35.0	1.35	1.36	1.27	1.50	1.30	1.13	1.13	1.14
36.0	1.24	1.27	1.25	1.23	1.13	1.13	1.12	1.11
37.0	1.11	1.11	1.04	1.30	1.06	1.19	1.21	1.20
38.0	1.41	1.37	1.26	1.63	1.30	1.26	1.28	1.28
39.0	1.63	1.59	1.46	1.83	1.47	1.30	1.28	1.30
40.0	1.54	1.53	1.42	1.71	1.46	1.26	1.23	1.25
41.0	1.33	1.35	1.28	1.44	1.32	1.16	1.15	1.16
42.0	1.20	1.21	1.14	1.34	1.18	1.03	1.03	1.03
43.0	1.30	1.30	1.21	1.49	1.29	1.13	1.12	1.14
43.5	1.33	1.35	1.26	1.49	1.36	1.19	1.18	1.20



Typical Performance Data

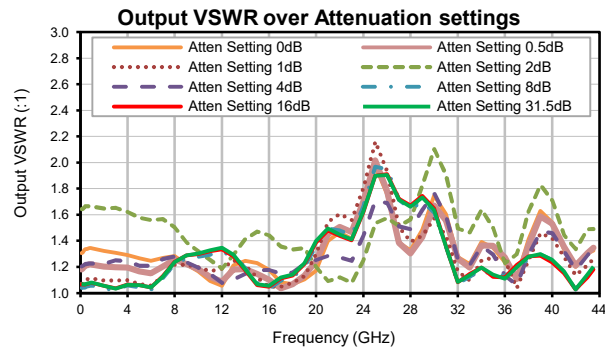
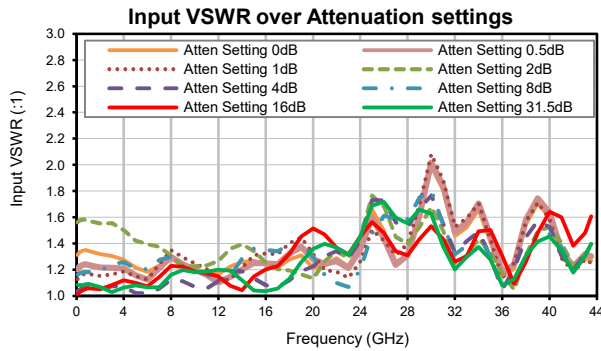
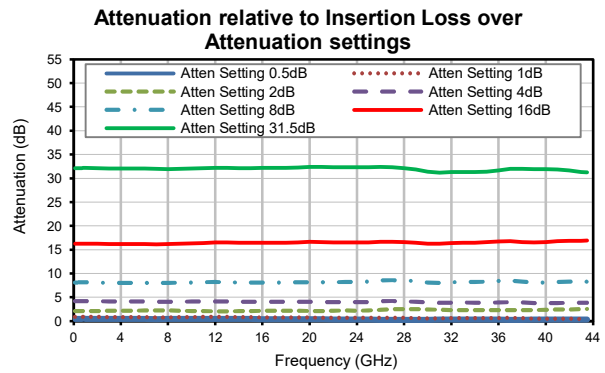
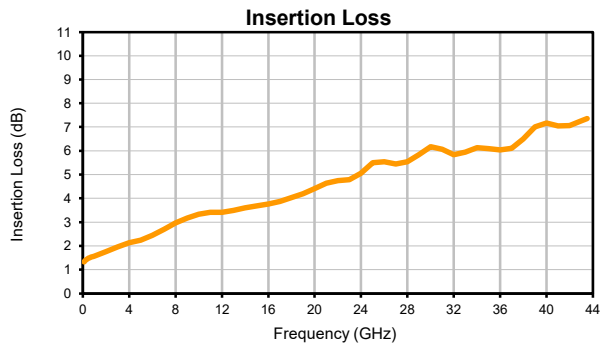

Case Style

MS

Outline Dimensions

MS3009

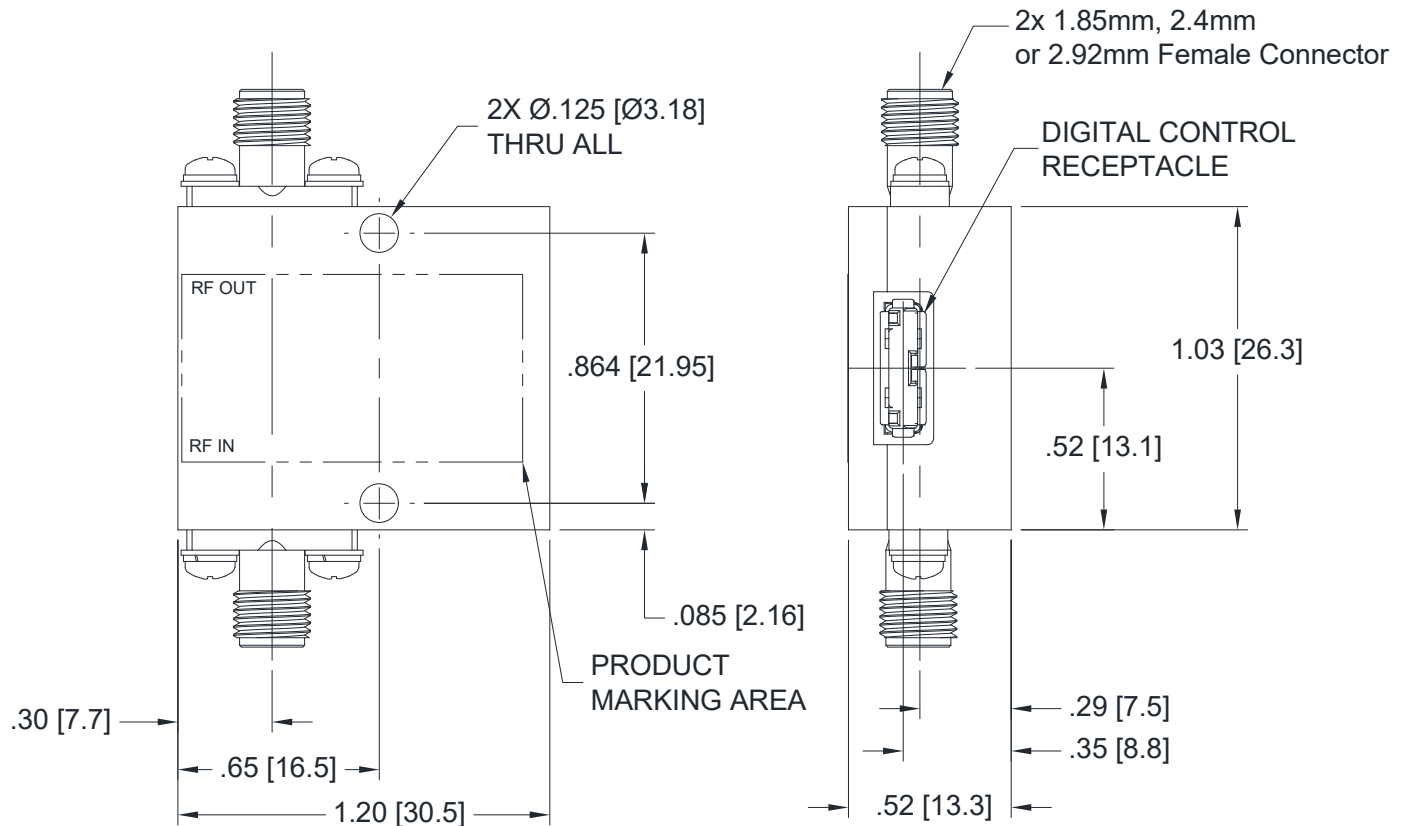

Weight: 45.36 grams

Dimensions are in inches (mm). Tolerances: 2Pl. $\pm .03$; 3Pl. $\pm .015$

Notes:

1. Case material: Brass Alloy.
2. Case finish: Gold plate.

Mini-Circuits®
ISO 9001 ISO 14001 CERTIFIED

ALL NEW
minicircuits.com

P.O. Box 350166, Brooklyn, New York 11235-0003 (718) 934-4500 Fax (718) 332-4661 For detailed performance specs & shopping online see Mini-Circuits web site



The Design Engineers Search Engine Provides ACTUAL Data Instantly From MINI-CIRCUITS At: www.minicircuits.com

RF/IF MICROWAVE COMPONENTS



All Mini-Circuits products are manufactured under exacting quality assurance and control standards, and are capable of meeting published specifications after being subjected to any or all of the following physical and environmental test.

Specification	Test/Inspection Condition	Reference/Spec
Operating Temperature	-40° to 85° C Ambient Environment	Individual Model Data Sheet
Storage Temperature	-40° to 85° C Ambient Environment	Individual Model Data Sheet
Barometric Pressure	100,000 Feet	MIL-STD-202, Method 105, Condition D
Humidity	90% RH, 65°C Units may require bake-out after humidity to restore full performance.	MIL-STD-202, Method 103
Thermal Shock	-65° to 125°C, 5 cycles	MIL-STD-202, Method 107, Condition B
Vibration (High Frequency)	20g peak, 10-2000 Hz, 12 times in each of three perpendicular directions (total 36)	MIL-STD-202, Method 204, Condition D
Mechanical Shock	100g, 6ms sawtooth, 3 shocks each direction 3 axes (total 18)	MIL-STD-202, Method 213, Condition I