

Coaxial

# Voltage Controlled Oscillator

## ZX95-1410+

Linear Tuning 850 to 1410 MHz

### Features

- low phase noise
- low pushing
- protected by US patent 6,790,049



CASE STYLE: GB956

Connectors	Model
SMA	ZX95-1410-S+

### Applications

- r & d
- lab
- instrumentation
- test equipment

**+RoHS Compliant**  
The +Suffix identifies RoHS Compliance. See our web site for RoHS Compliance methodologies and qualifications

### Electrical Specifications

MODEL NO.	FREQ. (MHz)		POWER OUTPUT (dBm)	PHASE NOISE dBc/Hz SSB at offset frequencies, kHz				TUNING				NON HARMONIC SPURIOUS (dBc)	HARMONICS (dBc)		PULLING pk-pk @12 dB (MHz)	PUSHING (MHz/V)	DC OPERATING POWER		
	Min.	Max.		Typ.	1	10	100	1000	VOLTAGE RANGE (V)	SENSITIVITY (MHz/V)	PORT CAP (pF)		3 dB MODULATION BANDWIDTH (MHz)	Typ.			Max.	Vcc (volts)	Current (mA)
ZX95-1410+	850	1410	+8	-74	-101	-123	-143	0.5	11	57-95	170	100	-90	-17	-10	10	0.5	12	30

### Maximum Ratings

Operating Temperature	-55°C to 85°C
Storage Temperature	-55°C to 100°C
Absolute Max. Supply Voltage (Vcc)	13V
Absolute Max. Tuning Voltage (Vtune)	13V
All specifications	50 ohm system

Permanent damage may occur if any of these limits are exceeded.



NOTE: When soldering the DC connections, caution must be used to avoid overheating the DC terminals. See Application Note AN-40-10.

### Outline Drawing

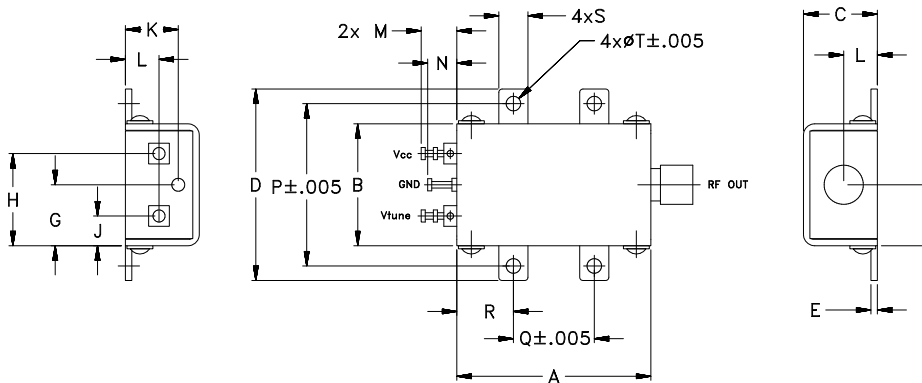

### Outline Dimensions (inch/mm)

A	B	C	D	E	F	G	H	J	K	L	M	N	P	Q	R	S	T	wt.
1.20	.75	.46	1.18	.04	.38	.38	.57	.18	.33	.21	.22	.18	1.00	.50	.35	.18	.106	grams
30.48	19.05	11.68	29.97	1.02	9.65	9.65	14.48	4.57	8.38	5.33	5.59	4.57	25.40	12.70	8.89	4.57	2.69	35.0

#### Notes

- Performance and quality attributes and conditions not expressly stated in this specification document are intended to be excluded and do not form a part of this specification document.
- Electrical specifications and performance data contained in this specification document are based on Mini-Circuit's applicable established test performance criteria and measurement instructions.
- The parts covered by this specification document are subject to Mini-Circuits standard limited warranty and terms and conditions (collectively, "Standard Terms"); Purchasers of this part are entitled to the rights and benefits contained therein. For a full statement of the Standard Terms and the exclusive rights and remedies thereunder, please visit Mini-Circuits' website at [www.minicircuits.com/MCLStore/terms.jsp](http://www.minicircuits.com/MCLStore/terms.jsp)



[www.minicircuits.com](http://www.minicircuits.com) P.O. Box 350166, Brooklyn, NY 11235-0003 (718) 934-4500 sales@minicircuits.com

REV. C  
M152326  
ED/R-7306/6  
ZX95-1410+  
RAV/URJ  
160712  
Page 1 of 2

# Performance Data & Curves\*

# ZX95-1410+

V TUNE	TUNE SENS (MHz/V)	FREQUENCY (MHz)			POWER OUTPUT (dBm)			Icc (mA)	HARMONICS (dBc)			FREQ. PUSH (MHz/V)	FREQ. PULL (MHz)	PHASE NOISE (dBc/Hz) at offsets				FREQ OFFSET (kHz)	PHASE NOISE at 1130 MHz (dBc/Hz)
		-55°C	+25°C	+85°C	-55°C	+25°C	+85°C		F2	F3	F4			1kHz	10kHz	100kHz	1MHz		
0.00	90.94	679.6	661.1	645.4	8.35	7.96	7.79	21.78	-26.6	-25.9	-35.9	0.76	6.87	-70.8	-93.1	-113.2	-133.2	1.0	-74.14
0.50	93.39	725.1	706.6	690.8	8.19	7.84	7.58	21.79	-24.6	-25.6	-37.3	0.75	9.70	-71.2	-94.4	-114.1	-134.4	2.0	-82.40
1.00	93.93	772.2	753.3	737.6	8.30	7.86	7.31	21.80	-22.7	-25.1	-39.9	0.73	13.62	-70.2	-95.7	-115.5	-135.4	3.5	-88.79
1.50	93.84	819.1	800.2	784.6	8.50	7.90	7.44	21.83	-21.0	-25.1	-45.7	0.71	12.27	-71.5	-96.3	-116.9	-137.0	6.0	-95.45
2.00	94.75	866.4	847.2	831.8	8.64	8.01	7.56	21.86	-19.6	-24.7	-49.4	0.71	12.78	-71.6	-97.8	-118.1	-137.9	8.5	-99.15
2.50	94.92	914.0	894.5	879.0	8.64	8.15	7.64	21.91	-18.5	-24.6	-47.8	0.72	8.73	-70.9	-98.5	-119.2	-139.2	10.0	-101.26
3.00	93.94	961.5	942.0	926.6	8.81	8.20	7.67	21.96	-17.4	-25.6	-44.5	0.71	5.22	-72.9	-99.7	-120.2	-140.1	20.8	-108.51
3.50	91.73	1009.3	989.0	973.6	9.03	8.26	7.82	22.01	-16.5	-27.3	-42.6	0.70	8.12	-74.4	-100.3	-121.2	-140.7	35.5	-114.27
4.00	86.35	1054.5	1034.8	1019.3	9.00	8.36	7.90	22.08	-16.0	-29.7	-39.7	0.67	9.69	-74.1	-100.2	-121.9	-141.7	60.7	-118.36
5.00	76.95	1137.4	1119.1	1104.8	9.01	8.31	7.79	22.16	-15.8	-35.8	-36.4	0.54	8.02	-75.1	-101.0	-123.5	-143.8	86.7	-122.07
5.50	73.69	1175.4	1157.6	1144.4	8.93	8.22	7.84	22.18	-16.1	-35.6	-34.3	0.46	10.36	-74.3	-100.8	-123.4	-144.2	100.0	-123.50
6.00	69.54	1210.6	1194.5	1181.8	8.71	8.07	7.72	22.20	-16.7	-35.3	-34.9	0.38	6.74	-73.3	-101.2	-124.1	-144.5	148.1	-126.99
7.00	64.68	1278.7	1263.3	1251.8	8.35	7.74	7.18	22.19	-17.3	-34.2	-35.5	0.26	3.01	-73.4	-100.9	-124.3	-145.3	211.6	-130.24
8.00	60.33	1341.4	1326.8	1316.2	8.17	7.34	7.01	22.16	-17.5	-33.0	-35.6	0.20	8.29	-73.8	-101.2	-124.8	-145.0	361.5	-135.02
8.50	58.12	1371.0	1357.0	1346.7	7.92	7.16	6.81	22.14	-17.7	-32.5	-35.3	0.19	5.64	-75.9	-102.7	-124.4	-145.5	432.2	-136.94
9.00	57.12	1399.9	1386.1	1376.1	7.63	6.96	6.52	22.12	-17.9	-32.3	-36.8	0.17	1.50	-76.2	-101.9	-124.7	-145.2	507.5	-138.10
9.50	54.41	1427.6	1414.6	1404.8	7.39	6.78	6.23	22.11	-18.3	-32.1	-36.7	0.16	6.90	-76.6	-102.0	-124.8	-145.4	600.0	-139.57
10.00	53.62	1454.7	1441.8	1432.4	7.24	6.53	5.98	22.09	-18.3	-31.1	-37.9	0.14	5.74	-75.2	-102.5	-125.0	-145.6	712.4	-140.95
10.50	52.53	1481.3	1468.6	1459.5	7.13	6.25	5.82	22.06	-18.9	-30.9	-38.9	0.13	2.08	-77.1	-103.1	-124.9	-145.3	851.6	-142.37
11.00	52.53	1507.1	1494.9	1485.8	6.90	6.00	5.69	22.04	-19.3	-30.3	-38.8	0.11	7.70	-78.4	-102.7	-124.6	-145.5	1000.0	-143.68

\*at 25°C unless mentioned otherwise

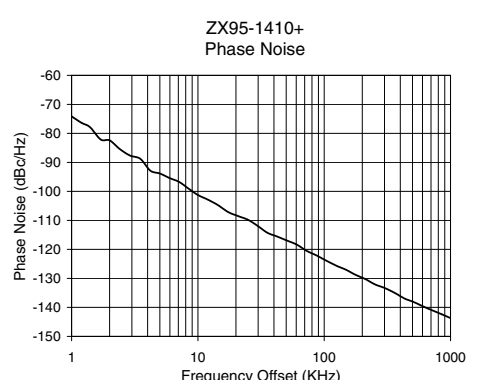
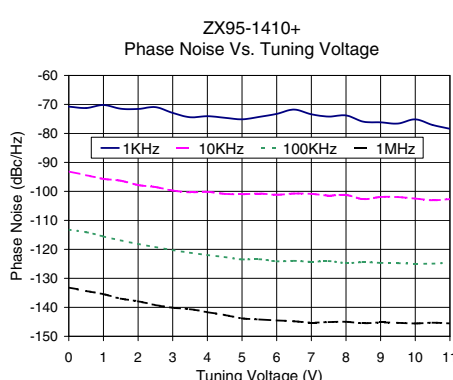
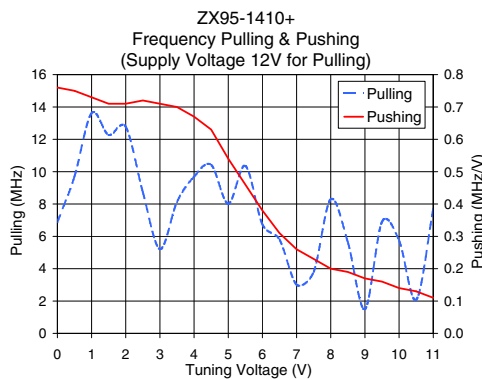
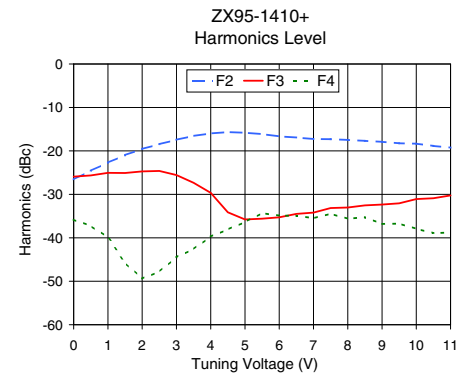
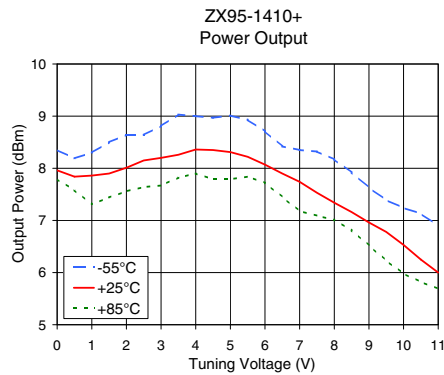
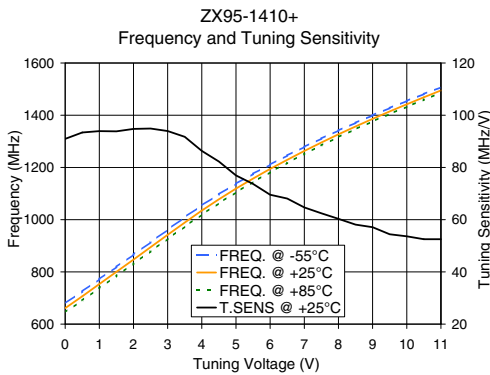

### Notes

- A. Performance and quality attributes and conditions not expressly stated in this specification document are intended to be excluded and do not form a part of this specification document.
- B. Electrical specifications and performance data contained in this specification document are based on Mini-Circuit's applicable established test performance criteria and measurement instructions.
- C. The parts covered by this specification document are subject to Mini-Circuits standard limited warranty and terms and conditions (collectively, "Standard Terms"); Purchasers of this part are entitled to the rights and benefits contained therein. For a full statement of the Standard Terms and the exclusive rights and remedies thereunder, please visit Mini-Circuits' website at [www.minicircuits.com/MCLStore/terms.jsp](http://www.minicircuits.com/MCLStore/terms.jsp)



# Voltage Controlled Oscillator

# ZX95-1410-S+

## Typical Performance Data

V TUNE	TUNE SENS (MHz/V)	FREQUENCY (MHz)			POWER OUTPUT (dBm)			HARMONICS (dBc)			FREQ. PUSH (MHz/V)	FREQ OFFSET (KHz)	PHASE NOISE (dBc/Hz)
		-55°C	+25°C	+85°C	-55°C	+25°C	+85°C	F2	F3	F4			
0.0	90.94	679.6	661.1	645.4	8.35	7.96	7.79	-26.6	-25.9	-35.9	0.76	1	-74
0.5	93.39	725.1	706.6	690.8	8.19	7.84	7.58	-24.6	-25.6	-37.3	0.75	10	-101
1.0	93.93	772.2	753.3	737.6	8.30	7.86	7.31	-22.7	-25.1	-39.9	0.73	100	-124
1.5	93.84	819.1	800.2	784.6	8.50	7.90	7.44	-21.0	-25.1	-45.7	0.71	1000	-144
2.0	94.75	866.4	847.2	831.8	8.64	8.01	7.56	-19.6	-24.7	-49.4	0.71		
2.5	94.92	914.0	894.5	879.0	8.64	8.15	7.64	-18.5	-24.6	-47.8	0.72		
3.0	93.94	961.5	942.0	926.6	8.81	8.20	7.67	-17.4	-25.6	-44.5	0.71		
3.5	91.73	1009.3	989.0	973.6	9.03	8.26	7.82	-16.5	-27.3	-42.6	0.70		
4.0	86.35	1054.5	1034.8	1019.3	9.00	8.36	7.90	-16.0	-29.7	-39.7	0.67		
4.5	82.27	1097.3	1078.0	1063.3	8.97	8.35	7.79	-15.7	-34.1	-38.1	0.63		
5.0	76.95	1137.4	1119.1	1104.8	9.01	8.31	7.79	-15.8	-35.8	-36.4	0.54		
5.5	73.69	1175.4	1157.6	1144.4	8.93	8.22	7.84	-16.1	-35.6	-34.3	0.46		
6.0	69.54	1210.6	1194.5	1181.8	8.71	8.07	7.72	-16.7	-35.3	-34.9	0.38		
6.5	68.10	1245.6	1229.2	1217.4	8.42	7.90	7.45	-16.9	-34.5	-34.9	0.31		
7.0	64.68	1278.7	1263.3	1251.8	8.35	7.74	7.18	-17.3	-34.2	-35.5	0.26		
7.5	62.45	1310.6	1295.6	1284.5	8.32	7.53	7.09	-17.3	-33.2	-34.5	0.23		
8.0	60.33	1341.4	1326.8	1316.2	8.17	7.34	7.01	-17.5	-33.0	-35.6	0.20		
8.5	58.12	1371.0	1357.0	1346.7	7.92	7.16	6.81	-17.7	-32.5	-35.3	0.19		
9.0	57.12	1399.8	1386.1	1376.1	7.63	6.96	6.52	-17.9	-32.3	-36.8	0.17		
9.5	54.41	1427.6	1414.6	1404.8	7.39	6.78	6.23	-18.3	-32.1	-36.7	0.16		
10.0	53.62	1454.7	1441.8	1432.4	7.24	6.53	5.98	-18.3	-31.1	-37.9	0.14		
10.5	52.53	1481.3	1468.6	1459.5	7.13	6.25	5.82	-18.9	-30.9	-38.9	0.13		
11.0	52.53	1507.1	1494.9	1485.8	6.90	6.00	5.69	-19.3	-30.3	-38.8	0.11		

# Voltage Controlled Oscillator

# ZX95-1410-S+

## Typical Performance Data

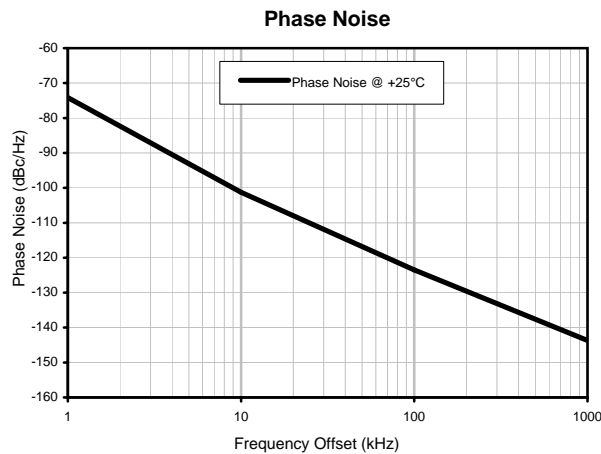
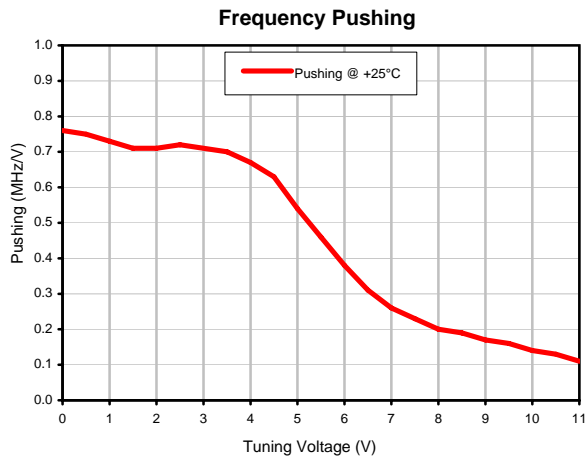
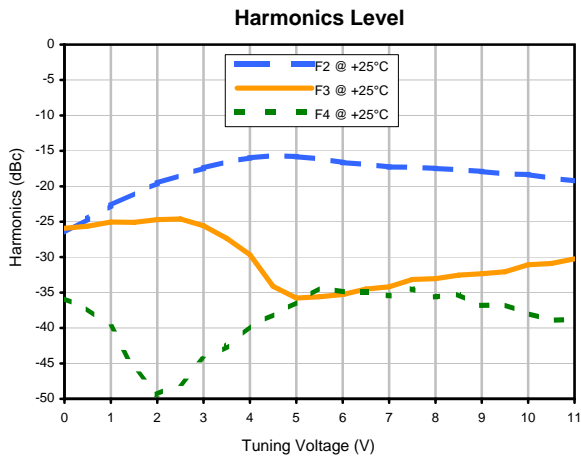
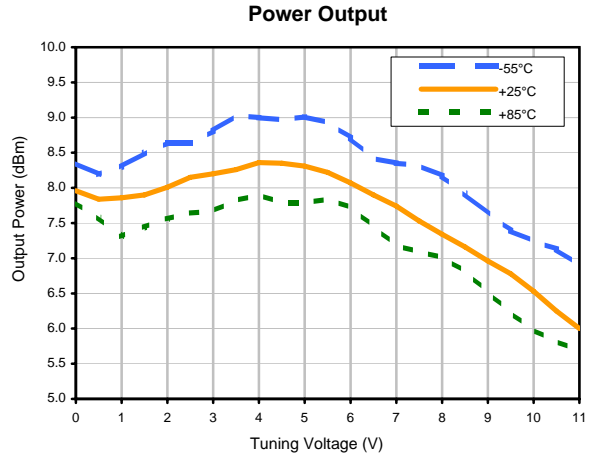
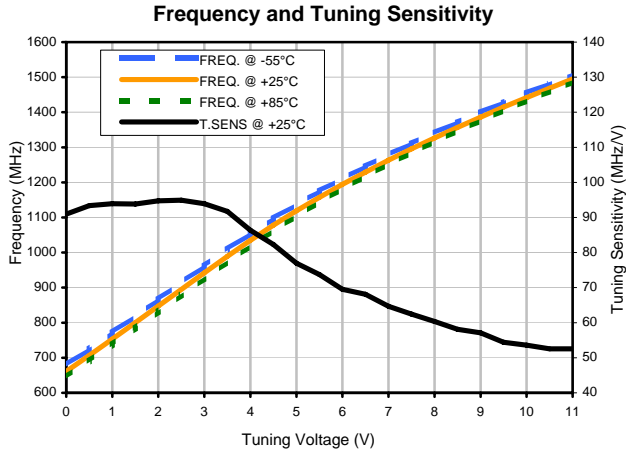

# Case Style

# GB

## Outline Dimensions

## GB956

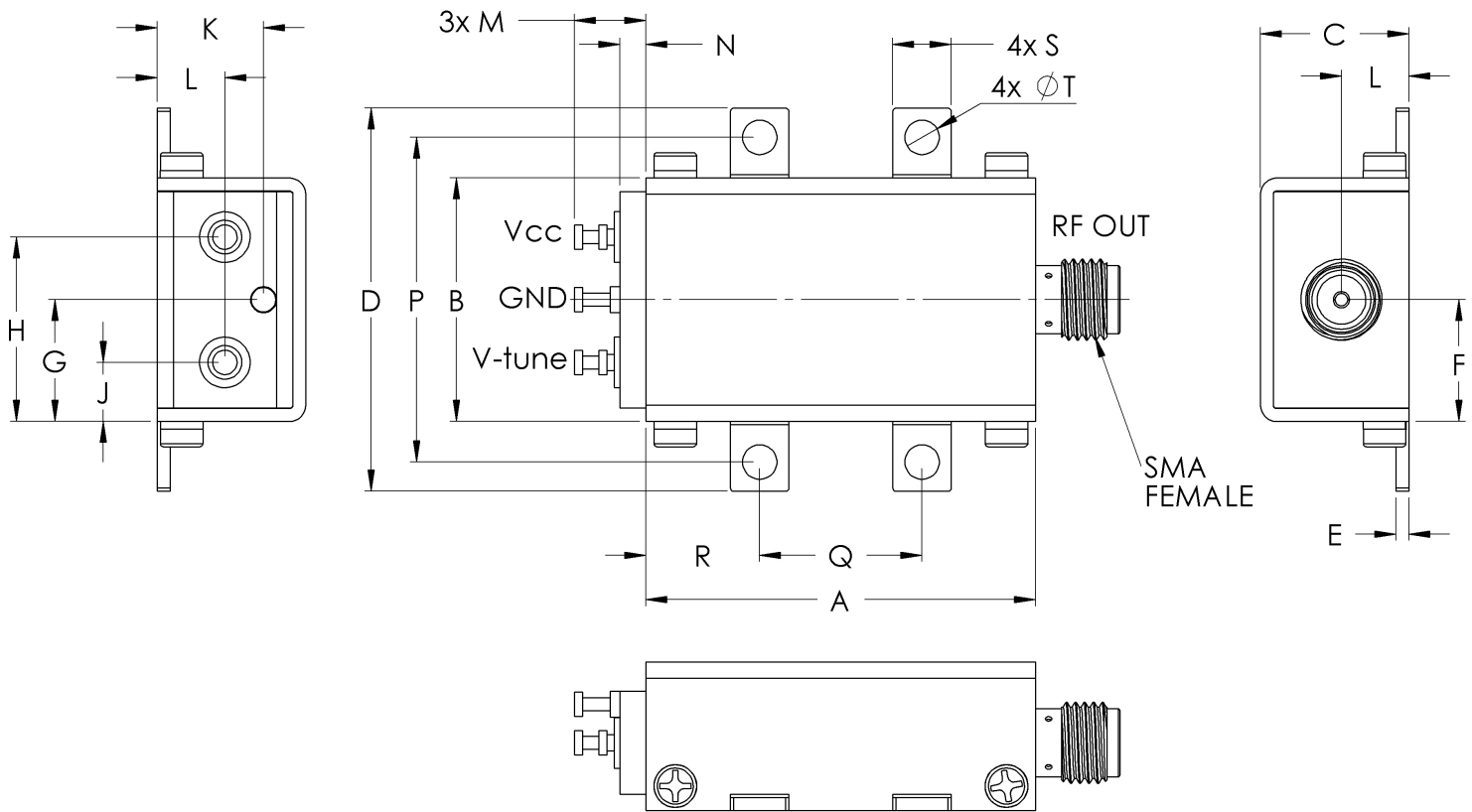

CASE #.	A	B	C	D	E	F	G	H	J	K	L	M	N
GB956	1.20 (30.48)	.75 (19.15)	.46 (11.61)	1.18 (30.07)	.04 (1.02)	.38 (9.53)	.38 (9.53)	.57 (14.43)	.18 (4.62)	.33 (8.31)	.21 (5.28)	.22 (5.59)	.08 (2.03)

CASE #.	P	Q	R	S	T	WT GRAMS
GB956	1.00 (25.4)	.50 (12.7)	.35 (8.89)	.18 (4.57)	.106 (2.69)	35

Dimensions are in inches (mm). Tolerances: 2Pl.  $\pm .03$ ; 3Pl.  $\pm .015$   
Tolerance on hole size and interaxes dimensions to be  $\pm .005$ .

### Note:

1. Case material: Brass
2. Case finish: Nickel plate

**Mini-Circuits®**

INTERNET <http://www.minicircuits.com>

P.O. Box 350166, Brooklyn, New York 11235-0003 (718) 934-4500 Fax (718) 332-4661

Distribution Centers NORTH AMERICA 800-654-7949 • 417-335-5935 • Fax 417-335-5945 • EUROPE 44-1252-832600 • Fax 44-1252-837010

Mini-Circuits ISO 9001 & ISO 14001 Certified



All Mini-Circuits products are manufactured under exacting quality assurance and control standards, and are capable of meeting published specifications after being subjected to any or all of the following physical and environmental test.

Specification	Test/Inspection Condition	Reference/Spec
Operating Temperature	-55° to 85°C Ambient Environment	Individual Model Data Sheet
Storage Temperature	-55° to 100° C Ambient Environment	Individual Model Data Sheet
Barometric Pressure	100,000 Feet	MIL-STD-202, Method 105, Condition D
Humidity	90% RH, 65°C Units may require bake-out after humidity to restore full performance.	MIL-STD-202, Method 103
Thermal Shock	-65° to 125°C, 5 cycles	MIL-STD-202, Method 107, Condition B
Vibration (High Frequency)	20g peak, 10-2000 Hz, 12 times in each of three perpendicular directions (total 36)	MIL-STD-202, Method 204, Condition D
Mechanical Shock	100g, 6ms sawtooth, 3 shocks each direction 3 axes (total 18)	MIL-STD-202, Method 213, Condition I