

# Coaxial Reflectionless Low Pass Filter

## ZXLF Series

50Ω

DC to 11 GHz



## The Big Deal

- Patented design terminates Stopband signals
- Stopband up to 35 GHz
- High Stopband rejection, up to 50 dB

## Product Overview

Mini-Circuits' ZXLF Series reflectionless filters employ a novel filter topology which absorbs and terminates stop band signals internally rather than reflecting them back to the source. Reflectionless filters eliminate stopband reflections, allowing them to be paired with sensitive devices and used in applications that otherwise require circuits such as isolation amplifiers or attenuators. This is developed in a new broadband, stable connectorized package.

## Key Features

Feature	Advantages
Easy integration with sensitive reflective components, e.g. mixers, multipliers	Reflectionless filters absorb unwanted signals, preventing reflections back to the source. This reduces generation of additional unwanted signals without the need for extra components like attenuators, improving system dynamic range.
Cascadable	Reflectionless filters can be cascaded in multiple sections to provide sharper and higher attenuation, while also preventing any standing waves that could affect pass band signals.
Excellent stability over temperature	Minimal variation in electrical performance across temperature.
Operating temperature up to 105°C	Suitable for operation close to high power components.
Broadband connectorized package	The connectorized package works well even in high frequencies and easy to interface with other devices. This is well suited for test setups.

### Notes

- A. Performance and quality attributes and conditions not expressly stated in this specification document are intended to be excluded and do not form a part of this specification document.  
B. Electrical specifications and performance data contained in this specification document are based on Mini-Circuit's applicable established test performance criteria and measurement instructions.  
C. The parts covered by this specification document are subject to Mini-Circuits standard limited warranty and terms and conditions (collectively, "Standard Terms"); Purchasers of this part are entitled to the rights and benefits contained therein. For a full statement of the Standard Terms and the exclusive rights and remedies thereunder, please visit Mini-Circuits' website at [www.minicircuits.com/MCLStore/terms.jsp](http://www.minicircuits.com/MCLStore/terms.jsp)



# Low Pass Filter

## ZXLF-K252H+

50Ω DC to 2500 MHz



Generic photo used for illustration purposes only

CASE STYLE: UK3042  
Connectors Model  
2.92mm-F ZXLF-K252H+

### Features

- Match to 50Ω in the stop band, eliminates undesired reflections
- Cascadable
- Temperature stable, up to 105°C
- Protected by US Patents 8,392,495; 9,705,467, additional patent pending
- Protected by China Patent 201080014266.1
- Protected by Taiwan Patent I581494

### Applications

- Telecom
- Aerospace & Defense
- 24-25MHz ISM band
- GPS
- 4G

### Electrical Specifications at 25°C

Parameter		F#	Frequency (MHz)	Min.	Typ.	Max.	Unit
Pass Band	Insertion Loss	DC-F1	DC- 2500	-	2.2	3.2	dB
		F2	3900	-	3.5	-	dB
	VSWR	DC-F1	DC- 2500	-	1.3	-	:1
Stop Band	Rejection	F3-F4	7000 - 14500	27	36	-	dB
		F4-F5	14500 - 17000	-	50	-	dB
	VSWR	F3-F4	7000 - 14500	-	1.5	-	:1
		F4-F5	14500 - 17000	-	2.2	-	:1

### Absolute Maximum Ratings<sup>3</sup>

Parameter	Ratings
Operating Temperature	-55°C to +105°C
Storage Temperature	-55°C to +105°C
RF Power Input, Passband (DC-F1) <sup>1</sup>	7.9W at 25°C
RF Power Input, Stopband (F2-F5) <sup>2</sup>	1.58W at 25°C

<sup>1</sup> Passband rating derates linearly to 3.9W at 105°C ambient

<sup>2</sup> Stopband rating derates linearly to 0.75W at 105°C ambient

<sup>3</sup> Permanent damage may occur if any of these limits are exceeded

### ESD rating

Human body model (HBM): Class 1A(Pass 250V) in accordance with ANSI/ESD 5.1-2001

### Functional Schematic

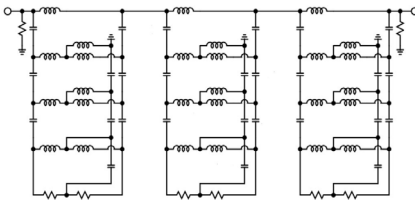

### Typical Frequency Response

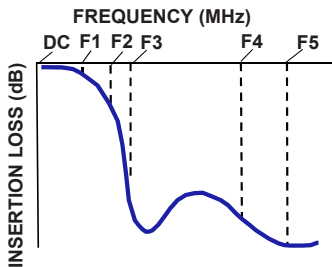

### Typical Performance Data at 25°C

Frequency (MHz)	Insertion Loss (dB)	VSWR (:1)
1	0.85	1.11
10	0.82	1.10
100	0.89	1.10
200	0.96	1.12
500	1.12	1.18
1000	1.38	1.29
2000	1.96	1.40
2500	2.18	1.32
3000	2.46	1.16
3900	3.51	1.26
5200	11.48	1.24
5500	20.31	1.23
5700	34.04	1.23
7000	37.58	1.61
10000	33.45	1.48
12000	48.72	1.24
13000	54.17	1.26
14500	55.51	1.63
17000	54.57	2.21
20000	46.55	2.34

**+RoHS Compliant**  
The +Suffix identifies RoHS Compliance. See our web site for RoHS Compliance methodologies and qualifications

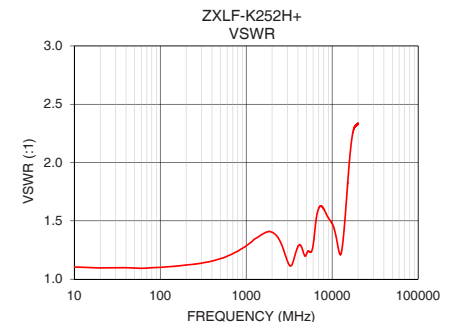
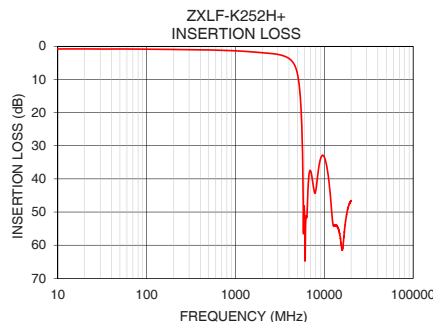

**Notes**

- A. Performance and quality attributes and conditions not expressly stated in this specification document are intended to be excluded and do not form a part of this specification document.
- B. Electrical specifications and performance data contained in this specification document are based on Mini-Circuit's applicable established test performance criteria and measurement instructions.
- C. The parts covered by this specification document are subject to Mini-Circuits standard limited warranty and terms and conditions (collectively, "Standard Terms"); Purchasers of this part are entitled to the rights and benefits contained therein. For a full statement of the Standard Terms and the exclusive rights and remedies thereunder, please visit Mini-Circuits' website at [www.minicircuits.com/MCLStore/terms.jsp](http://www.minicircuits.com/MCLStore/terms.jsp)



## Coaxial Connections

PORT - 1	2.92mm-Female
PORT - 2	2.92mm-Female

## Outline Drawing



## Outline Dimensions (inch/mm)

A	B	C	D	E	F
<b>.68</b>	<b>.60</b>	<b>.39</b>	<b>.200</b>	<b>.10</b>	<b>.400</b>
17.1	15.2	10.0	5.08	2.5	10.16
G	H	J	K	Wt.	
<b>.24</b>	<b>.070</b>	<b>.22</b>	<b>.30</b>	grams	
6.0	1.78	5.5	7.6	<b>24</b>	

Note: Please refer to case style drawing for details

### Notes

- A. Performance and quality attributes and conditions not expressly stated in this specification document are intended to be excluded and do not form a part of this specification document.
- B. Electrical specifications and performance data contained in this specification document are based on Mini-Circuit's applicable established test performance criteria and measurement instructions.
- C. The parts covered by this specification document are subject to Mini-Circuits standard limited warranty and terms and conditions (collectively, "Standard Terms"); Purchasers of this part are entitled to the rights and benefits contained therein. For a full statement of the Standard Terms and the exclusive rights and remedies thereunder, please visit Mini-Circuits' website at [www.minicircuits.com/MCLStore/terms.jsp](http://www.minicircuits.com/MCLStore/terms.jsp)

# Coaxial Reflectionless Low Pass Filter

# ZXLF-K252H+

## Typical Performance Data

FREQ.	Insertion Loss	Input Return Loss	Output Return Loss	FREQ.	Group Delay
(MHz)	(dB)	(dB)	(dB)	(MHz)	(ns)
1	0.85	26.11	25.90	1	0.29
5	0.83	25.90	25.80	2	0.29
10	0.82	26.14	26.11	3	0.29
15	0.81	26.51	26.47	4	0.29
40	0.85	26.50	26.60	5	0.29
60	0.82	27.08	27.03	6	0.29
100	0.89	26.30	26.35	7	0.29
500	1.12	21.98	21.84	8	0.29
560	1.15	21.54	21.35	9	0.29
600	1.17	21.13	20.94	10	0.29
680	1.21	20.50	20.30	60	0.29
700	1.22	20.35	20.13	100	0.29
800	1.27	19.52	19.40	140	0.29
900	1.32	18.81	18.68	180	0.29
1000	1.38	18.19	18.05	220	0.29
1100	1.44	17.59	17.49	260	0.29
1200	1.49	17.04	16.95	300	0.29
1300	1.55	16.56	16.52	340	0.29
1400	1.62	16.25	16.23	380	0.29
1500	1.68	15.94	15.94	420	0.29
2000	1.96	15.37	15.52	460	0.29
2500	2.18	16.86	17.21	500	0.29
3000	2.46	21.20	22.60	540	0.29
3900	3.51	18.36	18.77	580	0.29
4000	3.70	17.91	18.18	620	0.29
4500	5.12	18.43	18.84	660	0.29
4600	5.56	19.02	19.50	700	0.29
4700	6.09	19.53	20.23	740	0.29
4800	6.74	20.05	20.89	780	0.29
4900	7.56	20.12	20.87	820	0.29
5000	8.56	20.02	20.43	860	0.29
5100	9.83	19.72	19.86	900	0.29
5200	11.48	19.56	19.49	940	0.29
5300	13.59	19.67	19.35	980	0.29
5500	20.31	20.15	19.66	1020	0.29
6000	51.68	18.57	18.05	1060	0.29
6500	45.05	15.09	13.87	1100	0.29
7000	37.58	14.38	12.64	1140	0.29
7500	42.04	14.03	12.47	1180	0.29
8000	43.70	13.49	12.72	1220	0.29
8500	38.06	13.12	13.17	1260	0.29
9000	34.21	12.91	13.60	1300	0.29
9500	32.91	12.74	13.95	1340	0.29
10000	33.45	12.64	14.30	1380	0.29
10500	35.39	12.78	14.90	1420	0.29
11000	38.55	13.33	15.95	1460	0.29
11500	43.02	14.29	17.51	1500	0.29
12000	48.72	15.37	19.46	1540	0.29
12500	53.53	15.75	20.37	1580	0.29
13000	54.17	14.72	18.91	1620	0.29
13500	54.07	12.92	16.38	1660	0.29
14000	54.43	11.21	14.17	1700	0.29
14500	55.51	9.84	12.42	1740	0.29
15000	57.21	8.82	11.08	1780	0.29
15500	60.06	8.13	10.08	1820	0.29
16000	61.17	7.72	9.34	1860	0.29
16500	58.26	7.60	8.82	1900	0.29
16800	56.14	7.63	8.58	2000	0.29
17000	54.57	7.74	8.46	2100	0.30
20000	46.55	11.10	7.93	2500	0.31



ISO 9001 ISO 14001 AS 9100 CERTIFIED



P.O. Box 350166, Brooklyn, New York 11235-0003 (718) 934-4500 • Fax (718) 332-4661 For detailed performance specs & shopping online see Mini-Circuits web site

The Design Engineers Search Engine Provides ACTUAL Data Instantly From MINI-CIRCUITS At: [www.minicircuits.com](http://www.minicircuits.com)

IF/RF MICROWAVE COMPONENTS

REV. OR  
ZXLF-K252H+  
210122

Page 1 of 1

Typical Performance Curves

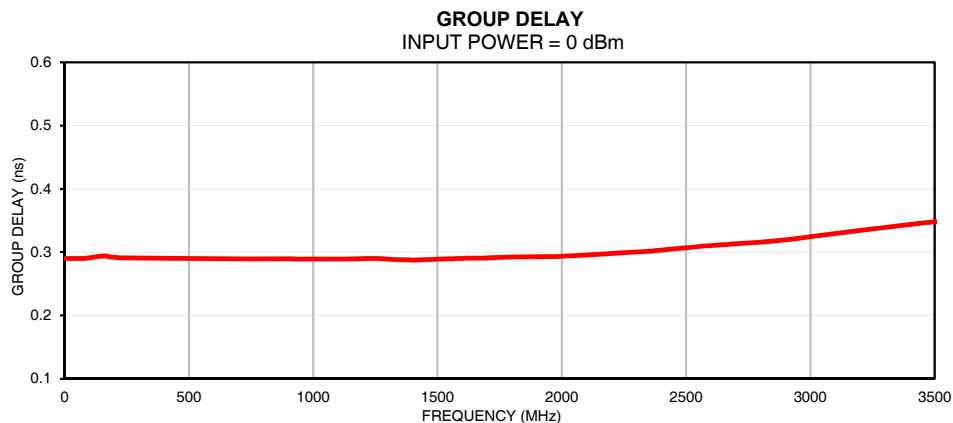
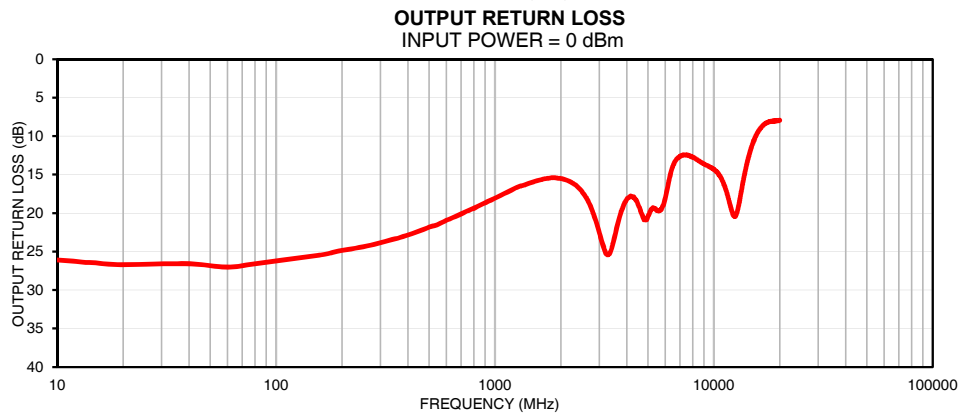
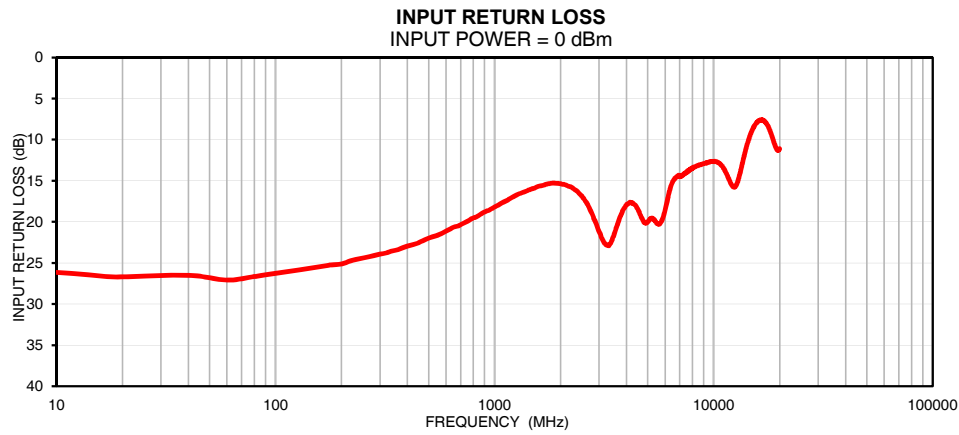
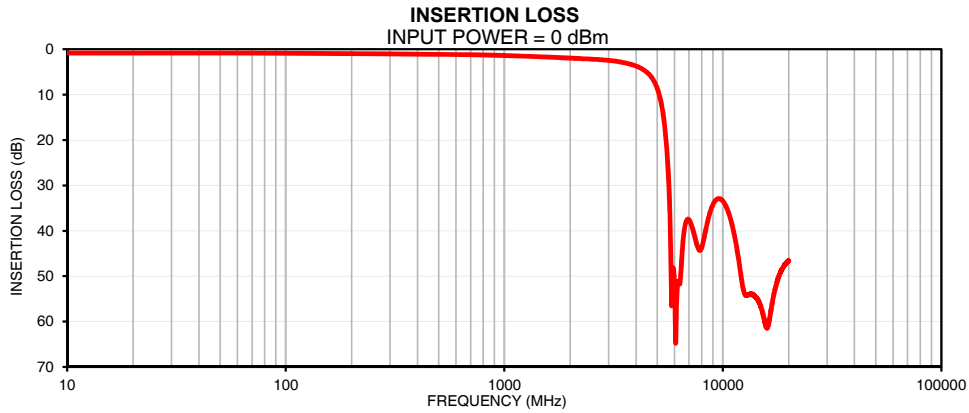

## Outline Dimensions

UK3042

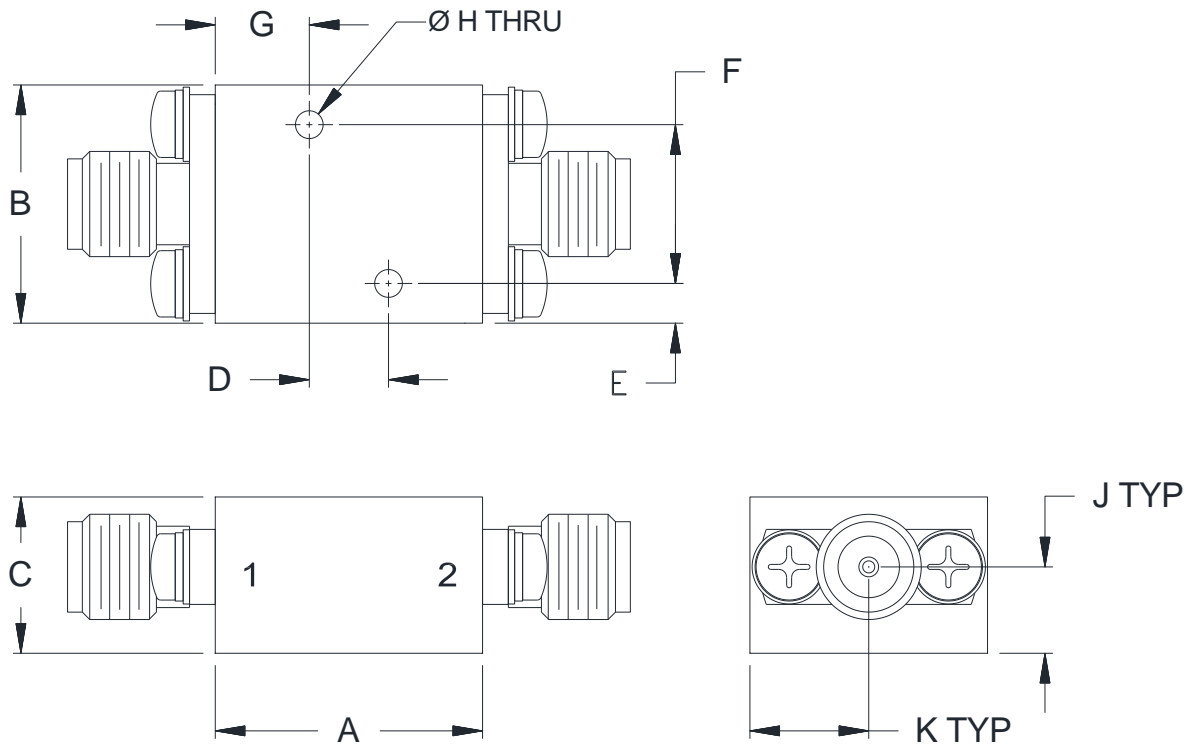

CASE#	A	B	C	D	E	F
UK3042	.68 (17.1)	.60 (15.2)	.39 (10.0)	.200 (5.08)	.10 (2.5)	.400 (10.16)

CASE#	G	H	J	K	WT.GRAMS
UK3042	.24 (6.0)	.070 (1.78)	.22 (5.5)	.30 (7.6)	24

Dimensions are in inches (mm). Tolerances: 2 Pl.  $\pm .050$ ; 3 Pl.  $\pm .015$

### Notes:

1. Case material: Brass alloy.
2. Case Finish:
  - a. Case & Cover of the units –Gold plating.
3. Refer to the individual model data sheet for the type of connectors available.



P.O. Box 350166, Brooklyn, New York 11235-0003 (718) 934-4500 Fax (718) 332-4661 For detailed performance specs & shopping online see Mini-Circuits web site



The Design Engineers Search Engine Provides ACTUAL Data Instantly From MINI-CIRCUITS At: [www.minicircuits.com](http://www.minicircuits.com)

RF/IF MICROWAVE COMPONENTS

All Mini-Circuits products are manufactured under exacting quality assurance and control standards, and are capable of meeting published specifications after being subjected to any or all of the following physical and environmental test.

<b>Specification</b>	<b>Test/Inspection Condition</b>	<b>Reference/Spec</b>
Operating Temperature	-55° to 105°C Ambient Environment	Individual Model Data Sheet
Storage Temperature	-55° to 105°C Ambient Environment	Individual Model Data Sheet