

Coaxial Reflectionless Low Pass Filter

ZXLF Series

50Ω DC to 11 GHz



The Big Deal

- Patented design terminates Stopband signals
- Stopband up to 35 GHz
- High Stopband rejection, up to 50 dB

Product Overview

Mini-Circuits' ZXLF Series reflectionless filters employ a novel filter topology which absorbs and terminates stop band signals internally rather than reflecting them back to the source. Reflectionless filters eliminate stopband reflections, allowing them to be paired with sensitive devices and used in applications that otherwise require circuits such as isolation amplifiers or attenuators. This is developed in a new broadband, stable connectorized package.

Key Features

Feature	Advantages
Easy integration with sensitive reflective components, e.g. mixers, multipliers	Reflectionless filters absorb unwanted signals, preventing reflections back to the source. This reduces generation of additional unwanted signals without the need for extra components like attenuators, improving system dynamic range.
Cascadable	Reflectionless filters can be cascaded in multiple sections to provide sharper and higher attenuation, while also preventing any standing waves that could affect pass band signals.
Excellent stability over temperature	Minimal variation in electrical performance across temperature.
Operating temperature up to 105°C	Suitable for operation close to high power components.
Broadband connectorized package	The connectorized package works well even in high frequencies and easy to interface with other devices. This is well suited for test setups.

Notes

- A. Performance and quality attributes and conditions not expressly stated in this specification document are intended to be excluded and do not form a part of this specification document.
B. Electrical specifications and performance data contained in this specification document are based on Mini-Circuit's applicable established test performance criteria and measurement instructions.
C. The parts covered by this specification document are subject to Mini-Circuits standard limited warranty and terms and conditions (collectively, "Standard Terms"); Purchasers of this part are entitled to the rights and benefits contained therein. For a full statement of the Standard Terms and the exclusive rights and remedies thereunder, please visit Mini-Circuits' website at www.minicircuits.com/MCLStore/terms.jsp



Low Pass Filter

ZXLF-K73+

50Ω DC to 7000 MHz



Generic photo used for illustration purposes only

CASE STYLE: UK3042
Connectors Model
2.92mm-F ZXLF-K73+

Features

- Match to 50Ω in the stop band, eliminates undesired reflections
- Cascadable
- Temperature stable, up to 105°C
- Protected by US Patent No. 8,392,495

Applications

- Telecomm
- 5G & Extended Wi-Fi

Electrical Specifications at 25°C

Parameter		F#	Frequency (MHz)	Min.	Typ.	Max.	Unit
Pass Band	Insertion Loss	DC-F1	DC- 7000	-	1.6	2.5	dB
		F2	9400	-	3.0	-	dB
	VSWR	DC-F1	DC- 7000	-	1.3	-	:1
Stop Band	Rejection	F3-F5	11700 - 21300	11	15	-	dB
		F3-F4	11700 - 18500	-	1.5	-	:1
	VSWR	F4-F5	18500 - 21300	-	2.2	-	:1

Absolute Maximum Ratings³

Parameter	Ratings
Operating Temperature	-55°C to +105°C
Storage Temperature	-55°C to +105°C
RF Power Input, Passband (DC-F1) ¹	2W at 25°C
RF Power Input, Stopband (F2-F5) ²	100mW at 25°C

¹ Passband rating derates linearly to 1W at 105°C ambient

² Stopband rating derates linearly to 50mW at 105°C ambient

³ Permanent damage may occur if any of these limits are exceeded

Functional Schematic

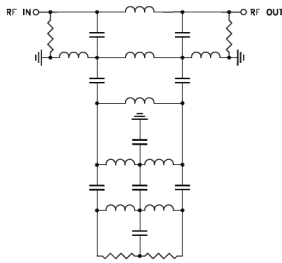

Typical Frequency Response

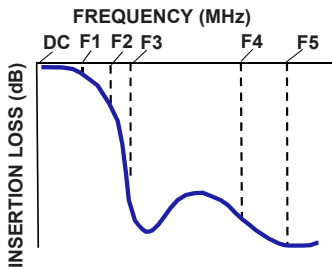

Typical Performance Data at 25°C

Frequency (MHz)	Insertion Loss (dB)	VSWR (:1)
1	0.36	1.03
10	0.29	1.02
100	0.34	1.02
250	0.44	1.02
300	0.46	1.02
500	0.53	1.06
1000	0.67	1.14
2500	1.04	1.38
3000	1.12	1.43
5000	1.28	1.41
6000	1.39	1.33
7000	1.58	1.30
8100	2.01	1.43
9400	3.01	1.55
10000	3.94	1.46
11700	15.70	1.08
12000	20.17	1.29
18500	26.54	1.26
20000	18.63	1.78
21300	16.03	2.50

+RoHS Compliant

The +Suffix identifies RoHS Compliance. See our web site for RoHS Compliance methodologies and qualifications

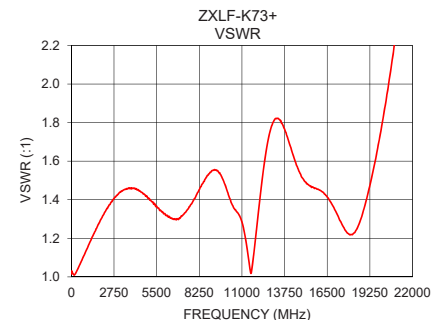
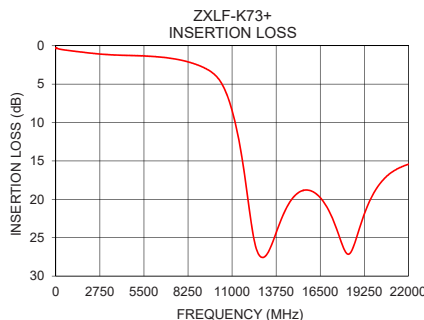

Notes

- Performance and quality attributes and conditions not expressly stated in this specification document are intended to be excluded and do not form a part of this specification document.
- Electrical specifications and performance data contained in this specification document are based on Mini-Circuits' applicable established test performance criteria and measurement instructions.
- The parts covered by this specification document are subject to Mini-Circuits standard limited warranty and terms and conditions (collectively, "Standard Terms"); Purchasers of this part are entitled to the rights and benefits contained therein. For a full statement of the Standard Terms and the exclusive rights and remedies thereunder, please visit Mini-Circuits' website at www.minicircuits.com/MCLStore/terms.jsp



Coaxial Connections

PORT - 1	2.92mm-Female
PORT - 2	2.92mm-Female

Outline Drawing

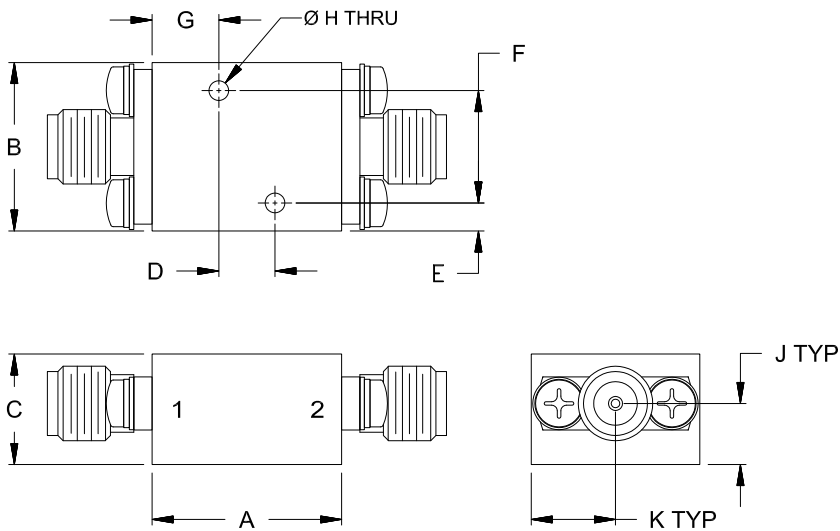

Outline Dimensions (inch/mm)

A	B	C	D	E	F
.68	.60	.39	.200	.10	.400
17.1	15.2	10.0	5.08	2.5	10.16
G	H	J	K	Wt.	
.24	.070	.22	.30	grams	
6.0	1.78	5.5	7.6	24	

Note: Please refer to case style drawing for details

Notes

- A. Performance and quality attributes and conditions not expressly stated in this specification document are intended to be excluded and do not form a part of this specification document.
- B. Electrical specifications and performance data contained in this specification document are based on Mini-Circuit's applicable established test performance criteria and measurement instructions.
- C. The parts covered by this specification document are subject to Mini-Circuits standard limited warranty and terms and conditions (collectively, "Standard Terms"); Purchasers of this part are entitled to the rights and benefits contained therein. For a full statement of the Standard Terms and the exclusive rights and remedies thereunder, please visit Mini-Circuits' website at www.minicircuits.com/MCLStore/terms.jsp

Coaxial Reflectionless Low Pass Filter

ZXLF-K73+

Typical Performance Data

FREQ.	Insertion Loss	Input Return Loss	Output Return Loss
(MHz)	(dB)	(dB)	(dB)
1	0.36	37.34	37.31
5	0.29	38.35	38.77
10	0.29	38.79	38.96
15	0.30	39.26	39.20
25	0.31	39.70	39.56
50	0.26	37.23	37.23
100	0.34	41.01	40.55
250	0.44	42.51	42.08
300	0.46	39.28	38.70
450	0.52	32.86	32.74
500	0.53	31.36	31.17
550	0.54	30.16	30.05
600	0.57	29.07	29.01
650	0.57	28.09	28.03
750	0.61	26.46	26.39
900	0.64	24.58	24.38
950	0.65	23.93	23.85
1000	0.67	23.46	23.35
1500	0.80	19.66	19.52
2000	0.92	17.40	17.22
2500	1.04	16.01	15.78
3000	1.12	15.08	14.84
3500	1.19	14.66	14.38
4000	1.23	14.58	14.34
5000	1.28	15.42	15.36
6000	1.39	17.01	16.83
6850	1.54	17.71	17.25
7000	1.58	17.61	17.17
7250	1.66	17.09	16.79
7500	1.75	16.55	16.41
7800	1.87	15.84	15.89
8100	2.01	15.05	15.33
8500	2.25	14.16	14.65
9000	2.62	13.41	14.03
9400	3.01	13.31	14.08
9900	3.73	14.25	15.37
10000	3.94	14.60	15.80
10500	5.51	16.45	18.22
11000	8.44	18.06	18.61
11700	15.70	28.70	44.33
12000	20.17	17.96	20.61
12500	26.38	12.51	13.29
12750	27.43	11.43	11.72
13200	27.07	10.72	10.35
13500	25.75	10.80	10.09
14000	22.98	11.66	10.36
14200	21.96	12.15	10.67
14500	20.71	12.92	11.29
15000	19.36	13.97	12.68
15200	19.05	14.21	13.36
15500	18.81	14.51	14.45
16000	18.96	14.72	16.51
16250	19.29	14.92	17.60
17000	21.32	16.61	20.10
17250	22.41	17.55	20.15
17500	23.73	18.64	19.77
18500	26.54	18.64	16.02
20000	18.63	11.07	10.35
21000	16.41	8.07	7.53
21300	16.03	7.38	6.94

FREQ.	Group Delay
(MHz)	(ns)
1	0.42
5	0.21
10	0.18
15	0.21
20	0.22
25	0.22
30	0.20
35	0.23
40	0.21
45	0.26
50	0.20
100	0.20
200	0.20
300	0.19
400	0.19
500	0.19
750	0.19
1000	0.19
1050	0.19
1100	0.19
1200	0.19
1250	0.19
1300	0.19
1500	0.19
1600	0.19
1750	0.19
1800	0.19
2000	0.19
2100	0.19
2200	0.19
2300	0.19
2400	0.19
2500	0.19
2600	0.19
2700	0.19
2800	0.19
2900	0.19
3000	0.19
3100	0.19
3200	0.19
3300	0.19
3400	0.19
3500	0.19
3600	0.19
3700	0.19
3800	0.19
3900	0.19
4000	0.19
4100	0.19
4200	0.19
4300	0.19
4400	0.19
4500	0.19
4750	0.19
5000	0.20
5500	0.20
6000	0.20
6250	0.20
6500	0.20
7000	0.21



P.O. Box 350166, Brooklyn, New York 11235-0003 (718) 934-4500 • Fax (718) 332-4661 For detailed performance specs & shopping online see Mini-Circuits web site

The Design Engineers Search Engine Provides ACTUAL Data Instantly From MINI-CIRCUITS At: www.minicircuits.com

IF/RF MICROWAVE COMPONENTS

REV. OR
ZXLF-K73+
201117

Page 1 of 1

Typical Performance Curves

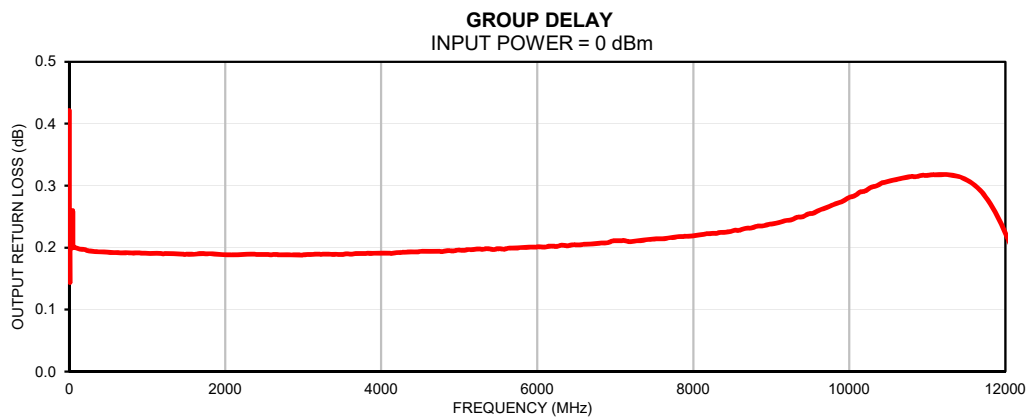
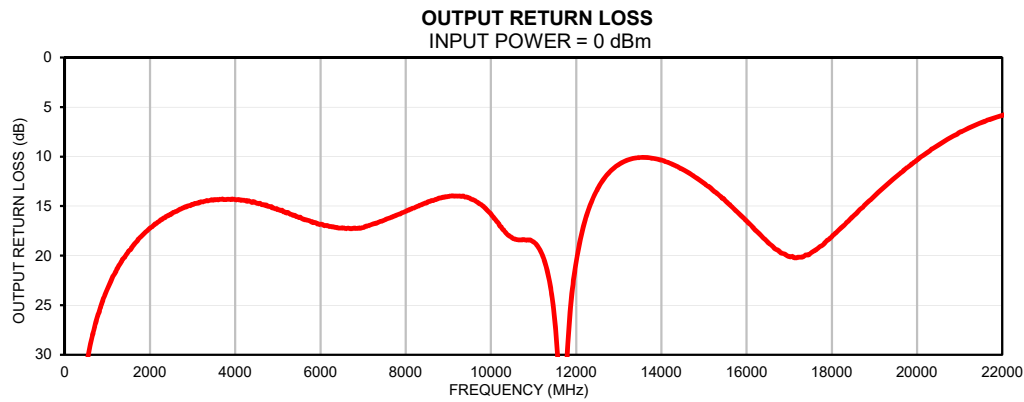
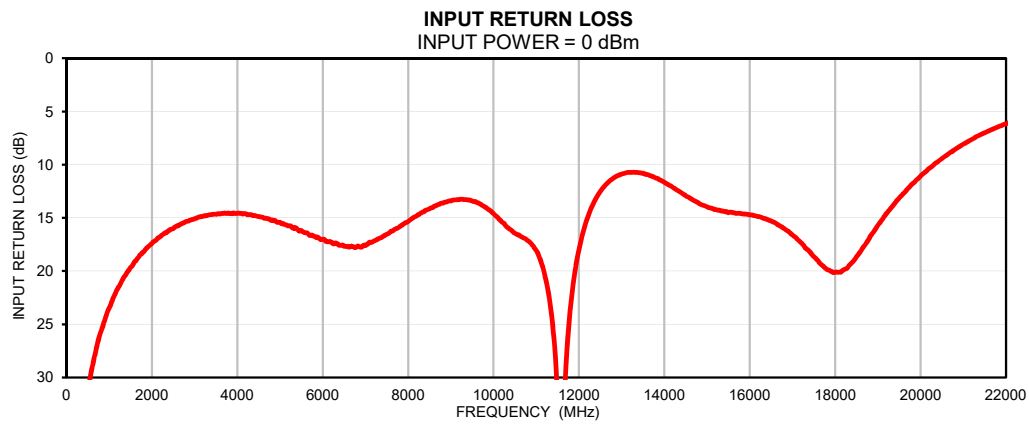
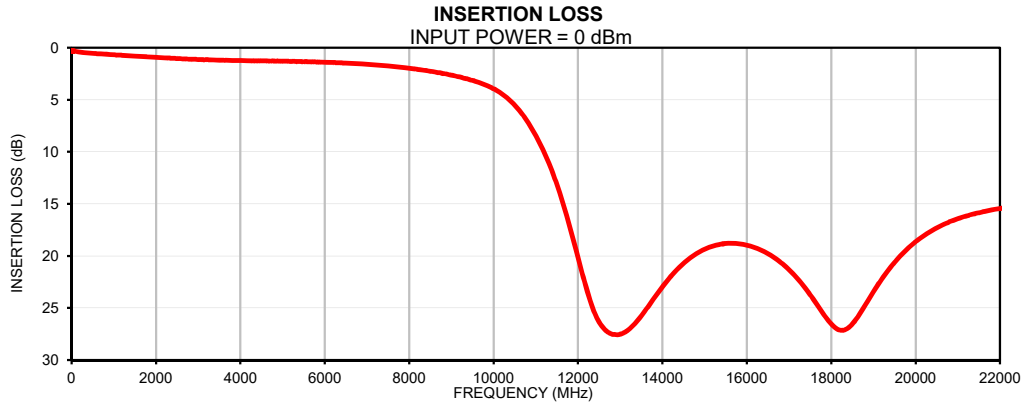

Outline Dimensions

UK3042

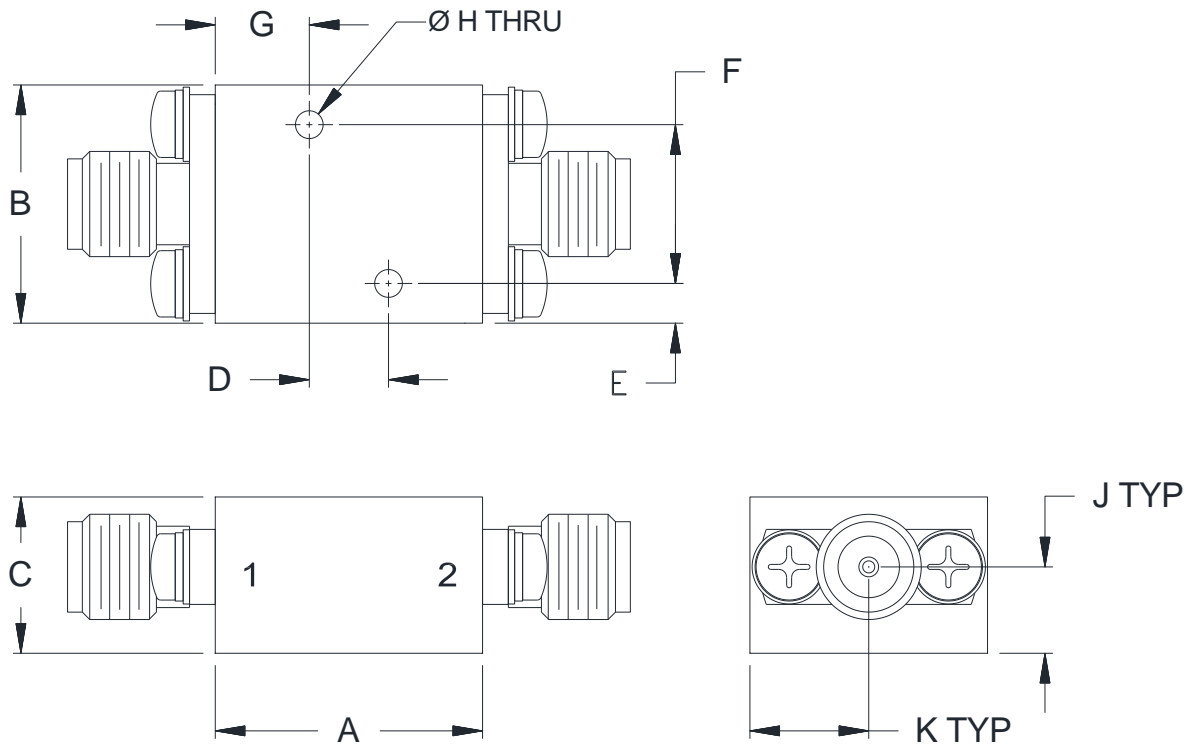

CASE#	A	B	C	D	E	F
UK3042	.68 (17.1)	.60 (15.2)	.39 (10.0)	.200 (5.08)	.10 (2.5)	.400 (10.16)

CASE#	G	H	J	K	WT.GRAMS
UK3042	.24 (6.0)	.070 (1.78)	.22 (5.5)	.30 (7.6)	24

Dimensions are in inches (mm). Tolerances: 2 Pl. $\pm .050$; 3 Pl. $\pm .015$

Notes:

1. Case material: Brass alloy.
2. Case Finish:
 - a. Case & Cover of the units –Gold plating.
3. Refer to the individual model data sheet for the type of connectors available.



P.O. Box 350166, Brooklyn, New York 11235-0003 (718) 934-4500 Fax (718) 332-4661 For detailed performance specs & shopping online see Mini-Circuits web site



The Design Engineers Search Engine Provides ACTUAL Data Instantly From MINI-CIRCUITS At: www.minicircuits.com

RF/IF MICROWAVE COMPONENTS

All Mini-Circuits products are manufactured under exacting quality assurance and control standards, and are capable of meeting published specifications after being subjected to any or all of the following physical and environmental test.

Specification	Test/Inspection Condition	Reference/Spec
Operating Temperature	-55° to 105°C Ambient Environment	Individual Model Data Sheet
Storage Temperature	-55° to 105°C Ambient Environment	Individual Model Data Sheet