

REPLACEMENT PART REFERENCE GUIDE, ZGDC20-33HP+

AN-30-013

ORIGINAL PART:	ZGDC20-33HP+	
REPLACEMENT PART:	ZGDC20-372HP+	

Replacement Part has been judged by Mini-Circuits Engineering as a suitable replacement to Original Part.

MECHANICAL DIMENSIONS

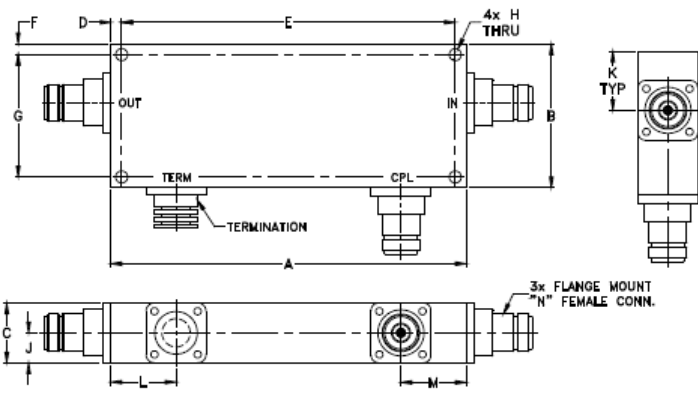
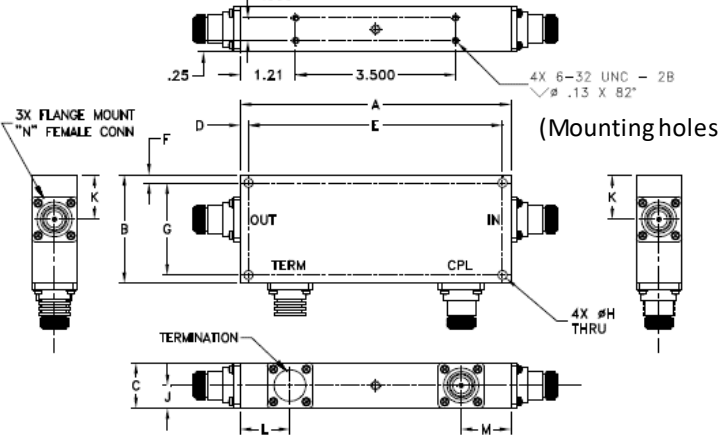
ORIGINAL PART: ZGDC20-33HP+	REPLACEMENT PART: ZGDC20-372HP+															
<p style="text-align: center; color: #00AEEF; font-weight: bold;">Case Style HT1412</p> 	<p style="text-align: center; color: #00AEEF; font-weight: bold;">Case Style HT1398-3</p> 															
<p>*Replacement part has additional mounting holes as shown.</p> <p>*Updates in dimension sizes are noted in the table. All other dimension sizes are equal.</p> <table border="1" style="margin-left: auto; margin-right: auto; border-collapse: collapse; text-align: center;"> <thead> <tr> <th style="background-color: #00AEEF; color: white;">Dimension</th> <th style="background-color: #FFD700;">ZGBDC20-33HP+</th> <th style="background-color: #00FF00;">ZGBDC20-372HP+</th> </tr> </thead> <tbody> <tr> <td>A</td> <td>5.58 in.</td> <td>5.93 in.</td> </tr> <tr> <td>B</td> <td>2.50 in.</td> <td>2.40 in.</td> </tr> <tr> <td>E</td> <td>5.215 in.</td> <td>5.565 in.</td> </tr> <tr> <td>G</td> <td>2.140 in.</td> <td>2.040 in.</td> </tr> </tbody> </table>		Dimension	ZGBDC20-33HP+	ZGBDC20-372HP+	A	5.58 in.	5.93 in.	B	2.50 in.	2.40 in.	E	5.215 in.	5.565 in.	G	2.140 in.	2.040 in.
Dimension	ZGBDC20-33HP+	ZGBDC20-372HP+														
A	5.58 in.	5.93 in.														
B	2.50 in.	2.40 in.														
E	5.215 in.	5.565 in.														
G	2.140 in.	2.040 in.														

CONCLUSION:

1) FORM-FIT-FUNCTIONAL ANALYSIS_a:

The replacement part has minor dimensional changes, see page 1.

Following is a summary of changes/improvements in the electrical specification:

Parameter	ZGDC20-33HP+ (Original Part)		ZGDC20-372HP+ (Replacement Part)	
	Frequency (MHz)	Spec	Frequency (MHz)	Spec
Frequency (MHz)	300-3000		300-3700	
Coupling Flatness, Max (±)	300-700	3.0	300-380	1.5
	700-2700	0.75	380-600	2.0
	2700-3000	0.5	600-2700	0.75
Mainline Loss, Max (dB)	300-700	0.2	2700-3700	0.5
	700-2700	0.3	300-380	0.2
	2700-3000	0.35	380-600	0.2
Directivity, Min (dB)	300-700	20	600-2700	0.3
	700-2700	15	2700-3700	0.4
	2700-3000	15	300-380	20
Input Power, Max (W)	300-700	250	380-600	20
	700-2700	250	600-2700	15
	2700-3000	160	2700-3700	14
Weatherproof	300-3000	IP67	300-3700	250
				250
				250
				150
				None

For typical performance and Graphs: See paragraphs 2 and 3

2) TYPICAL PERFORMANCE COMPARISON AT ROOM TEMPERATURE:

MODEL: ZGDC20-33HP+ (RF Parameters)

For typical performance and Graphs: See paragraphs 2 and 3

RF Parameters	Frequency (MHz)		Original Design @ 15 Units			Replacement Design @ 10 Units		
	Low	High	Min	Ave	Max.	Min.	Ave.	Max
Coupling (dB)	300	380	23.3	24.4	25.6	22.5	23.5	24.6
	380	600	20.7	22.5	23.9	20.5	21.5	23.0
	600	700	20.2	20.8	21.4	20.2	20.5	20.9
	700	2700	19.8	20.4	20.9	20.1	20.6	21.1
	2700	3000	19.8	20.3	20.5	20.6	20.9	21.2
	3000	3700	-	-	-	20.6	20.9	21.4
Coupling Flatness (±)	300	380	0.83	0.84	0.84	0.78	0.79	0.80
	380	600	1.24	1.25	1.27	1.04	1.07	1.10
	600	700	0.24	0.24	0.25	0.14	0.14	0.16
	700	2700	0.16	0.20	0.25	0.23	0.27	0.31
	2700	3000	0.02	0.04	0.05	0.09	0.12	0.15
	3000	3700	-	-	-	0.12	0.15	0.18
Insertion Loss (dB)	300	380	0.02	0.03	0.03	0.02	0.03	0.03
	380	600	0.03	0.03	0.05	0.03	0.03	0.04
	600	700	0.04	0.04	0.05	0.03	0.04	0.05
	700	2700	0.04	0.08	0.15	0.04	0.09	0.14
	2700	3000	0.11	0.14	0.18	0.13	0.14	0.15
	3000	3700	-	-	-	0.14	0.16	0.20
Directivity (dB)	300	380	24.7	27.3	29.4	30.4	36.4	47.7
	380	600	25.2	27.6	30.1	32.5	39.5	55.3
	600	700	25.5	28.1	31.0	30.2	43.1	73.6
	700	2700	18.3	25.9	39.4	16.2	27.0	56.1
	2700	3000	18.1	23.8	40.1	16.5	23.1	48.4
	3000	3700	-	-	-	14.9	20.1	48.4
Input Return Loss (dB)	300	380	27.1	29.6	33.2	28.0	33.6	44.2
	380	600	27.7	35.7	72.1	28.1	37.5	52.7
	600	700	32.8	39.9	72.1	29.5	37.0	53.2
	700	2700	25.3	38.4	62.3	25.5	35.9	70.9
	2700	3000	24.4	33.7	46.8	24.0	28.7	36.3
	3000	3700	-	-	-	23.1	32.3	45.3
Output Return Loss (dB)	300	380	27.3	29.6	33.7	28.1	34.2	48.4
	380	600	27.6	34.5	63.8	28.5	37.9	51.4
	600	700	36.4	43.0	63.8	28.8	35.8	52.3
	700	2700	23.3	34.8	67.1	24.7	35.3	62.7
	2700	3000	22.1	28.0	41.8	23.3	27.8	36.7
	3000	3700	-	-	-	23.1	34.1	69.4
Coupling Return Loss (dB)	300	380	25.1	28.1	30.8	28.3	34.2	44.5
	380	600	25.1	28.6	35.3	28.1	32.8	41.8
	600	700	26.8	30.9	35.3	29.5	34.8	46.2
	700	2700	17.7	26.6	39.3	23.1	32.3	55.8
	2700	3000	16.6	18.4	21.0	22.3	30.4	44.5
	3000	3700	-	-	-	20.0	28.8	50.4

3) TYPICAL PERFORMANCE GRAPHS AT ROOM TEMPERATURE:

MODELS: ZGDC20-33HP+ (Original Part) & ZGDC20-372HP+ (Replacement Part)

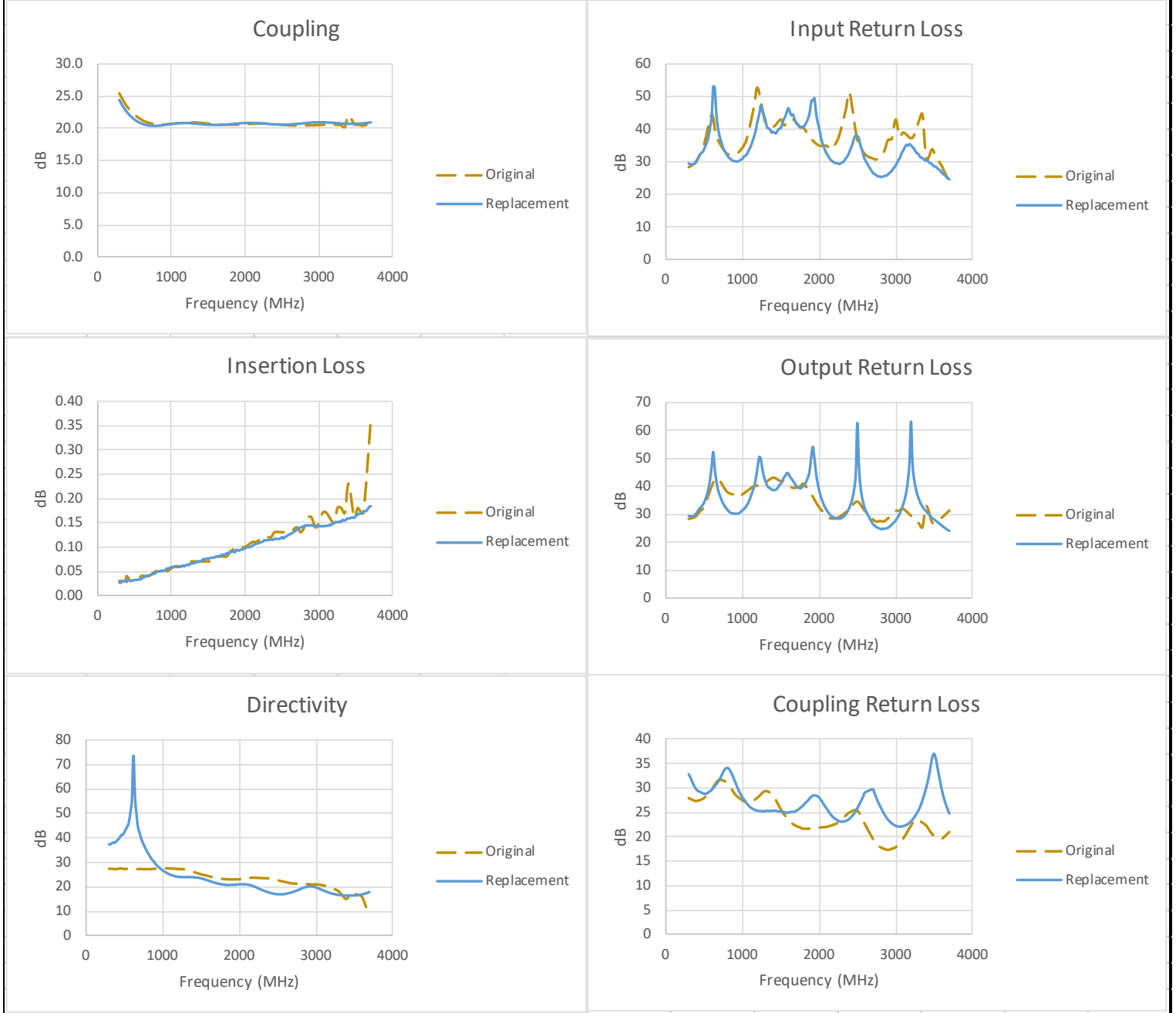



© 2015 Mini-Circuits

IMPORTANT NOTICE

This document is provided as an accommodation to Mini-Circuits customers in connection with Mini-Circuits parts only. In that regard, this document is for informational and guideline purposes only. Mini-Circuits assumes no responsibility for errors or omissions in this document or for any information contained herein.

Mini-Circuits may change this document or the Mini-Circuits parts referenced herein (collectively, the "Materials") from time to time, without notice. Mini-Circuits makes no commitment to update or correct any of the Materials, and Mini-Circuits shall have no responsibility whatsoever on account of any updates or corrections to the Materials or Mini-Circuits' failure to do so. Mini-Circuits customers are solely responsible for the products, systems, and applications in which Mini-Circuits parts are incorporated or used. In that regard, customers are responsible for consulting with their own engineers and other appropriate professionals who are familiar with the specific products and systems into which Mini-Circuits' parts are to be incorporated or used so that the proper selection, installation/integration, use and safeguards are made. Accordingly, Mini-Circuits assumes no liability therefore.

In addition, your use of this document and the information contained herein is subject to Mini-Circuits' standard terms of use, which are available at Mini-Circuits' website at www.minicircuits.com/homepage/terms_of_use.html.

Mini-Circuits and the Mini-Circuits logo are registered trademarks of Scientific Components Corporation d/b/a Mini-Circuits. All other third-party trademarks are the property of their respective owners. A reference to any third-party trademark does not constitute or imply any endorsement, affiliation, sponsorship, or recommendation: (i) by Mini-Circuits of such third-party's products, services, processes, or other information; or (ii) by any such third-party of Mini-Circuits or its products, services, processes, or other information.