

### LTE Base Station MMIC Amplifier

Mini-Circuits GVA-82+ High Dynamic Range MMIC Amplifier is designed specifically for applications which require high linear performance, particularly wideband, advanced digital communications systems such as LTE which require excellent ACLR suppression and low EVM.

The GVA-82+ provides typically +38 dBm OIP3 which translates to high linear performance in multi-carrier and complex signal environments such as LTE supporting ACLR<sub>1</sub> Measurements of better than -60 dBc at +8 dBm output.

The GVA-82+ is characterized using a high peak-to-average ratio OFDM signal used for next generation LTE within the 700MHz Downlink Band.



Figure 1 (GVA-82+ Test Board)

**DUT Configuration:**

**Device:** GVA-82+ Test board

**Supply Voltage:** 5V, 105 mA

**Temperature:** 25C

**Note:** All data is referenced to the test board connectors

**Test Signal:**

LTE FDD Downlink (2009-3), Full filled 64 QAM, 10MHz (50 RB) Fc = 700 MHz

CCDF	PAR
10%	3.63 dB
1.0%	6.67 dB
0.1%	8.48 dB
0.01%	10.06 dB
0.001%	10.90 dB
0.0001%	11.05 dB

CCDF: Complementary Cumulative Distribution Function  
PAR: Peak to Average Ratio

### Measurement Setup

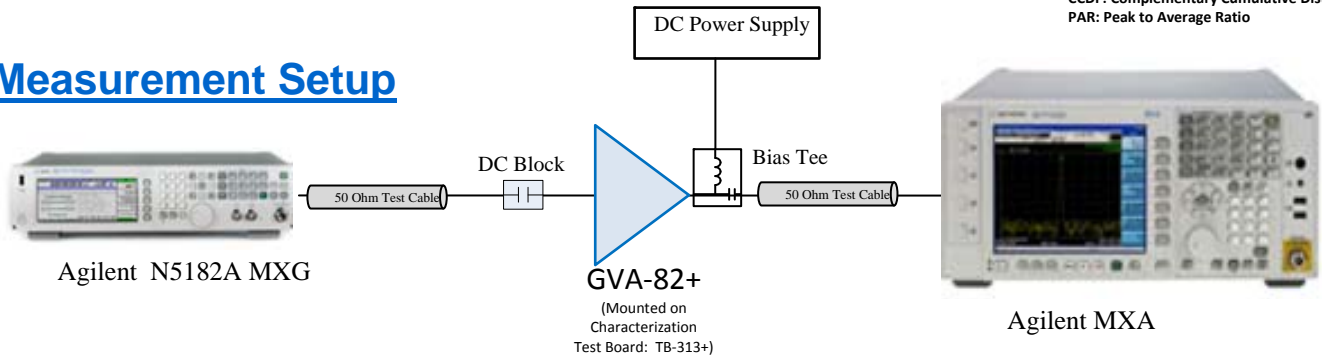

### Summary Data

#### ACLR 1 vs. Output Power

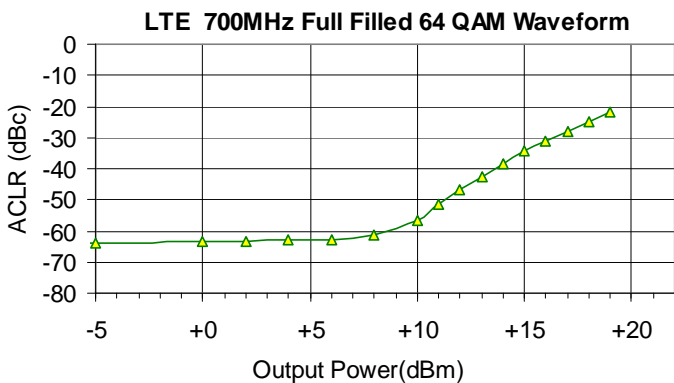

#### EVM vs. Output Power

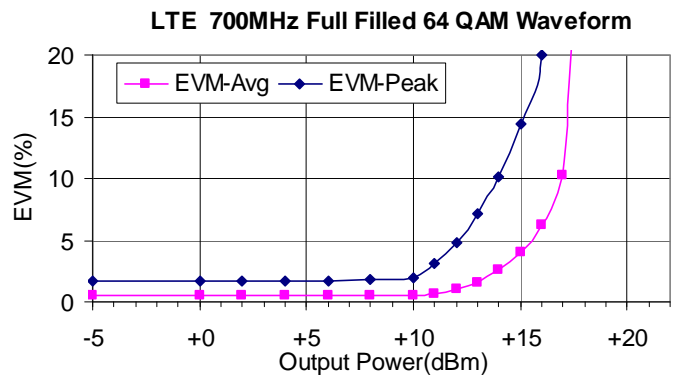

P.O. Box 350166, Brooklyn, New York 11235-0003 (718) 934-4500 Fax (718) 332-4661 For detailed performance specs & shopping online see Mini-Circuits web site



The Design Engineers Search Engine Provides ACTUAL Data Instantly From MINI-CIRCUITS At: [www.minicircuits.com](http://www.minicircuits.com)

RF/IF MICROWAVE COMPONENTS

Table 1 Data of ACLR and EVM vs. Output Power

Output Power (carrier) dBm	ACLR (dBc)				EVM (%)	
	ACLR2 LOW 20MHz	ACLR1 LOW 10MHz	ACLR1 HIGH 10MHz	ACLR2 HIGH 20MHz	RMS	Peak
+19	-43.3	-22.0	-21.8	-43.2	46.187	110.03
+18	-46.3	-24.9	-24.8	-46.2	37.880	97.65
+17	-49.3	-28.0	-27.9	-49.1	10.288	93.60
+16	-52.1	-31.2	-31.2	-52.0	6.188	19.99
+15	-54.8	-34.5	-34.6	-54.8	4.068	14.46
+14	-57.6	-38.3	-38.5	-57.5	2.596	10.11
+13	-60.1	-42.5	-42.7	-60.1	1.597	7.19
+12.29	-61.4	-44.7	-45.0	-61.1	1.258	6.03
+12	-62.2	-46.8	-47.1	-61.9	0.991	4.86
+11	-63.1	-51.5	-51.9	-63.1	0.678	3.06
+10	-63.7	-56.5	-56.6	-63.5	0.559	1.99
+8	-63.9	-61.3	-61.4	-63.7	0.493	1.86
+6	-63.8	-62.7	-62.6	-63.7	0.488	1.73
+4	-63.7	-63.1	-63.1	-63.7	0.486	1.75
+2	-63.7	-63.3	-63.3	-63.8	0.482	1.70
+0	-63.7	-63.5	-63.4	-63.7	0.477	1.74
-5	-63.7	-63.7	-63.5	-63.7	0.476	1.75

Note:  
For output powers less than -5dBm, ACLR measurement accuracy is limited by the dynamic range of the test equipment.

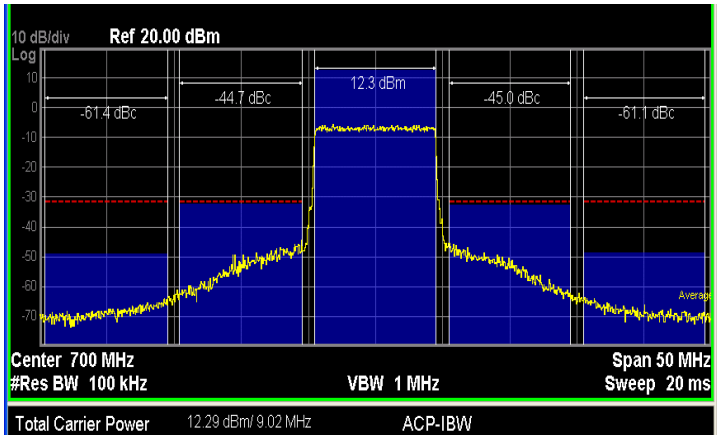

Figure 2 ACLR Plot at Output Power of +12.29 dBm

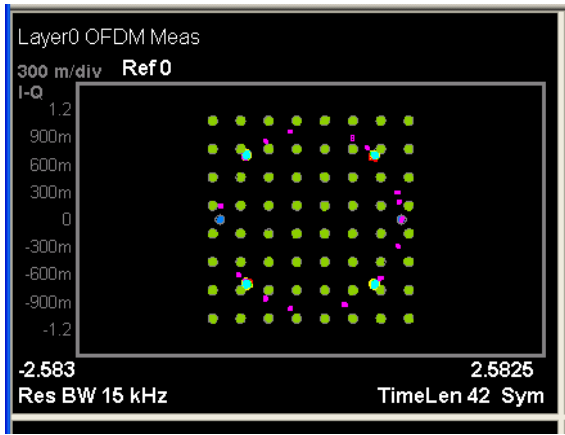

Figure 3 EVM Plot at Output Power of +12.29 dBm

### IMPORTANT NOTICE

© 2015 Mini-Circuits

This document is provided as an accommodation to Mini-Circuits customers in connection with Mini-Circuits parts only. In that regard, this document is for informational and guideline purposes only. Mini-Circuits assumes no responsibility for errors or omissions in this document or for any information contained herein.

Mini-Circuits may change this document or the Mini-Circuits parts referenced herein (collectively, the "Materials") from time to time, without notice. Mini-Circuits makes no commitment to update or correct any of the Materials, and Mini-Circuits shall have no responsibility whatsoever on account of any updates or corrections to the Materials or Mini-Circuits' failure to do so.

Mini-Circuits customers are solely responsible for the products, systems, and applications in which Mini-Circuits parts are incorporated or used. In that regard, customers are responsible for consulting with their own engineers and other appropriate professionals who are familiar with the specific products and systems into which Mini-Circuits' parts are to be incorporated or used so that the proper selection, installation/integration, use and safeguards are made. Accordingly, Mini-Circuits assumes no liability therefor.

In addition, your use of this document and the information contained herein is subject to Mini-Circuits' standard terms of use, which are available at Mini-Circuits' website at [www.minicircuits.com/homepage/terms\\_of\\_use.html](http://www.minicircuits.com/homepage/terms_of_use.html).

Mini-Circuits and the Mini-Circuits logo are registered trademarks of Scientific Components Corporation d/b/a Mini-Circuits. All other third-party trademarks are the property of their respective owners. A reference to any third-party trademark does not constitute or imply any endorsement, affiliation, sponsorship, or recommendation: (i) by Mini-Circuits of such third-party's products, services, processes, or other information; or (ii) by any such third-party of Mini-Circuits or its products, services, processes, or other information.



P.O. Box 350166, Brooklyn, New York 11235-0003 (718) 934-4500 Fax (718) 332-4661 For detailed performance specs & shopping online see Mini-Circuits web site



The Design Engineers Search Engine Provides ACTUAL Data Instantly From MINI-CIRCUITS At: [www.minicircuits.com](http://www.minicircuits.com)

RF/IF MICROWAVE COMPONENTS