

REPLACEMENT PART REFERENCE GUIDE, ZVBP-40600-K+

AN-75-034

ORIGINAL PART	ZVBP-40600-K+
REPLACEMENT PART	ZVBP-40600-K1+

Replacement Part has been judged by Mini-Circuits Engineering as a suitable replacement to Original Part

MECHANICAL DIMENSIONS

CASE STYLE	ZVBP-40600-K+	UH3130
	ZVBP-40600-K1+	ZT3578

CONCLUSION:

1. **FORM-FIT-FUNCTIONAL ANALYSIS:**

There is change in FORM, FIT and FUNCTION

FORM: There is change in color

ZVBP-40600-K+:



ZVBP-40600-K1+:



FIT:

ZVBP-40600-K+:

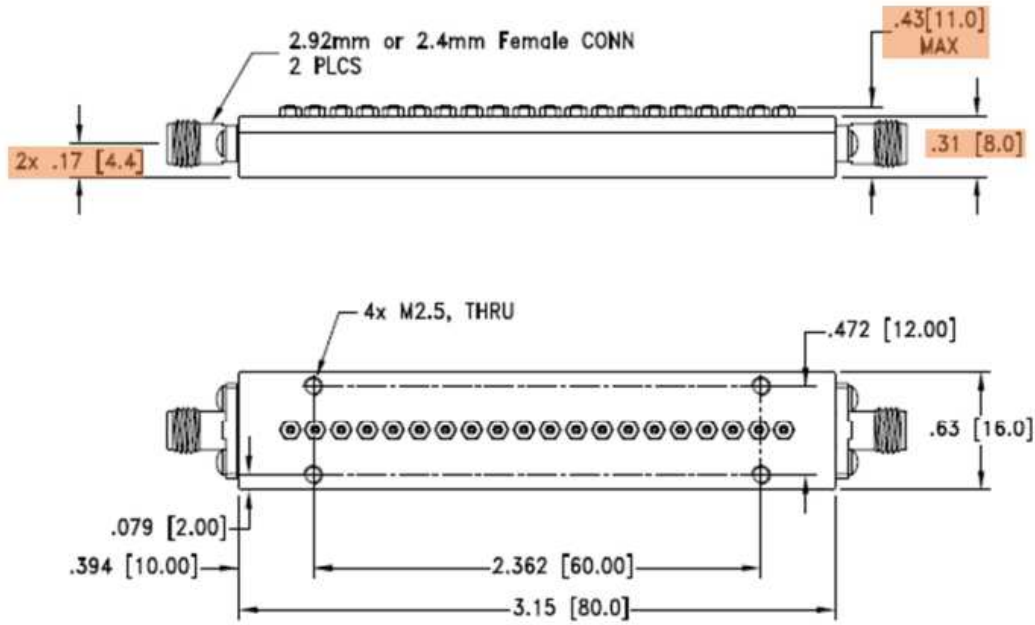

ZVBP-40600-K1+:

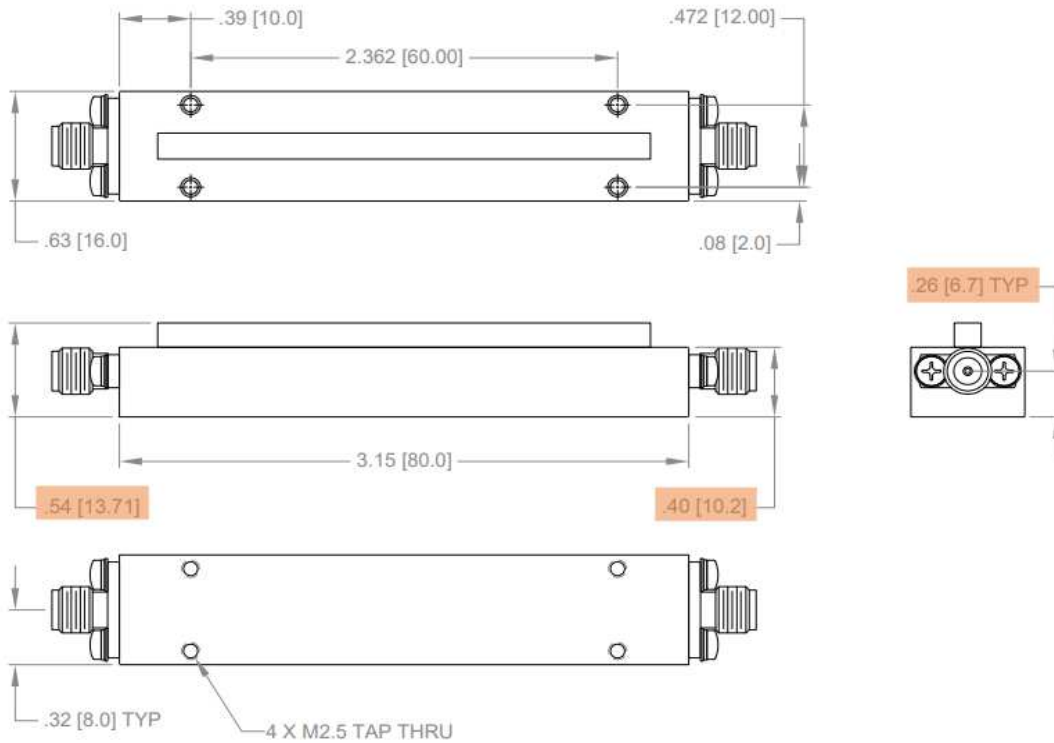

FUNCTION:

Following is the summary of changes/ improvements in the specification:

Electrical Parameters	Frequency, MHz		Catalog Specification					
			ZVBP-40600-K+			ZVBP-40600-K1+		
	Min	Max	MIN	TYP	MAX	MIN	TYP	MAX
Pass Band Insertion Loss (dB)	37700	43500	-	1.3	3.0	-	1.8	3.0
Pass Band Return Loss (dB)	37700	43500	15.0	28.0	-	15.0	18.0	-
Stop Band Rejection (dB)	DC	36600	80.0	102.0	-	70.0	88.0	-
Stop Band Rejection (dB)	44600	55000	80.0	114.0	-	70.0	79.0	-

For typical performance see paragraph 2

2. TYPICAL PERFORMANCE COMPARISON AT ROOM TEMPERATURE:

Electrical Parameters	Frequency, MHz		ZVBP-40600-K+		ZVBP-40600-K1+	
	Min	Max	MIN	MAX	MIN	MAX
Pass Band Insertion Loss (dB)	37700	43500	-	2.7	-	1.6
Pass Band Return Loss (dB)	37700	43500	20.0	-	17.9	-
Stop Band Rejection (dB)	DC	36600	103.0	-	89.1	-
Stop Band Rejection (dB)	44600	55000	86.6	-	89.1	-

IMPORTANT NOTICE

This document is provided as an accommodation to Mini-Circuits customers in connection with Mini-Circuits parts only. In that regard, this document is for informational and guideline purposes only. Mini-Circuits assumes no responsibility for errors or omissions in this document or for any information contained herein. Mini-Circuits may change this document or the Mini-Circuits parts referenced herein (collectively, the "Materials") from time to time, without notice. Mini-Circuits makes no commitment to update or correct any of the Materials, and Mini-Circuits shall have no responsibility whatsoever on account of any updates or corrections to the Materials or Mini-Circuits' failure to do so. Mini-Circuits customers are solely responsible for the products, systems, and applications in which Mini-Circuits parts are incorporated or used. In that regard, customers are responsible for consulting with their own engineers and other appropriate professionals who are familiar with the specific products and systems into which Mini-Circuits' parts are to be incorporated or used so that the proper selection, installation/integration, use and safeguards are made. Accordingly, Mini-Circuits assumes no liability therefore. In addition, your use of this document and the information contained herein is subject to Mini-Circuits' standard terms of use, which are available at Mini-Circuits' website at www.minicircuits.com/homepage/terms_of_use.html. Mini-Circuits and the Mini-Circuits logo are registered trademarks of Scientific Components Corporation d/b/a Mini-Circuits. All other third-party trademarks are the property of their respective owners. A reference to any third-party trademark does not constitute or imply any endorsement, affiliation, sponsorship, or recommendation: (i) by Mini-Circuits of such third-party's products, services, processes, or other information; or (ii) by any such third-party of Mini-Circuits or its products, services, processes, or other information.