

### Outline Dimensions

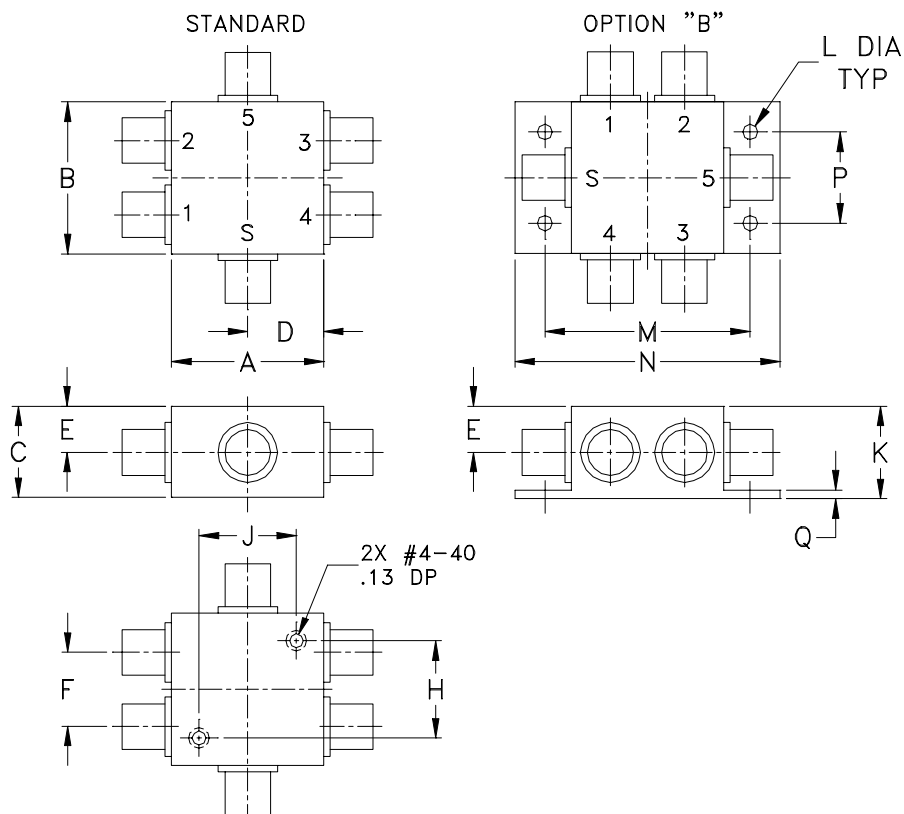

CASE #	A	B	C	D	E	F	G	H	J	K	L
G1170	1.25 (31.75)	1.25 (31.75)	.75 (19.05)	.63 (16.00)	.38 (9.65)	.61 (15.49)	--	.80 (20.32)	.80 (20.32)	.76 (19.30)	.125 (3.18)

CASE #	M	N	P	Q	WT. GRAM
G1170	1.688 (42.88)	2.18 (55.37)	.75 (19.05)	.07 (1.78)	85.0

Dimensions are in inches (mm). Tolerances: 2Pl.  $\pm .03$ ; 3 Pl.  $\pm .015$

#### Notes:

- Case material: Aluminum alloy.
- Case finish:  
For RoHS Case Styles: Clear chemical conversion coating, non-chrome or trivalent chrome based.
- Mounting bracket available on request. Add suffix B to part number.