

Outline Dimensions

LM1639

TOP VIEW

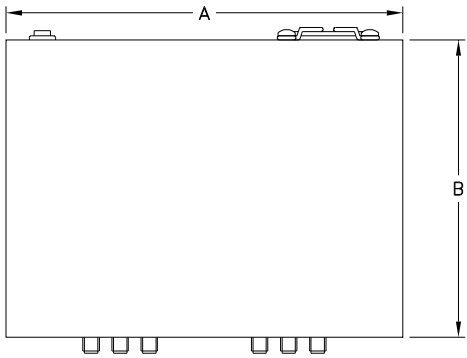

FRONT VIEW

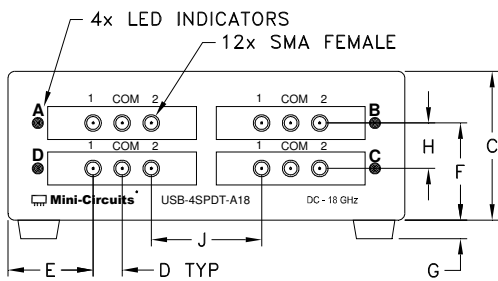

REAR VIEW

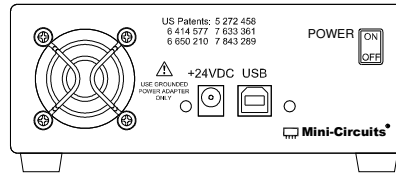

BOTTOM VIEW

Shown with Rubber feet removed and Brackets Installed.

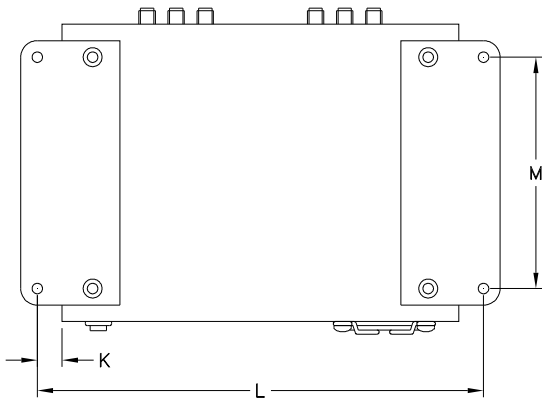

BRACKET OPTION
ONE SET OF 2 EACH.

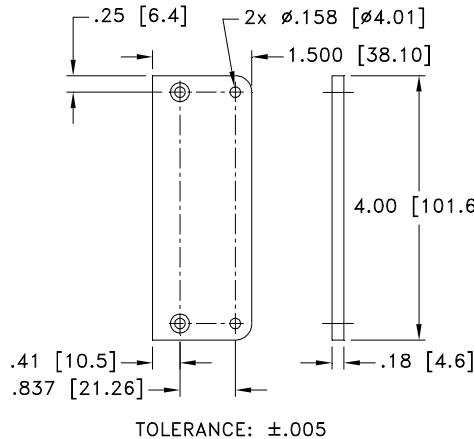

INSTRUCTION FOR MOUNTING BRACKETS:
TOOL REQUIRED:
PHILLIPS HEAD SCREW DRIVER
STEP 1: REMOVE RUBBER FEET FROM THE BOTTOM OF THE UNIT. DO NOT DISCARD THE FASTENERS.
STEP 2: MOUNT THE BRACKETS WITH THE FASTENERS REMOVED IN STEP 1, USING THE COUNTER-BORE HOLES IN THE BRACKET.

CASE#	A	B	C	D	E	F	G	H	J	K	L	M	WT. GRAMS
LM1639	6.00 (152.4)	4.50 (114.3)	2.25 (57.2)	.440 (11.18)	1.28 (32.5)	1.47 (37.3)	.28 (7.11)	.688 (17.5)	1.670 (42.4)	.375 (9.52)	6.75 (171.4)	3.500 (88.9)	1184

Dimensions are in inches (mm). Tolerances: 2PL. +/- .03; 3PL. +/- .015

Notes:

1. Case and Bracket material: Aluminum Alloy.
2. Finish: For Case- Powder coating. Color: Blue, For Bracket- Clear Chemical conversion coating.