

Outline Dimensions

PF2018

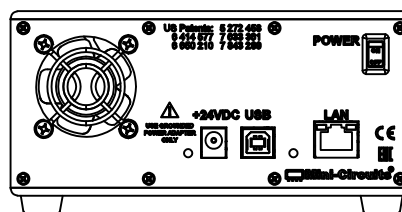
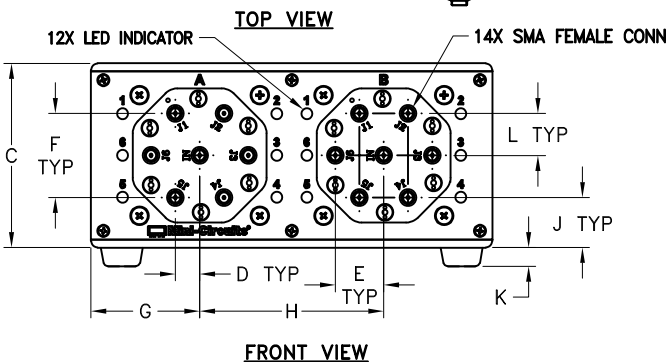
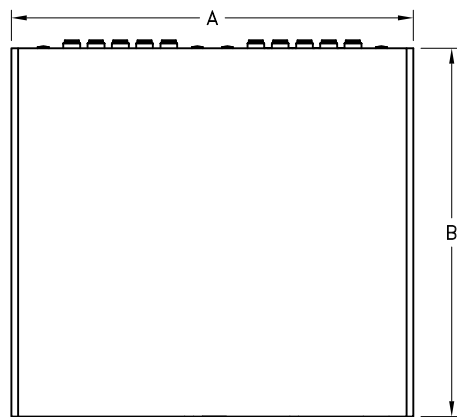

REAR VIEW

BRACKET OPTION
ONE SET OF 2 EACH

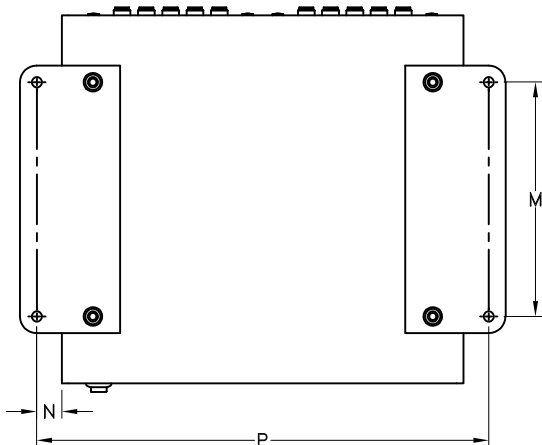

BOTTOM VIEW

SHOWN WITH RUBBER FEET REMOVED AND BRACKETS INSTALLED.

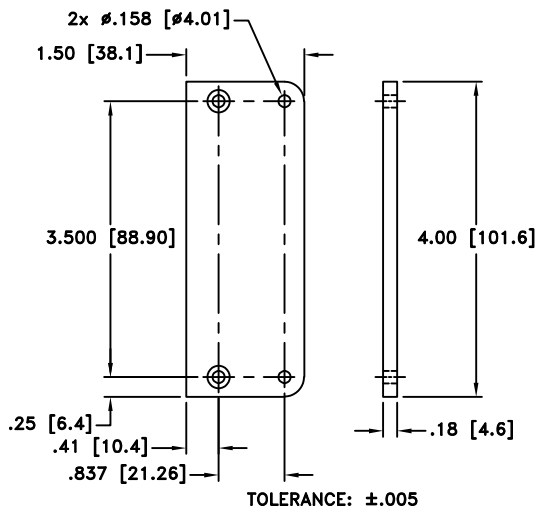

TOLERANCE: \pm .005

INSTRUCTION FOR MOUNTING BRACKETS:
TOOL REQUIRED: PHILLIPS HEAD SCREW DRIVER
STEP 1: REMOVE RUBBER FEET FROM THE BOTTOM OF THE UNIT, DO NOT DISCARD THE FASTENERS.
STEP 2: MOUNT THE BRACKETS WITH THE FASTENERS REMOVED IN STEP 1, USING THE COUNTER BORE HOLES IN THE BRACKET.

CASE#	A	B	C	D	E	F	G	H	J	K	L	M	N	P	WT. GRAMS
PF2018	6.00 (152.4)	5.50 (139.7)	2.75 (69.9)	.36 (9.21)	.725 (18.4)	1.26 (31.9)	1.625 (41.27)	2.75 (69.85)	.75 (19.0)	.28 (7.11)	.63 (15.95)	3.500 (88.90)	.375 (9.52)	6.75 (171.5)	1350

Dimensions are in inches (mm). Tolerances: 2 Pl. \pm .03; 3 Pl. \pm .015

Notes:

1. Case and Bracket material: Aluminum Alloy.
2. Finish: For Case- Powder coating. Color: Blue, For Bracket- Clear Chemical conversion coating.



P.O. Box 350166, Brooklyn, New York 11235-0003 (718) 934-4500 Fax (718) 332-4661 For detailed performance specs & shopping online see Mini-Circuits web site



The Design Engineers Search Engine Provides ACTUAL Data Instantly From MINI-CIRCUITS At: www.minicircuits.com

RF/IF MICROWAVE COMPONENTS