

TOP VIEW

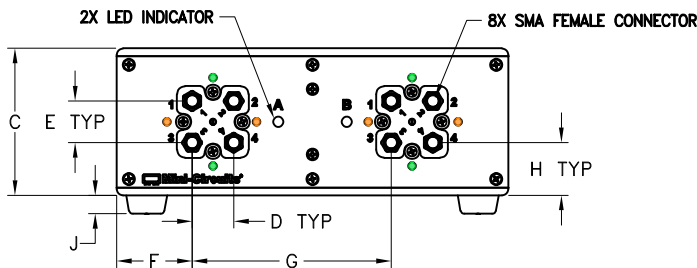

FRONT VIEW

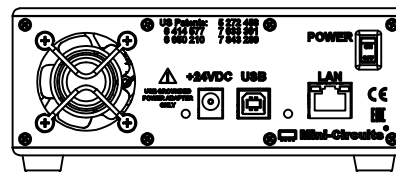

REAR VIEW

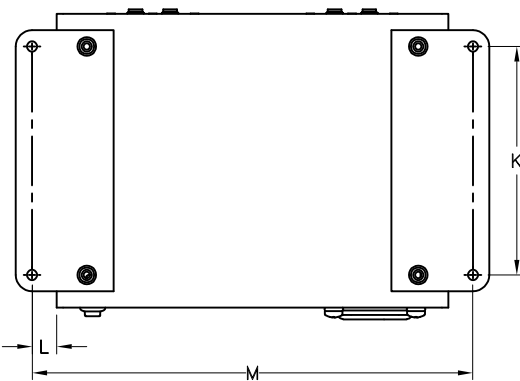

BOTTOM VIEW

SHOWN WITH RUBBER FEET REMOVED AND BRACKETS INSTALLED.

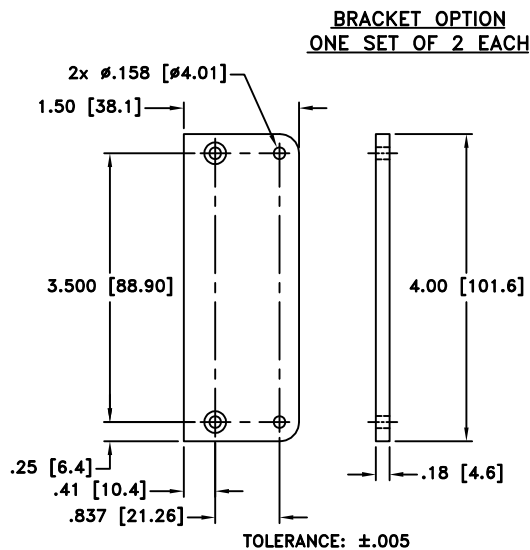

BRACKET OPTION
ONE SET OF 2 EACH

INSTRUCTION FOR MOUNTING BRACKETS:
TOOL REQUIRED: PHILLIPS HEAD SCREW DRIVER
STEP 1: REMOVE RUBBER FEET FROM THE BOTTOM OF THE UNIT, DO NOT DISCARD THE FASTENERS.
STEP 2: MOUNT THE BRACKETS WITH THE FASTENERS REMOVED IN STEP 1, USING THE COUNTER BORE HOLES IN THE BRACKET.

TOLERANCE: ±.005

| CASE# | A | B | C | D | E | F | G | H | J | K | L | M | WT. GRAMS |
|--------|-----------------|-----------------|----------------|---------------|---------------|----------------|----------------|---------------|--------------|-----------------|----------------|-------------------|-----------|
| SH3109 | 6.00 (152.4) | 4.50 (114.3) | 2.25 (57.2) | .64 (16.2) | .64 (16.2) | 1.16 (29.4) | 3.05 (77.5) | .81 (20.5) | .28 (7.1) | 3.50 (88.90) | .375 (9.52) | 6.750 (171.45) | 880 |

Dimensions are in inches (mm). Tolerances: 2 Pl.±.03; 3 Pl. ±.015

Notes:

1. Case and Bracket material: Aluminum Alloy.
2. Finish: For Case- Powder coating. Color: Blue, For Bracket- Clear Chemical conversion coating.



P.O. Box 350166, Brooklyn, New York 11235-0003 (718) 934-4500 Fax (718) 332-4661 For detailed performance specs & shopping online see Mini-Circuits web site



The Design Engineers Search Engine Provides ACTUAL Data Instantly From MINI-CIRCUITS At: www.minicircuits.com

RF/IF MICROWAVE COMPONENTS