

Outline Dimensions

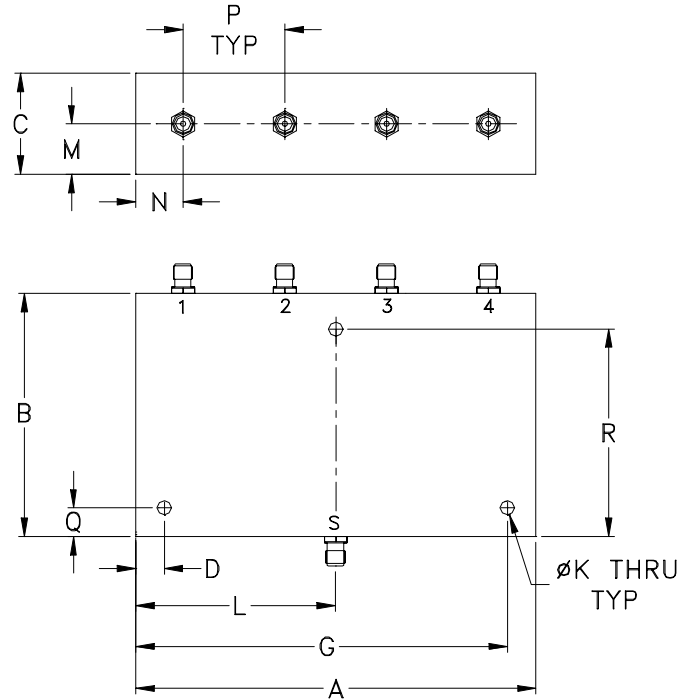

CASE#	A	B	C	D	E	F	G	H	J	K	L	M	N
Z54	3.50 (88.90)	2.13 (54.10)	.88 (22.35)	.250 (6.35)	--	--	3.250 (82.55)	--	--	.125 (3.17)	1.750 (44.45)	.44 (11.18)	.415 (10.54)

CASE#	P	Q	R	WT.GRAMS
Z54	.89 (22.61)	.250 (6.35)	1.813 (46.05)	250

Dimensions are in inches (mm). Tolerances: 2 Pl. $\pm .03$; 3 Pl. $\pm .015$

Notes:

- Case material: Aluminum alloy.
- Case finish:
For RoHS Case Styles: Clear chemical conversion coating, non-chrome or trivalent chrome based.



INTERNET <http://www.minicircuits.com>

P.O. Box 350166, Brooklyn, New York 11235-0003 (718) 934-4500 Fax (718) 332-4661

Distribution Centers NORTH AMERICA 800-654-7949 • 417-335-5935 • Fax 417-335-5945 • EUROPE 44-1252-832600 • Fax 44-1252-837010

Mini-Circuits ISO 9001 & ISO 14001 Certified