

THIRD ANGLE PROJECTION

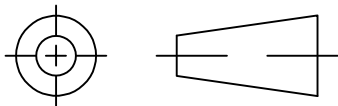

REVISIONS

REV	ECN No.	DESCRIPTION	DATE	DR	AUTH
OR	ECO-003662	NEW RELEASE	08/14/20	ITG	IL
A	ECO-026335	CHANGED POSITION OF PIN1	08/01/25	ITG	IL

SUGGESTED MOUNTING CONFIGURATION FOR
DQ1225 CASE STYLE

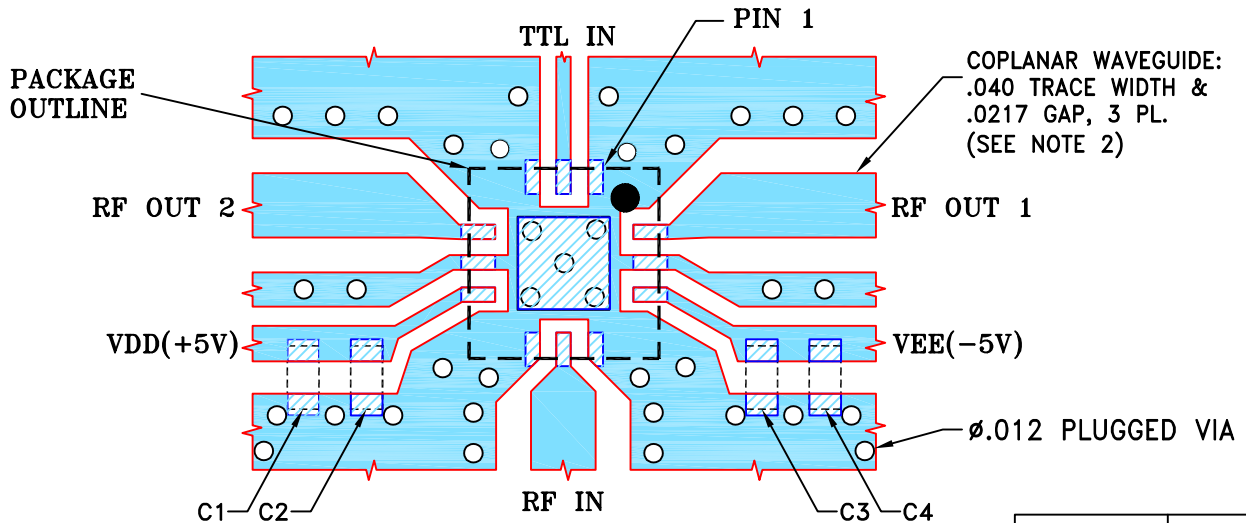

TOP VIEW

COMPONENT	SIZE
C1...C4	0402

STACK-UP DIAGRAM

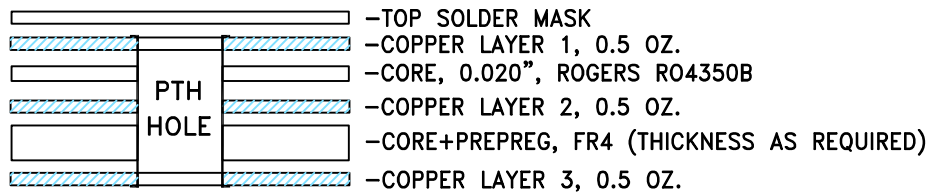

- TOTAL FINISHED THICKNESS 0.056" ± 10%.
- PTH HOLES PRESENT FROM COPPER LAYER 1 TO 3.

NOTES:

- PCB IS MULTILAYER PCB, SEE STACK-UP DIAGRAM.
- TRACE WIDTH & GAP PARAMETERS ARE SHOWN FOR ROGERS R04350B WITH DIELECTRIC THICKNESS .020±.0015"; COPPER: 1/2 OZ. FOR OTHER MATERIALS TRACE WIDTH AND GAP MAY NEED TO BE MODIFIED.
- CHIP COMPONENT FOOT PRINTS SHOWN FOR REFERENCE. FOR COMPONENT VALUES REFER TO TB-M3SWA263DRC+.
- UNIT LAND PATTERN WAS OPTIMIZED FOR BETTER PERFORMANCE.
- COPPER LAYERS L2 & L3 OF THE PCB ARE CONTINUOUS GROUND PLANES.

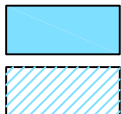

DENOTES PCB COPPER LAYOUT WITH SMOBC (SOLDER MASK OVER BARE COPPER)
DENOTES COPPER LAND PATTERN FREE OF SOLDER MASK

UNLESS OTHERWISE SPECIFIED	INITIALS	DATE
DIMENSIONS ARE IN INCHES	ITG	08/11/20
TOLERANCES ON:	GF	08/11/20
2 PL DECIMALS ±	IL	08/14/20
3 PL DECIMALS ± .005		
ANGLES ±		
FRACTIONS ±		



Mini-Circuits®

13 Neptune Avenue
Brooklyn NY 11235

PL, DQ1225, TB-M3SWA263DRC+

Mini-Circuits®
THIS DOCUMENT AND ITS CONTENTS ARE THE PROPERTY OF MINI-CIRCUITS. EXCEPT FOR USE EXPRESSLY GRANTED, IN WRITING, TO ITS VENDORS, VENDEE AND THE UNITED STATES GOVERNMENT, MINI-CIRCUITS RESERVES ALL PROPRIETARY DESIGN, USE, MANUFACTURING AND REPRODUCTION RIGHTS THERETO. THESE CONTENTS SHALL NOT BE USED, DUPLICATED OR DISCLOSED TO ANY OUTSIDE PARTY, IN WHOLE OR IN PART, WITHOUT WRITTEN PERMISSION OF MINI-CIRCUITS.

SIZE	CODE IDENT	DRAWING NO:	REV:
A	15542	98-PL-682	A
FILE:	98PL682	SCALE:	SHEET:
		8:1	1 OF 1