

Evaluation Board and Circuit

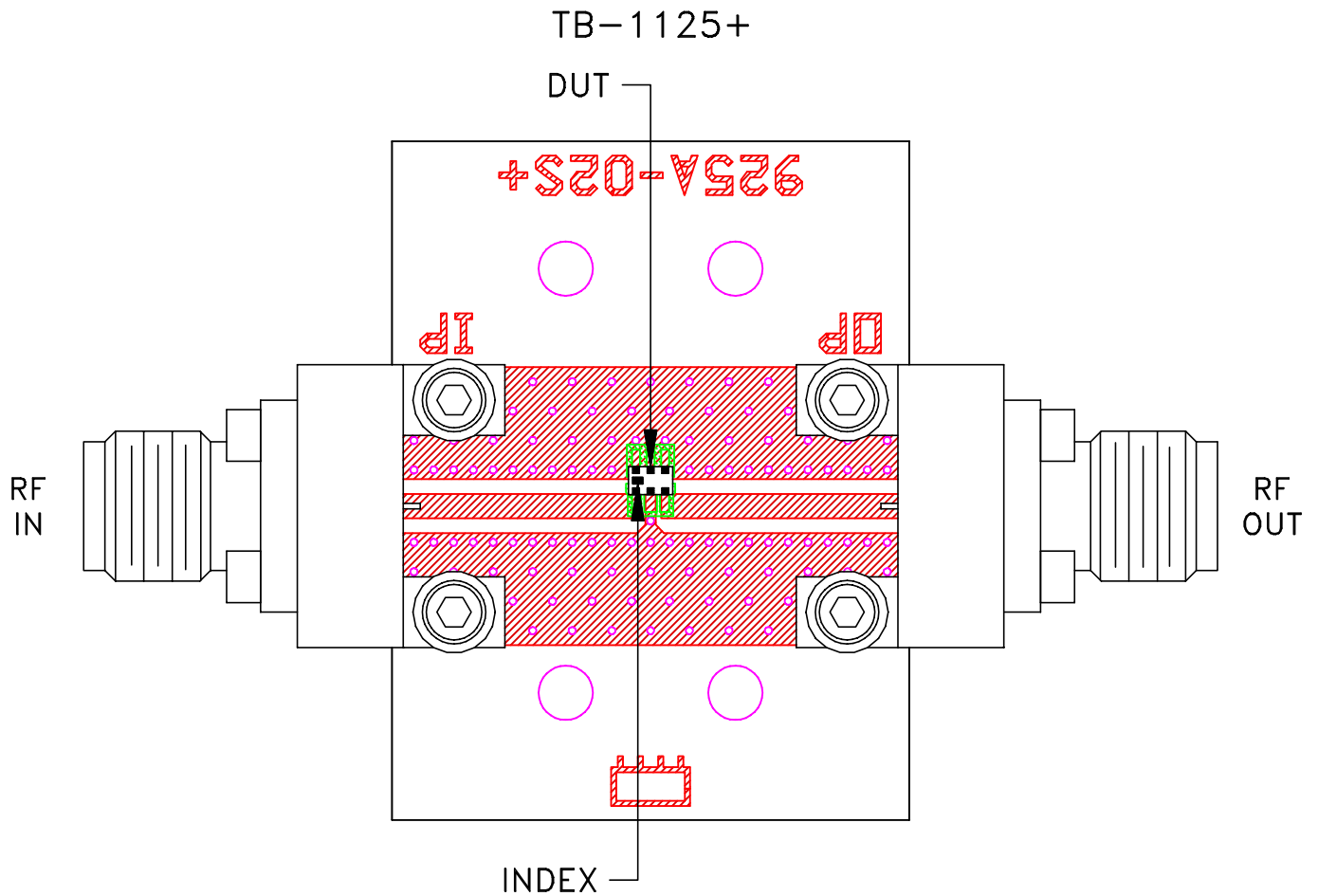

Schematic diagram

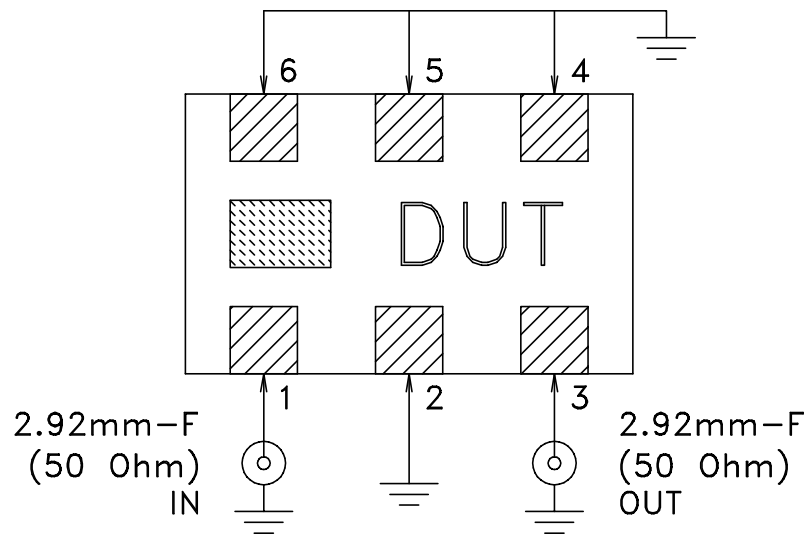

Notes:

1. PCB Material: ROGERS (RO4350B) OR Equivalent, Dielectric Constant= $3.48 \pm .05$
Dielectric Thickness: .020
2. 50 Ohm 2.92mm Female Connectors.

