

Evaluation Board and Circuit

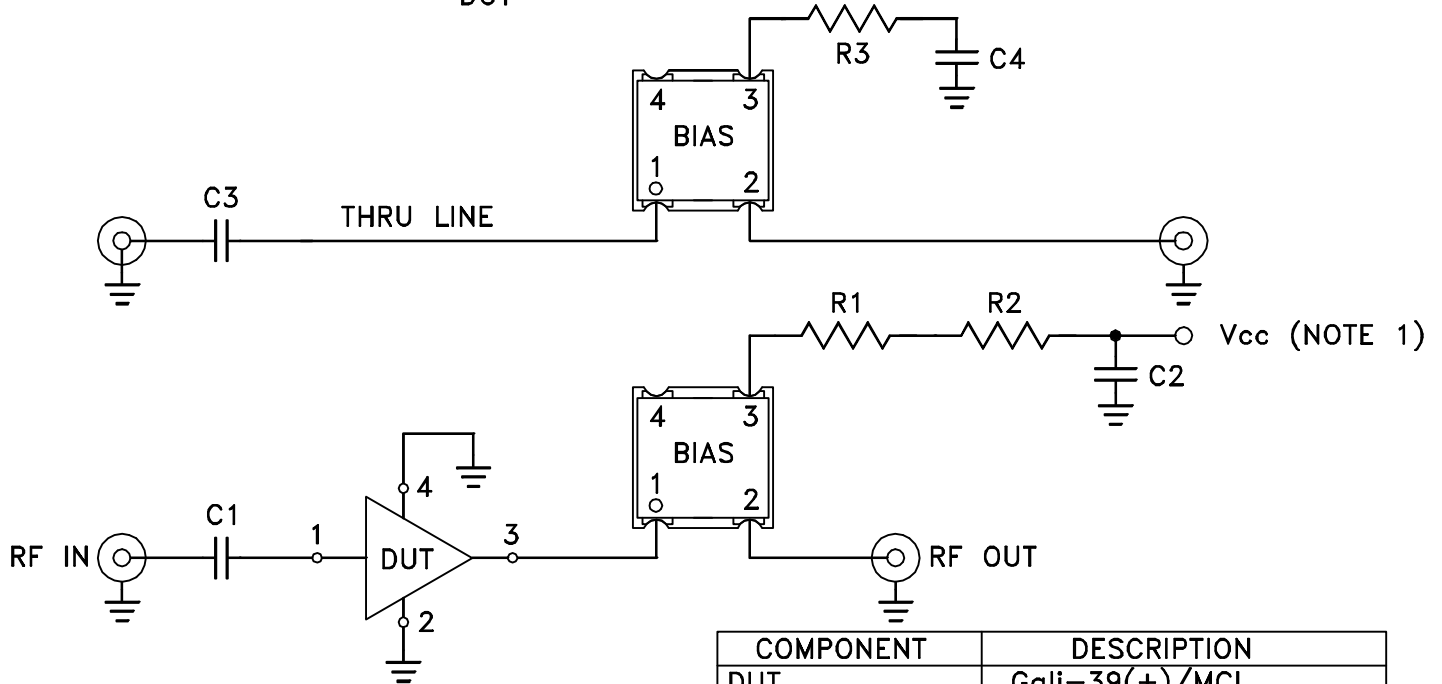
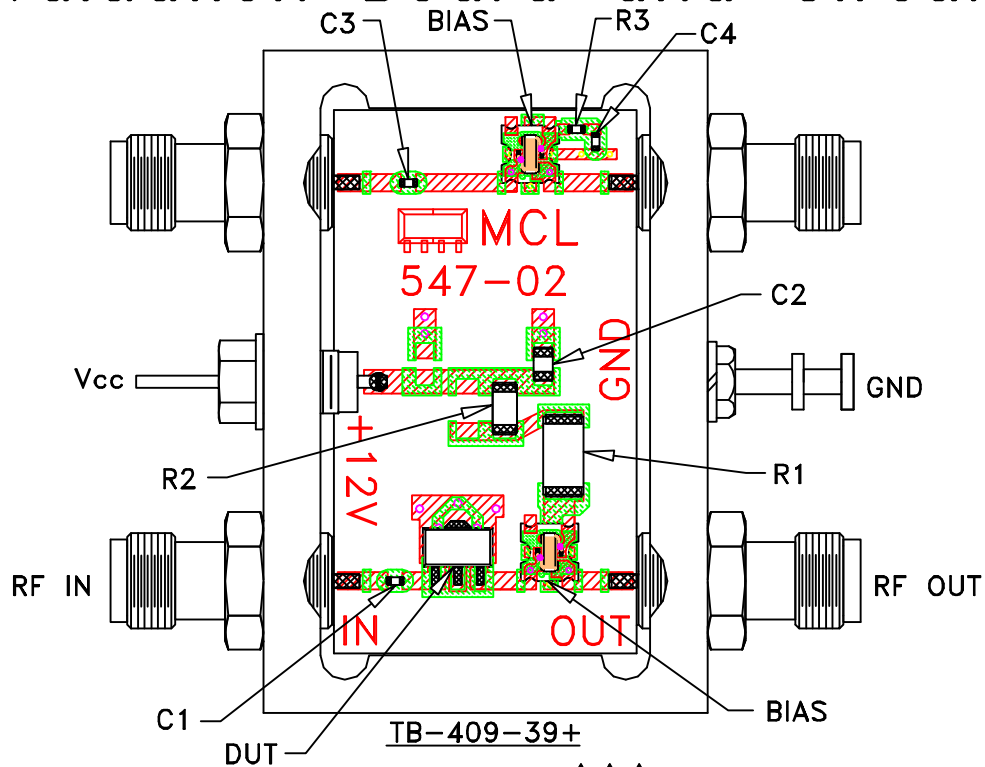

COMPONENT	DESCRIPTION
DUT	Gali-39(+)/MCL
C1,C3,C4	0.001 uF
C2 (bypass)	0.1 uF
R1	243 Ohms
R2	0 Ohm
R3	237 Ohms
BIAS TEE	Mini-Circuits TCBT-14+

NOTES:

1. Vcc voltage: $+12 \pm 0.2V$.
2. SMA Female connectors.
3. PCB material: Rogers R04350 or equivalent, dielectric constant=3.5, dielectric thickness=.020 inch.

Schematic Diagram

 **Mini-Circuits®**