

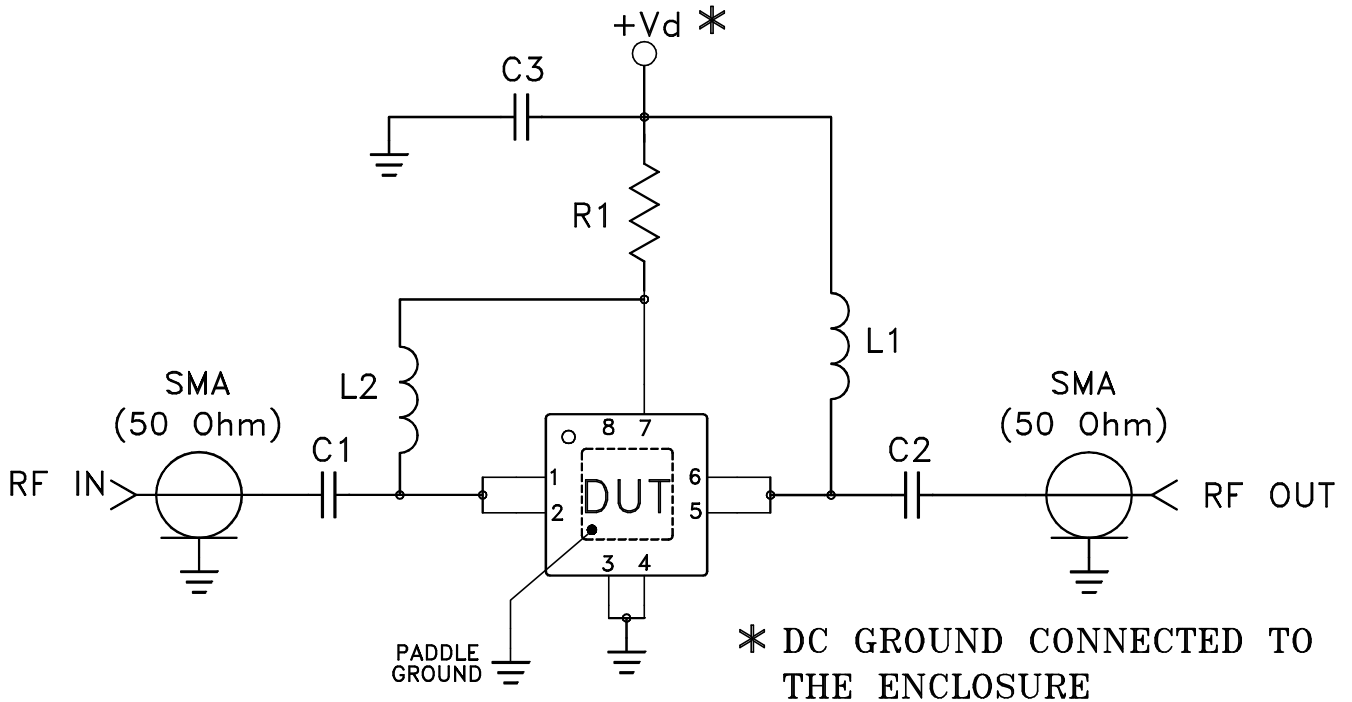

# Evaluation Board and Circuit

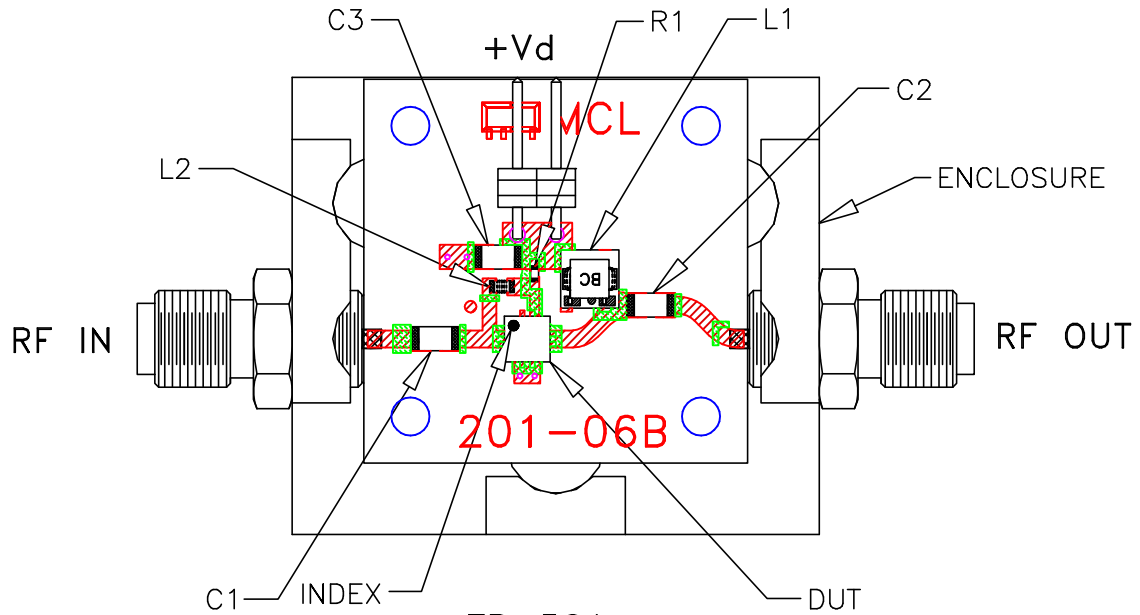

COMPONENT	VALUE/PART NUMBER
DUT	Mini-Circuits PMA-545+
C1, C2, C3	0.1 uF
L1	Mini-Circuits TCCH-80+
L2	390 nH
R1	432 Ohm

## Notes:

- 50 Ohm SMA Female connectors.
- PCB Material: R04350 or equivalent, Dielectric Constant=3.5, Thickness=.020 inch.

 **Mini-Circuits®**