

# Evaluation Board and Circuit

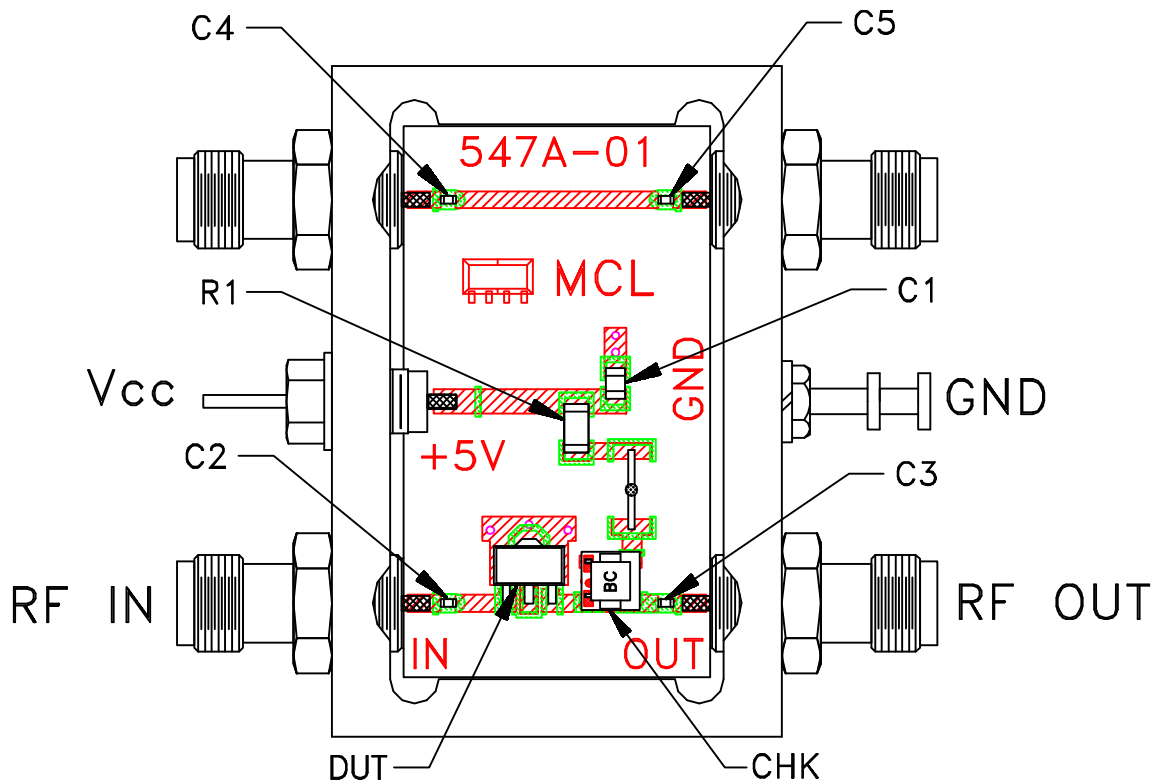

TB-545-1+

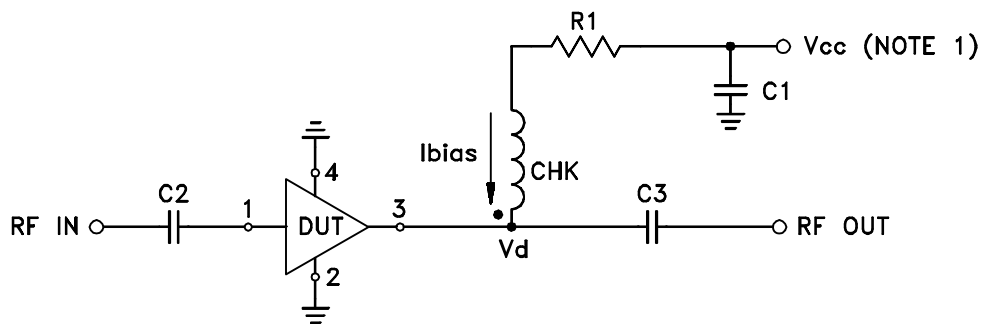

COMPONENT	VALUE
DUT	PHA-1+
C1 (bypass)	0.1 uF
C2-C5 (Note 4)	0.001 uF
R1	0 Ohm, 0.25W
CHK	Mini-Circuits TCCH-80+

Schematic Diagram

## NOTES:

1. Vcc voltage:  $+5 \pm 0.2V$ .
2. SMA Female connectors.
3. PCB material: Rogers R04350 or equivalent, dielectric constant=3.5, dielectric thickness=.020 inch.
4. Capacitor C2-C5 should be free of resonance up to the highest frequency specified.

 **Mini-Circuits®**