

Evaluation Board and Circuit

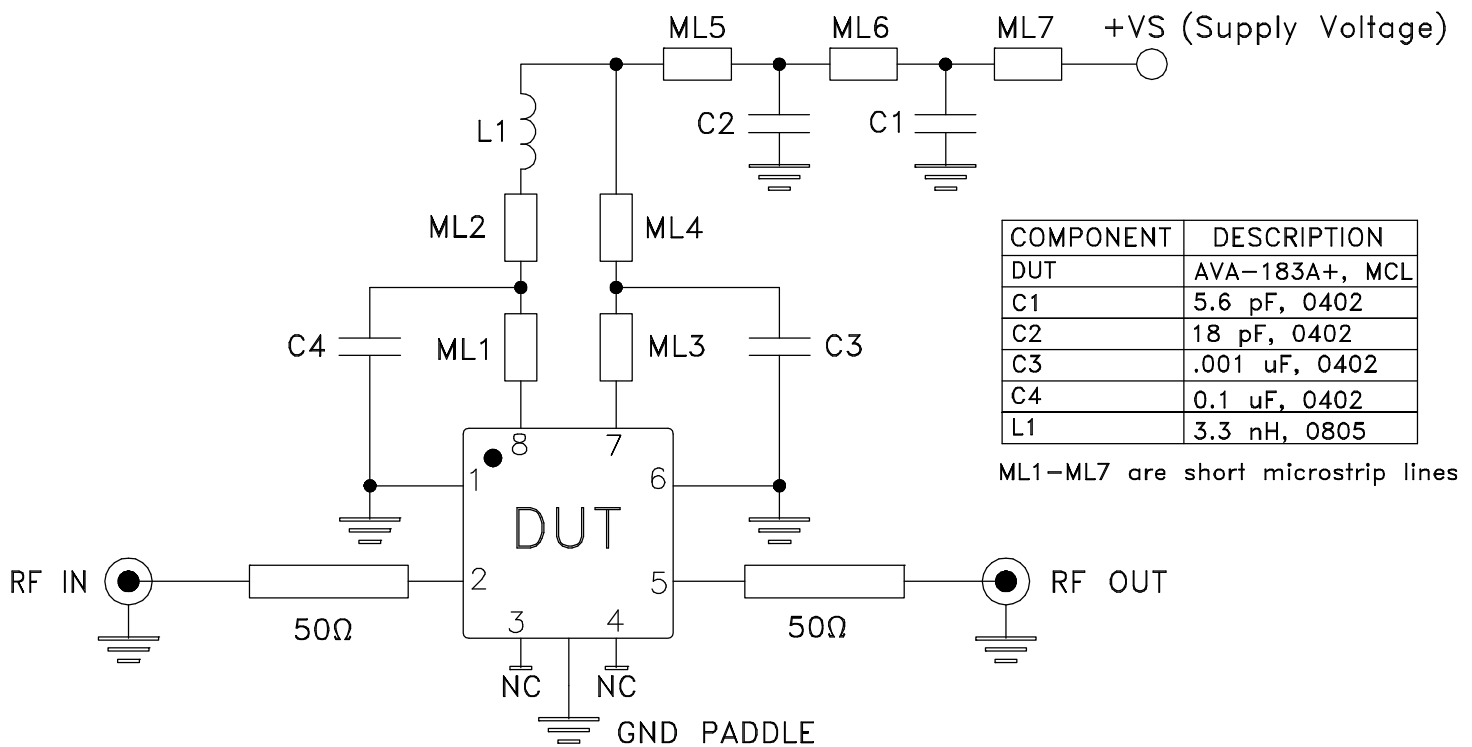
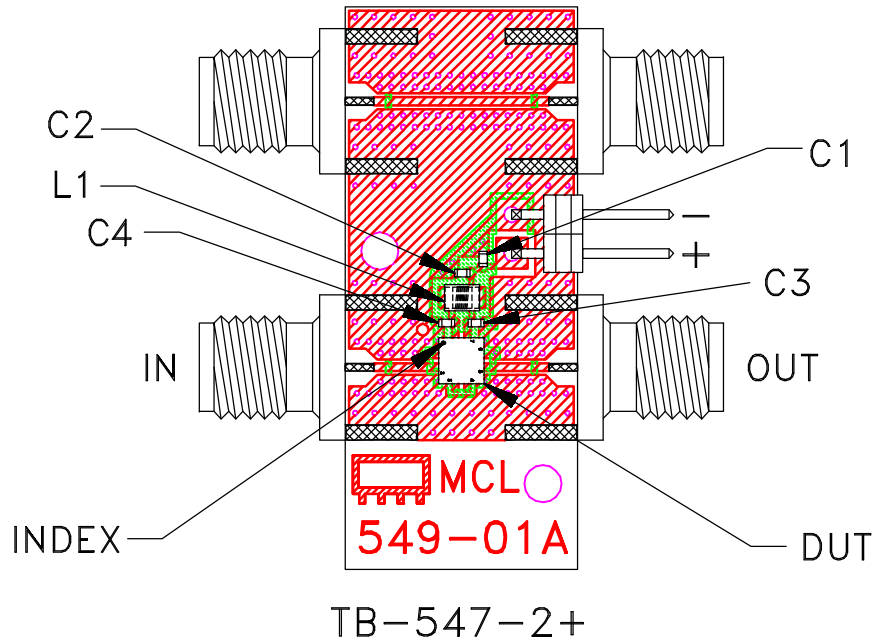

Schematic Diagram

NOTES:

1. SMA Female connectors.
2. PCB material: Rogers R04350 or equivalent, dielectric constant=3.5, dielectric thickness=.010 inch.

