

Evaluation Board and Circuit

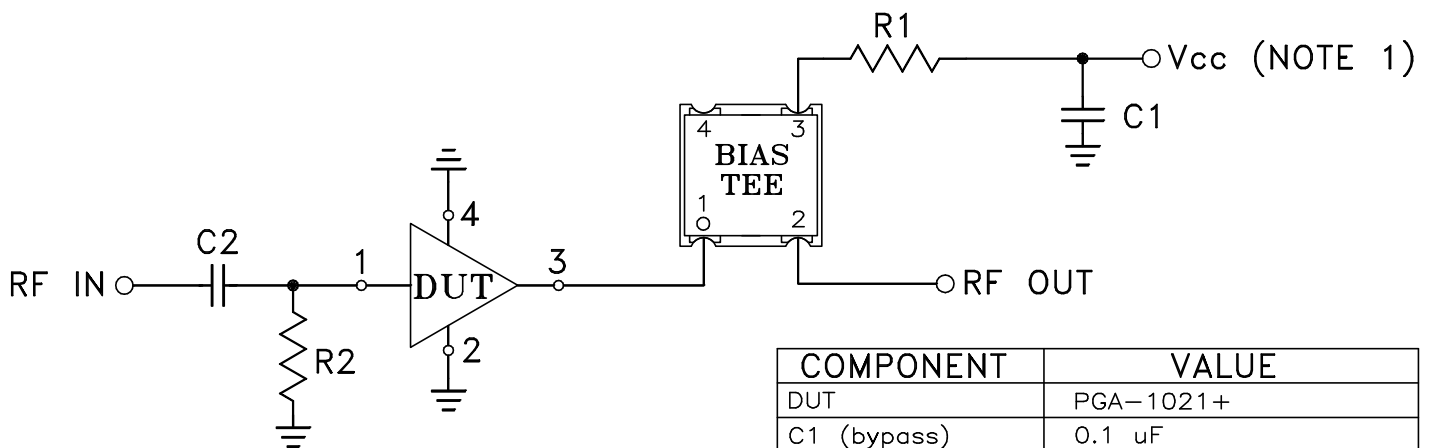
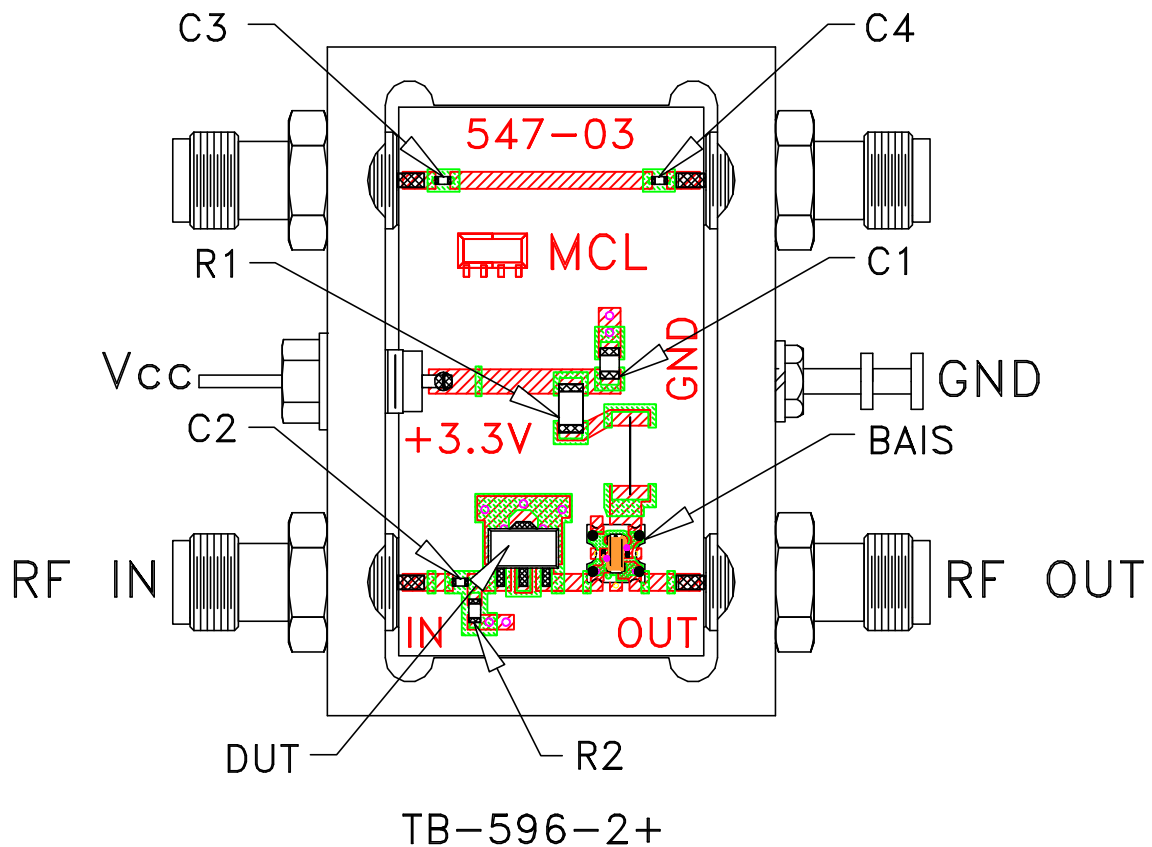

COMPONENT	VALUE
DUT	PGA-1021+
C1 (bypass)	0.1 uF
C2-C4 (Note 4)	0.001 uF
R1	0 Ohm, 0.25W
R2	2.37K Ohm, 0.1W
BIAS TEE	Mini-Circuits TCBT-14+

Schematic Diagram

NOTES:

1. Vcc voltage: $+3.3 \pm 0.2V$.
2. SMA Female connectors.
3. PCB material: Rogers R04350 or equivalent, dielectric constant=3.5, dielectric thickness=.020 inch.
4. Capacitor C2-C4 should be free of resonance up to the highest frequency specified.

 **Mini-Circuits®**