

Evaluation Board and Circuit

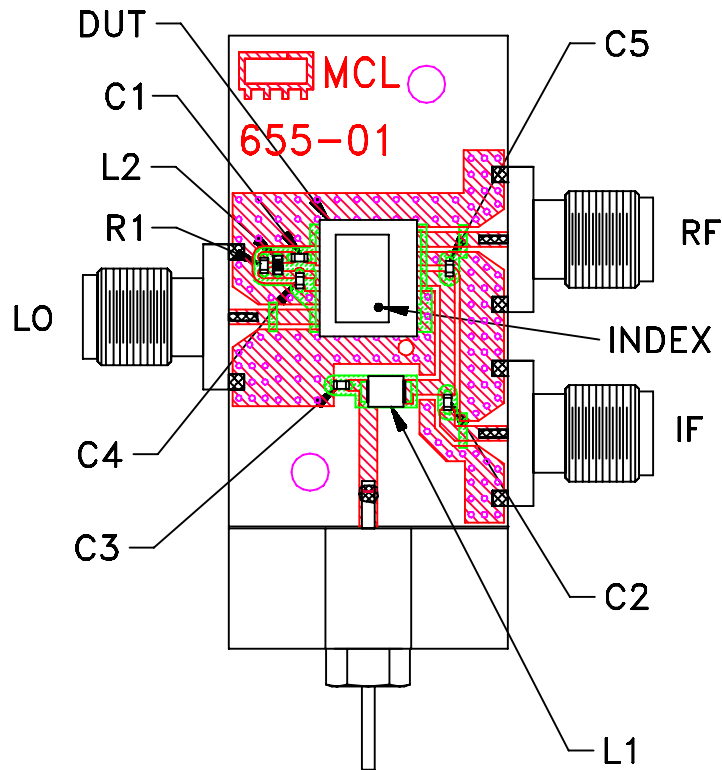

TB-660-42MH+

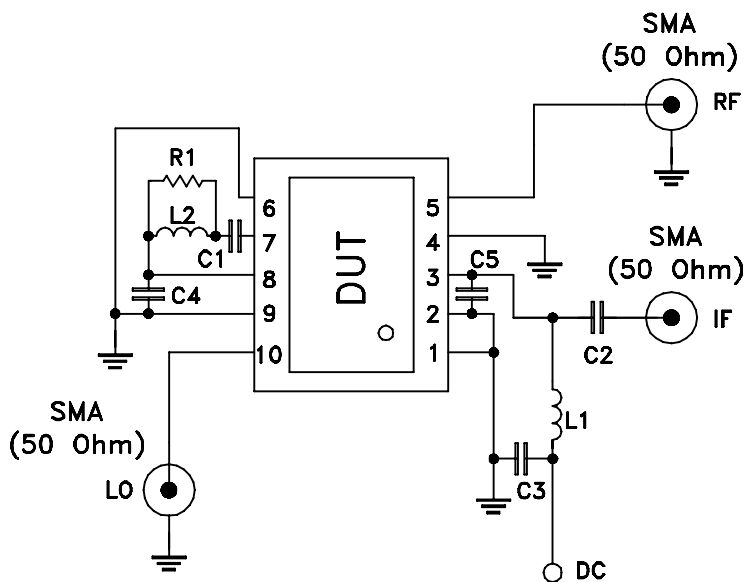

COMPONENT	VALUE
DUT	MRA-42MH+
C1,C2	0.001 μ F
C3	0.1 μ F
C4	2.0 pF
C5	1.0 pF
L1	1.5 μ H
L2	6.8 nH
R1	150 Ohm

Schematic Diagram

Notes:

1. 50 Ohm SMA Female connectors.
2. PCB Material: R04350 or equivalent,
Dielectric Constant=3.5, Thickness=.020 inch.

 **Mini-Circuits®**