

Evaluation Board and Circuit

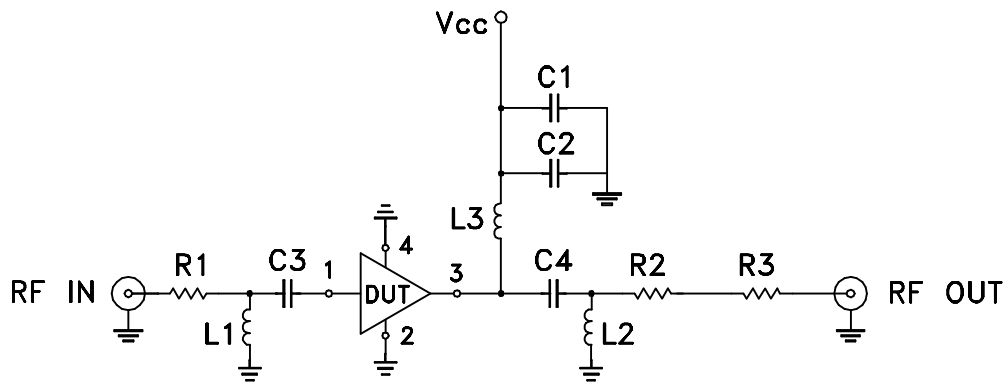
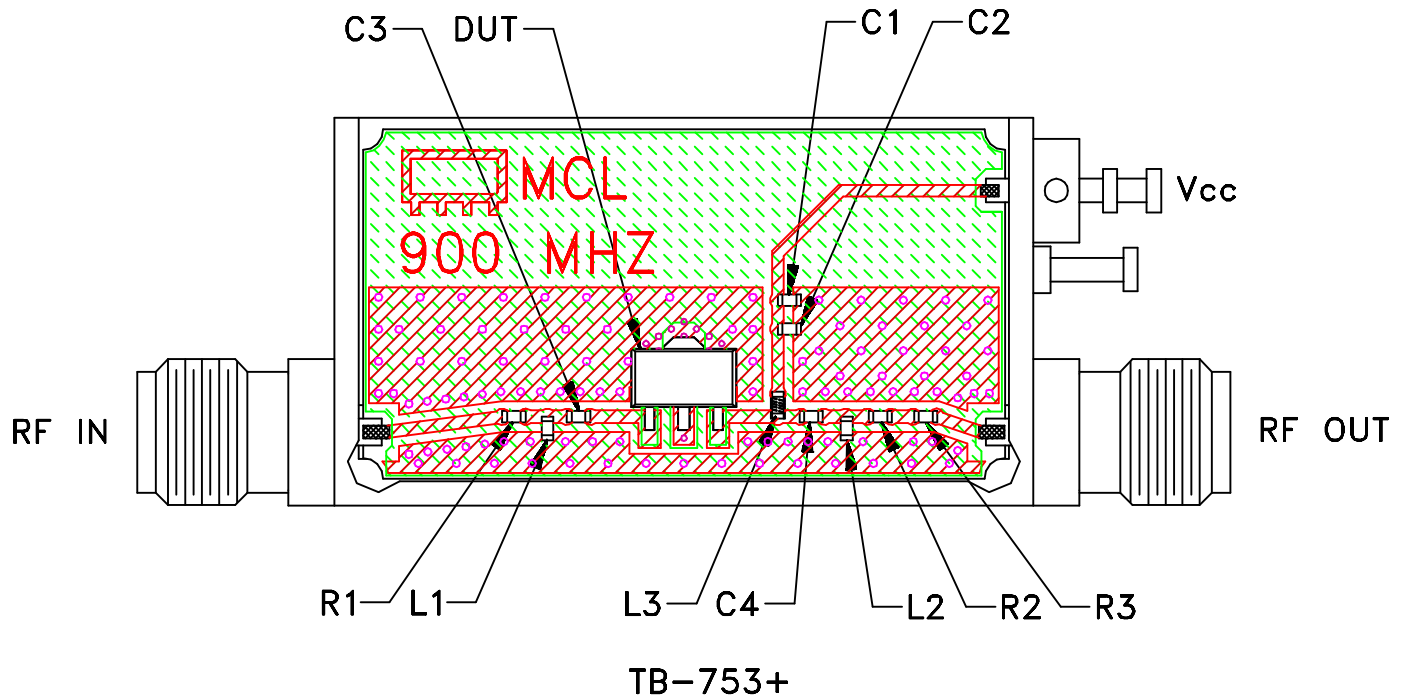

COMPONENT	VALUE	SIZE
DUT	GVA-91+	0402
C1	1.0 μ F	
C2	100 pF	
C3	8.2 pF	
C4	6.2 pF	
R1,R2,R3	0 Ohm	
L1	2.7 nH	
L2	5.6 nH	
L3	33 nH	

Schematic Diagram

Notes:

1. 50 Ohm SMA Female connectors.
2. PCB Material: R04350 or equivalent,
Dielectric Constant=3.5, Thickness=.010 inch.

Mini-Circuits®