

# Evaluation Board and Circuit

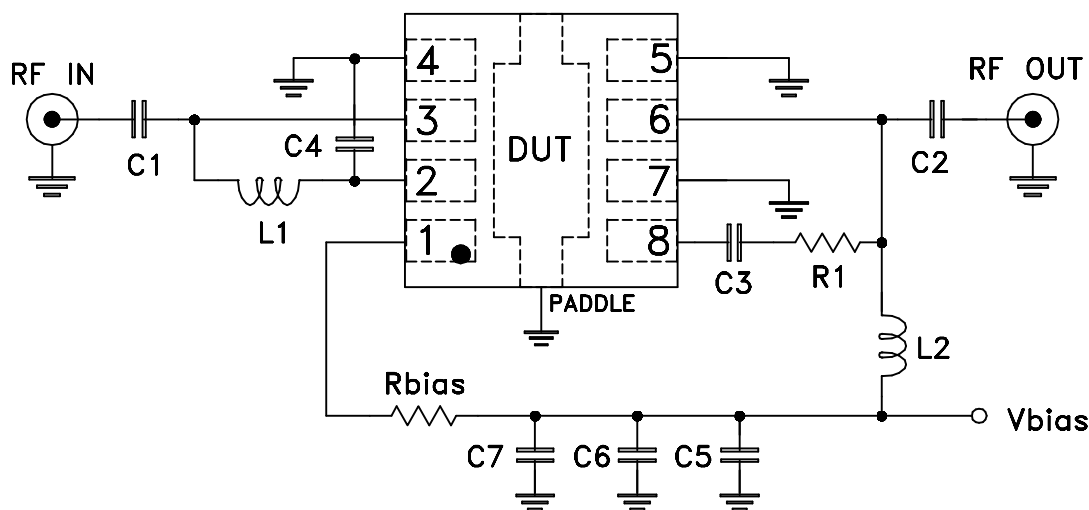
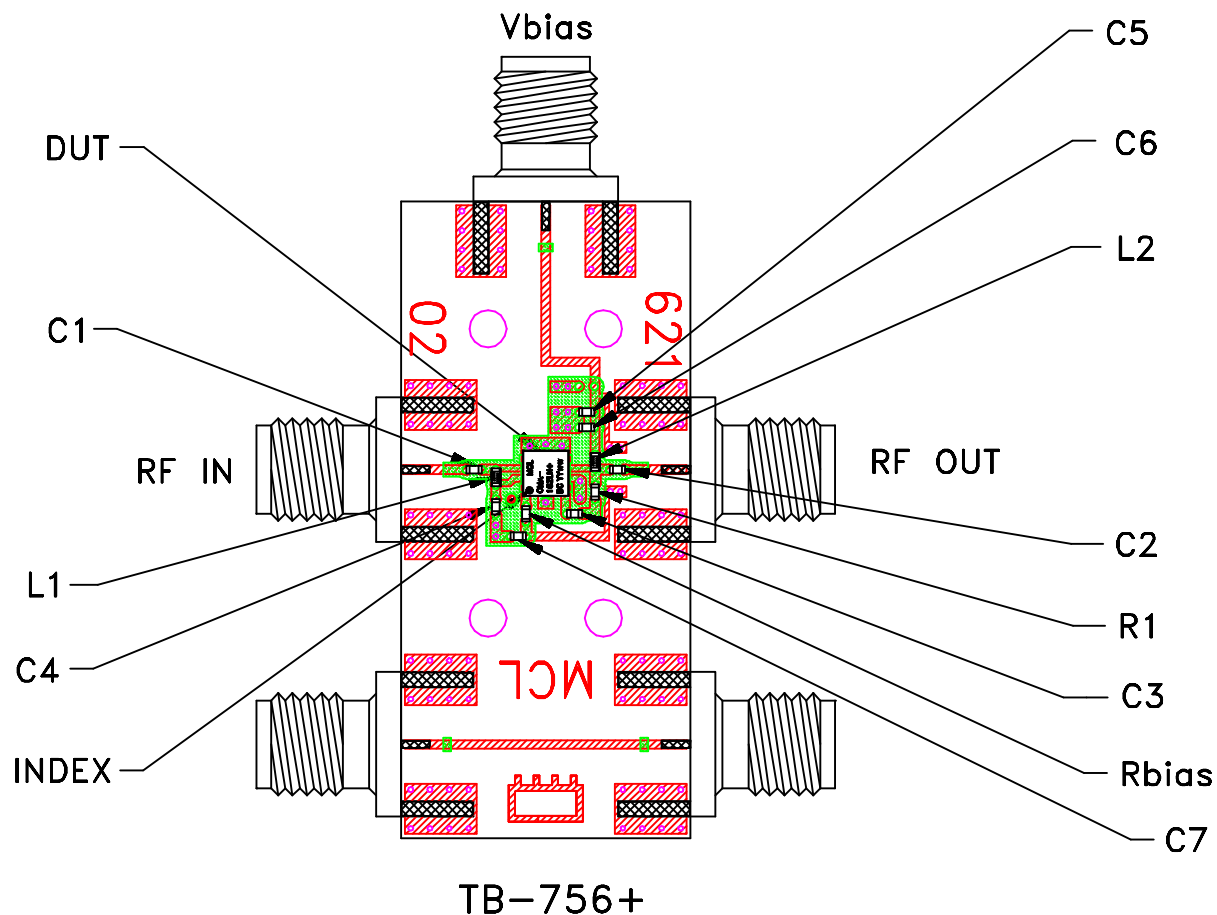

Schematic Diagram

ITEM	DESCRIPTION
C1, C6	CAP, 9.1pF
C2, C4	CAP, 100pF
C3	CAP, 5.6pF
C5, C7	CAP, 0.1uF
R1	RES, 267 Ohm
Rbias	RES, 750 Ohm
L1	IND, 6.8nH
L2	IND, 15nH
DUT	CMA-162LN+

## NOTES:

1. SMA Female connectors.
2. PCB material: Rogers R04350 or equivalent, dielectric constant=3.5, dielectric thickness=.010 inch.

 Mini-Circuits®