

Evaluation Board and Circuit

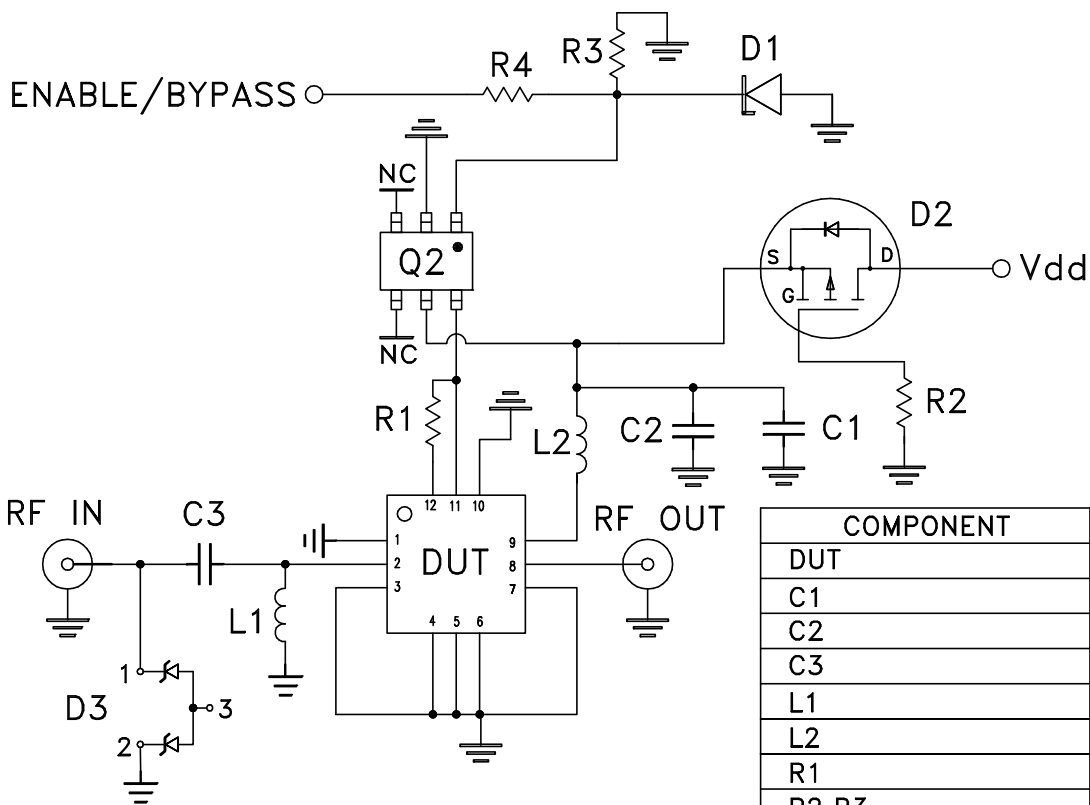
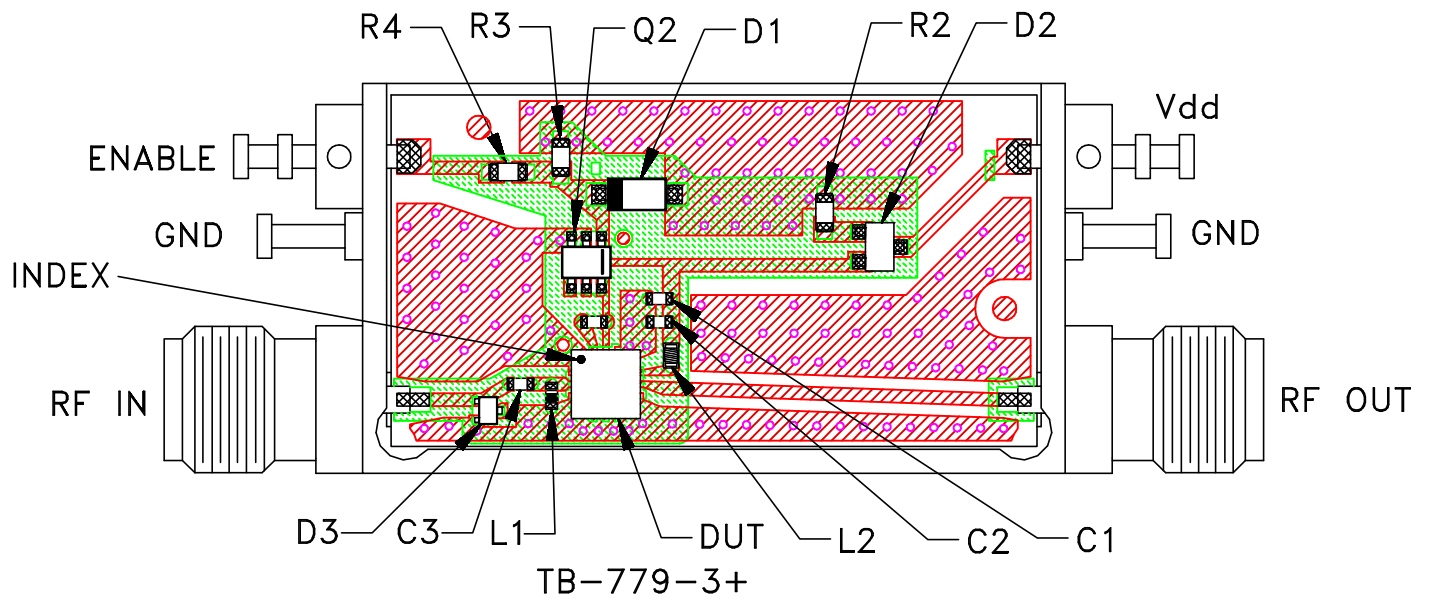

Schematic Diagram

COMPONENT		VALUE	SIZE
DUT		TSS-53LNB+	
C1		.1 uF	SIZE
C2		10 pF	
C3		.001 uF	
L1		47 nH	0402
L2		56 nH	
R1		3.92 kOhm	0603
R2,R3		10 kOhm	
R4		1 kOhm	
D1	MCL	B40-28-5230B+	0603
	ON SEMI	MMSZ5230BT1G	
D2	MCL	B43-4101PT1+	
	ON SEMI	NTS4101PT1G	
D3	MCL	B40-ESD7L5+	
	ON SEMI	ESD7L5.0DT5G	
Q2	MCL	B49-SN74-17+	
	TEXAS INSTRUMENT	SN74LVC2G17DCKR	

Notes:

- 50 Ohm SMA Female connectors.
- PCB Material: R04350 or equivalent, Dielectric Constant=3.5, Thickness=.010 inch.

