

Evaluation Board and Circuit

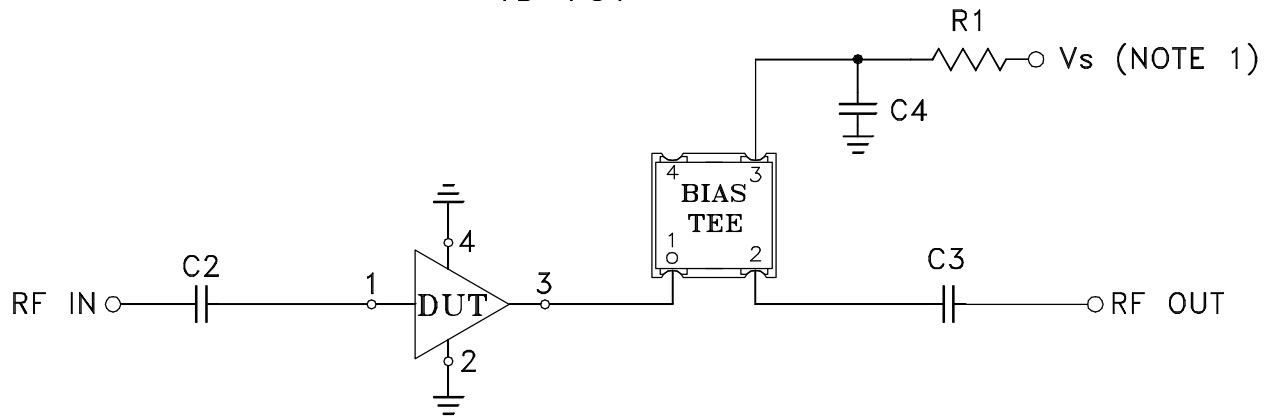
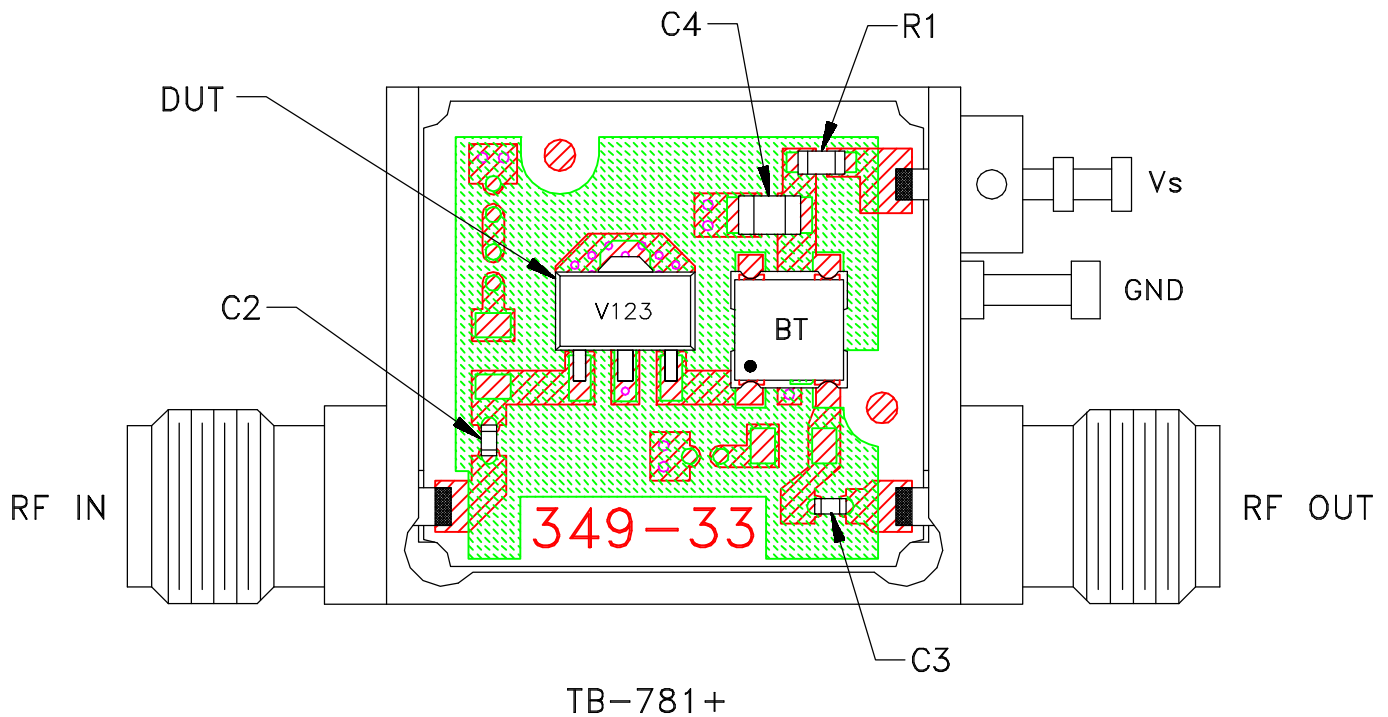

COMPONENT	VALUE	SIZE
DUT	GVA-123+	SOT-89
C1	NOT USED	
C2,C3	0.001 uF	0402
C4	0.1 uF	0805
R1	16.5 Ohm	0603
BIAS TEE	Mini-Circuits TCBT-14+	

NOTES:

1. Vs voltage: $+5 \pm 0.2V$.
2. SMA Female connectors.
3. PCB material: Rogers R04350 or equivalent, dielectric constant=3.5, dielectric thickness=.020 inch.

Schematic Diagram

Mini-Circuits®