

Evaluation Board and Circuit

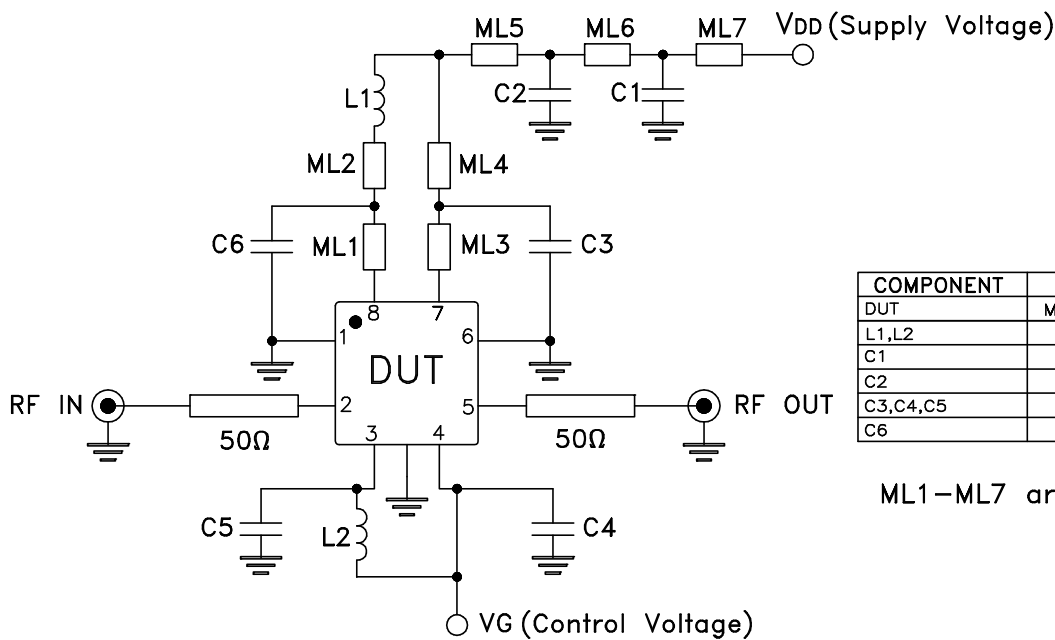
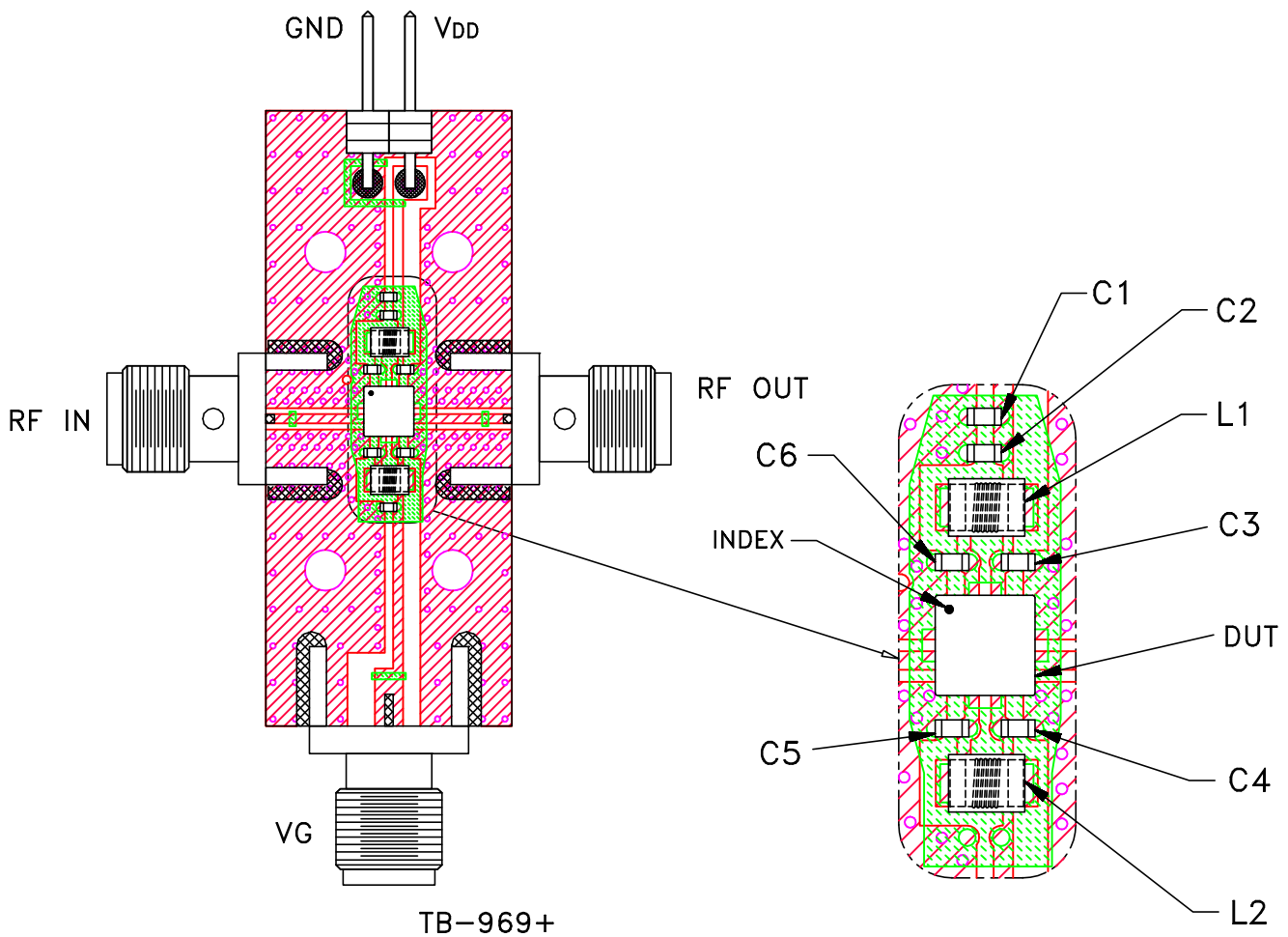

COMPONENT	TYPE AND VALUE	SIZE
DUT	Mini-Circuits TSS-183A+	3X3 mm
L1,L2	Inductor 3.3 nH	0805
C1	Capacitor 5.6 pF	0402
C2	Capacitor 18 pF	
C3,C4,C5	Capacitor .001 uF	
C6	Capacitor .1 uF	

ML1-ML7 are short microstrip lines

Schematic Diagram

Notes:

1. 50 Ohm SMA Female connectors.
2. PCB Material: R04350 or equivalent,
Dielectric Constant=3.5, Thickness=.010 inch.

 **Mini-Circuits®**