

Evaluation Board and Circuit

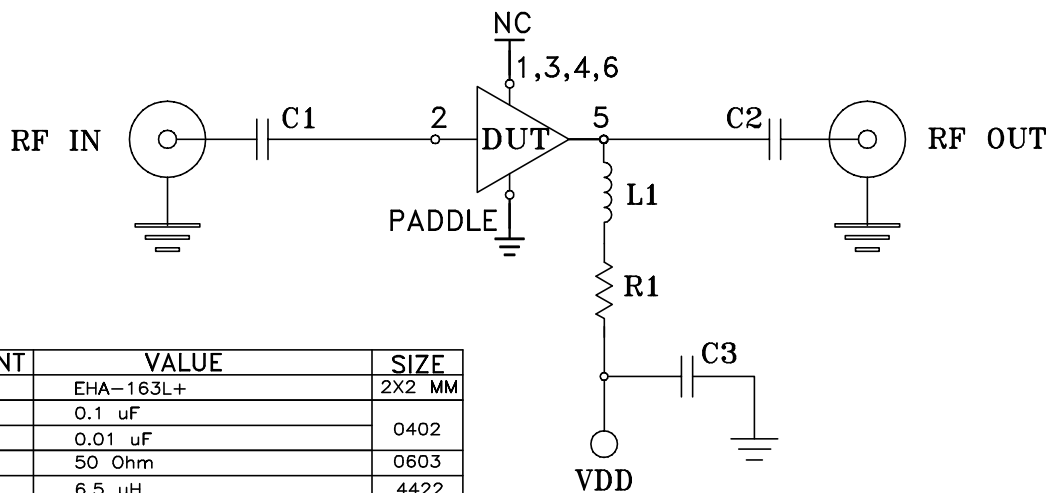
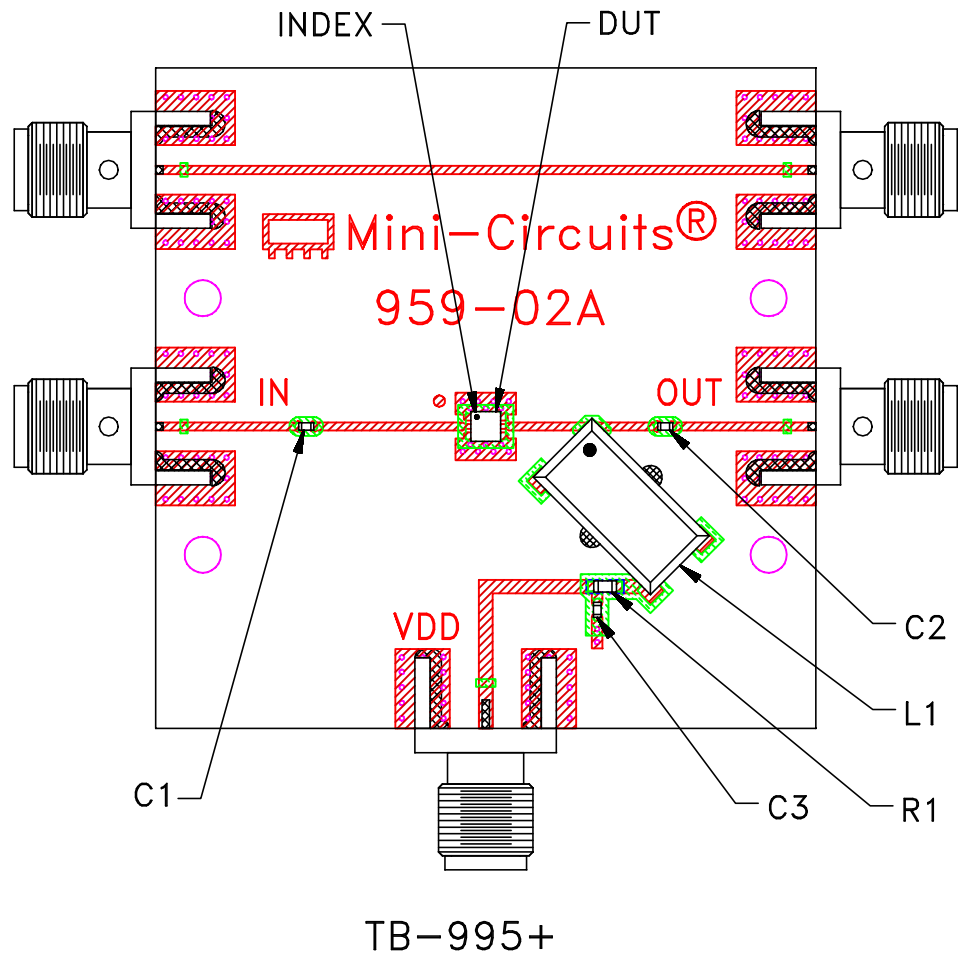

COMPONENT	VALUE	SIZE
DUT	EHA-163L+	2X2 MM
C1,C2	0.1 μ F	0402
C3	0.01 μ F	
R1	50 Ohm	0603
L1	6.5 μ H	4422

Schematic Diagram

Notes:

1. 50 Ohm SMA Female connectors.
2. PCB Material: R04350 or equivalent,
Dielectric Constant=3.5, Thickness=.010 inch.

