

# Evaluation Board and Circuit

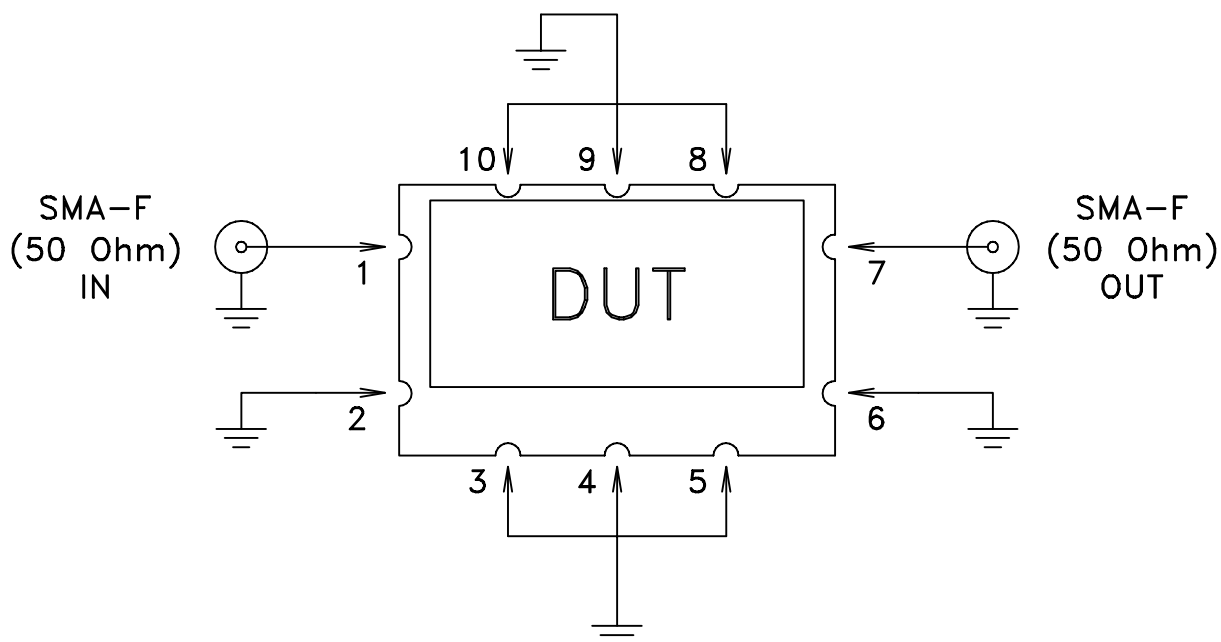
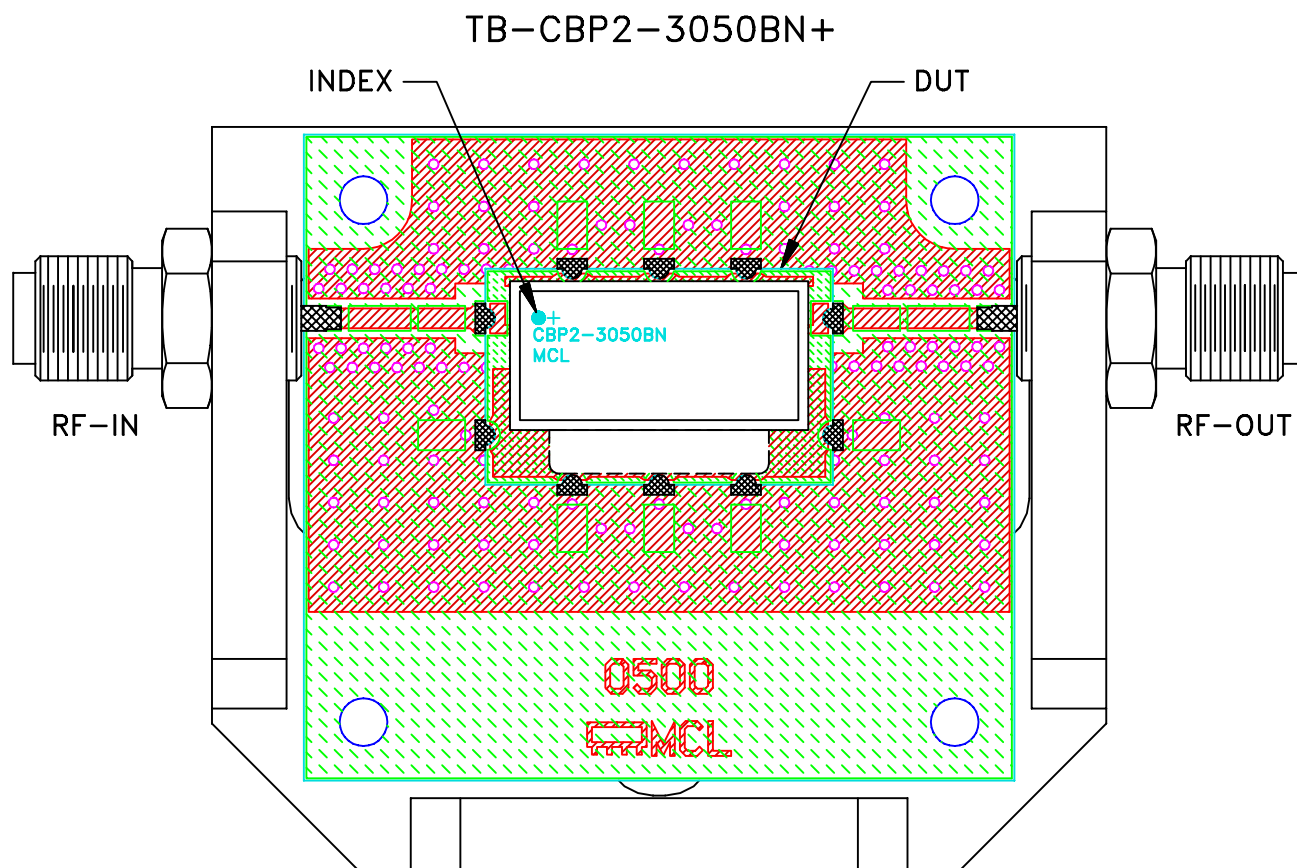

Schematic diagram

**Notes:**

1. 50 Ohm SMA female connectors.
2. PCB Material: R04350B OR Equivalent  
Dielectric Constant=3.48±.05, Thickness=.020 inch.

 **Mini-Circuits®**