

Evaluation Board and Circuit

SEE DETAIL "A"

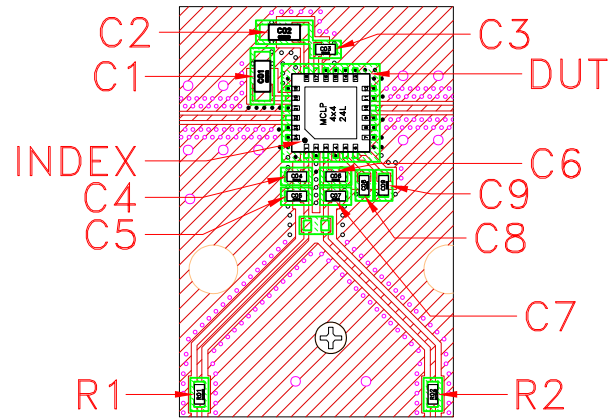

DETAIL "A"
LOCATION OF UNITS COMPONENTS
(SCALE 2:1)

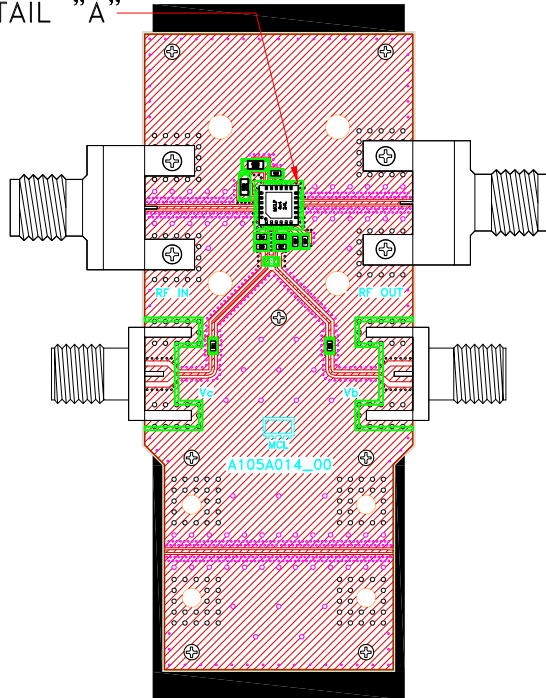
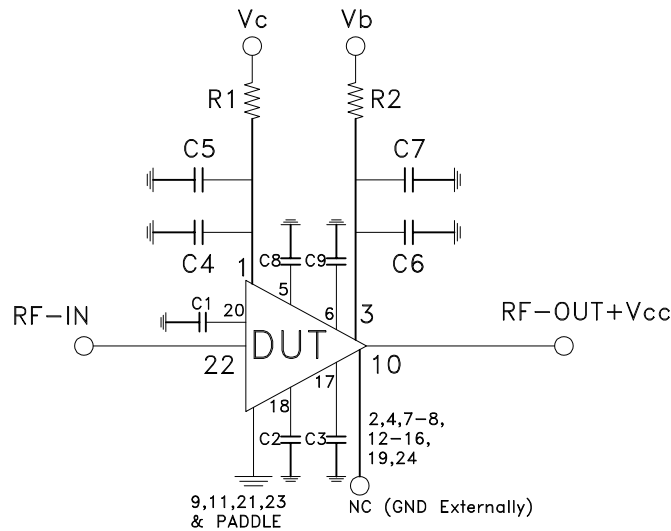

SCHEMATIC DIAGRAM

Component	Size	Value	Part Number	Manufacturer
C1	0603	5100pF	GCM1885C1H512JA16D	Murata
C2	0603	1uF	GCM188R71E105KA64J	Murata
C3,C9	0402	1000pF	GRM1555C1H102JA01D	Murata
C4,C6	0402	100pF	GRM1555C1H101JA01D	Murata
C5,C7,C8	0402	0.1uF	GRM155R71H104KE14J	Murata
R1,R2	0402	00hm	RK73Z1ETTP	KOA Speer

Notes:

- 2.92mm Female Connectors.
- PCB Material: Roger R04350B or equivalent,
Dielectric constant=3.5, Thickness=0.0066 inch

 Mini-Circuits®