

Evaluation Board and Circuit

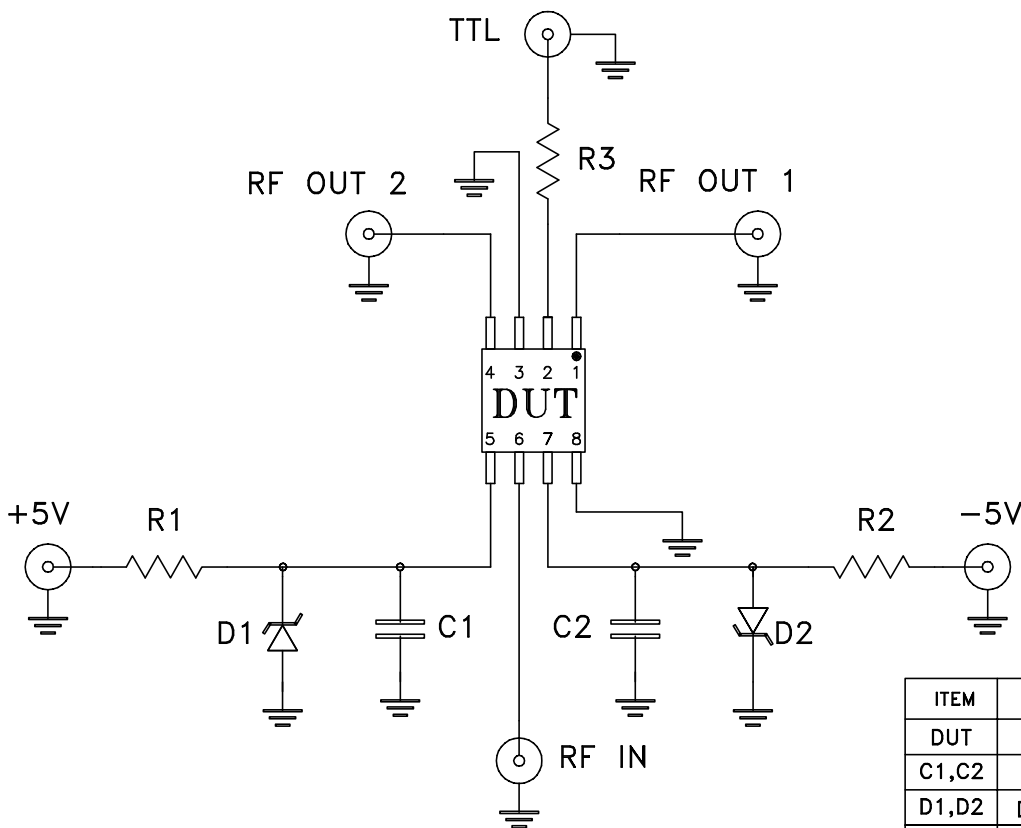
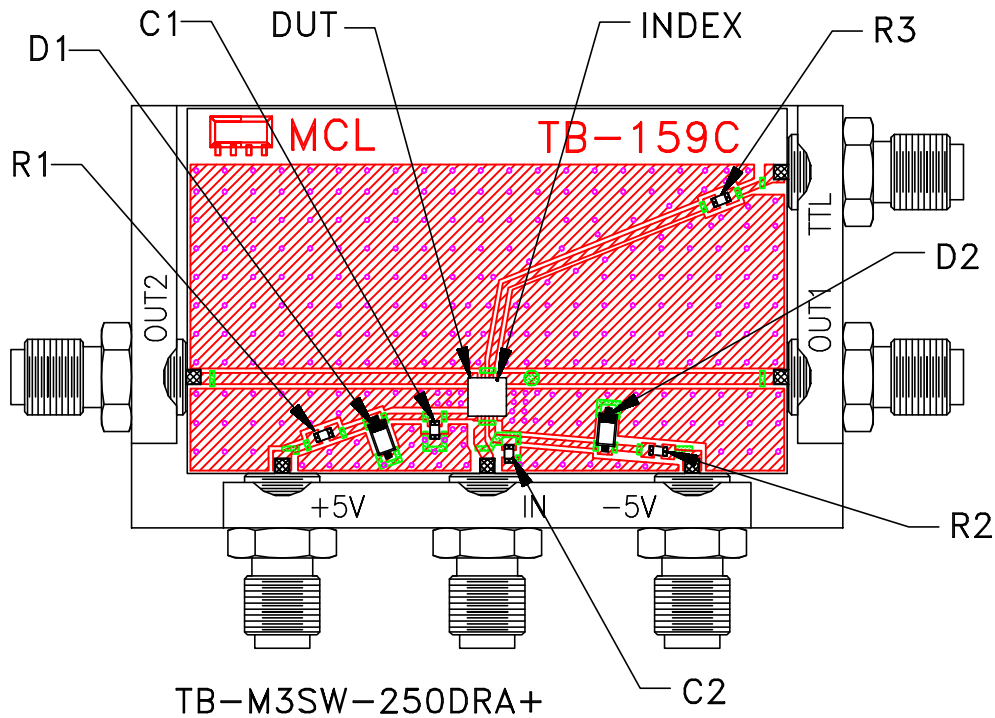

Schematic Diagram

ITEM	DESCRIPTION	SIZE
DUT	MCL SWITCH	3.25X3.25 MM
C1,C2	Capacitor 10 pF	0603
D1,D2	Diod Zener 5.6V	SOT-123
R1,R2	Resistor 11.5 Ohm	0603
R3	Resistor 100 Ohm	

Notes:

1. SMA Female connectors.
2. PCB Material: Rogers R04350 or equivalent, Dielectric Constant=3.5, Thickness=.020 inch.
3. TB name "TB-159C" marked on PCB may be ignored. The correct TB name is TB-M3SW-250DRA+.

 **Mini-Circuits®**