

Evaluation Board and Circuit

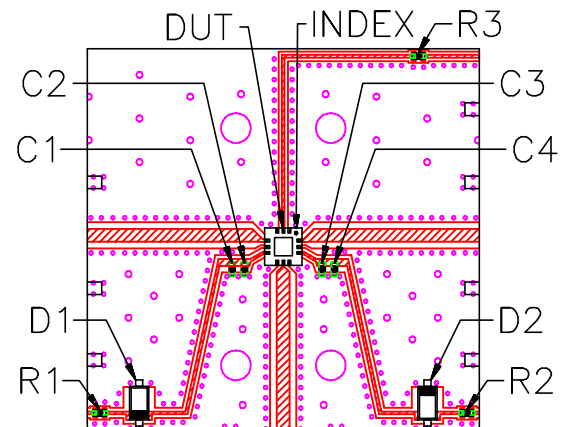

DETAIL "A"
LOCATION OF COMPONENTS
ON THE PCB
(SCALE 1.5:1)

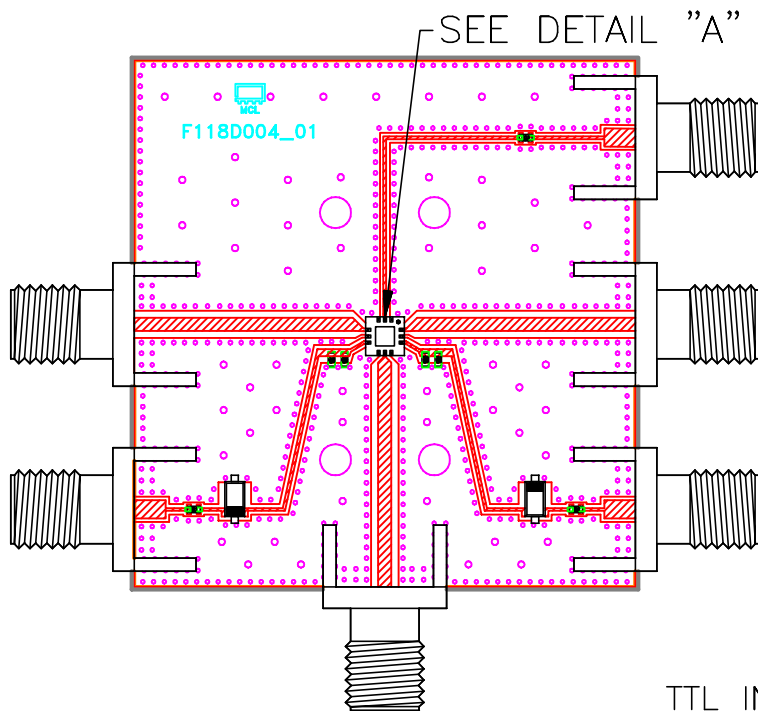
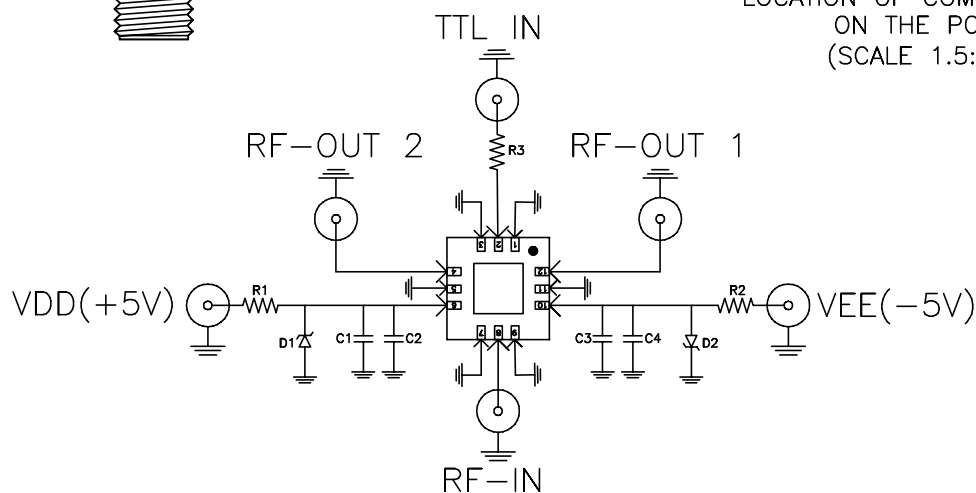

SCHEMATIC DIAGRAM
(SCALE 3:1)

Component	Size	Value	Part Number	Manufacturer
C2,C3	0402	0.5pF	GRM1555C1HR50BA01D	Murata
C1,C4	0402	1pF	GJM1555C1H1R0CB01D	Murata
R1,R2	0402	11.50hm	RP73PF1E11R5BTDF	TE Connectivity
R3	0402	1000hm	RK73H1ETTP1000F	Koa
D1,D2	SOD-123	Vz=5.6V	SZMMSZ5232BT1G	ON Semiconductor

Notes:

- 50 Ohm SMA Female Connectors.
- PCB Material: Roger R04350B or equivalent,
Dielectric constant=3.5, Thickness=0.020 inch

 **Mini-Circuits®**