

Evaluation Board and Circuit

SEE DETAIL "A"

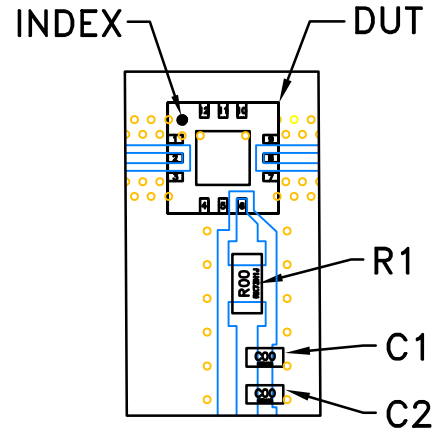

DETAIL "A"
(SCALE 3:1)

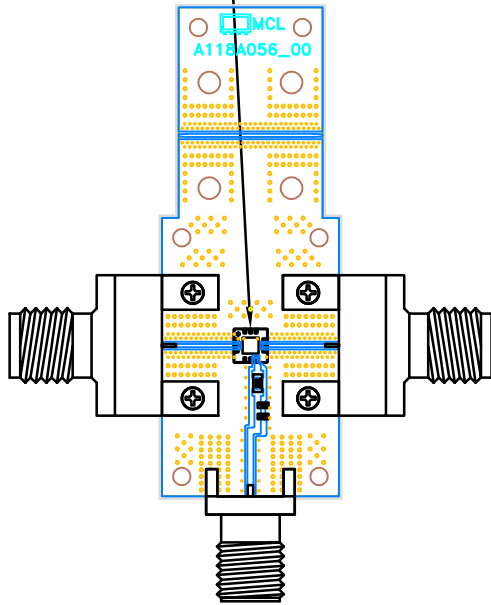
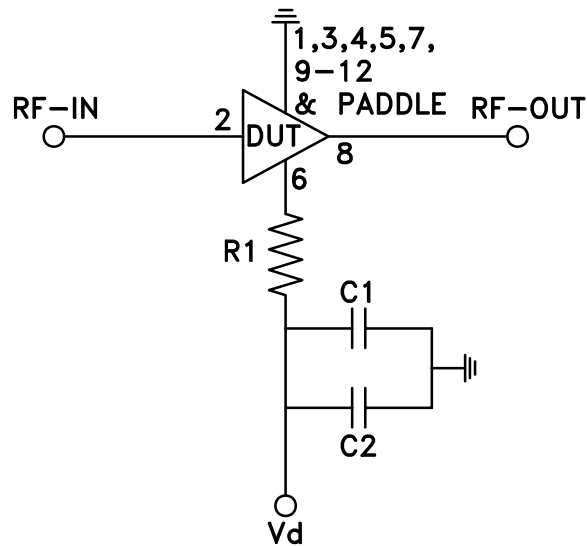

SCHEMATIC DIAGRAM

Component	Size	Value	Part Number	Manufacturer
R1	0603	180hm	SG73G1JTTD18R0C	Koa Speer
C1	0402	5pF	GJM1555C1H5R0CB01D	Murata
C2	0402	0.1uF	GRM155R71C104KA88D	Murata

Notes:

- 2.4mm Female Connectors,
- PCB Material: Roger RO4350B or equivalent,
Dielectric constant=3.5, Thickness=0.0066 inch.

 Mini-Circuits®