

# Ultra Linear Low Noise, Ceramic Monolithic Amplifier

CMA-103+

50Ω □ 0.05 to 4 GHz

## The Big Deal

- Ceramic, hermetically sealed, nitrogen filled
- Low profile case, 0.045”
- Ultra High IP3
- Broadband High Dynamic Range



CASE STYLE: DL1721

MIL Screening Available  
Please consult Applications Dept.

## Product Overview

Mini-Circuits' CMA-103+ is an advanced wideband amplifier fabricated using E-PHEMT technology and offers extremely high dynamic range over a broad frequency range and with low noise figure. In addition, the CMA-103+ has good input and output return loss over a broad frequency range without the need for external matching components and has demonstrated excellent reliability. The amplifier is bonded to a multilayer integrated LTCC substrate, then hermetically sealed under a controlled Nitrogen atmosphere with gold-plated cover, eutectic Au-Sn solder, and Ni-Pd-Au termination finish. CMA-series amplifiers are capable of meeting MIL requirements for gross leak, fine leak, thermal shock, vibration, acceleration, mechanical shock, and HTOL. The testing can be done if requested.

## Key Features

Feature	Advantages
Hermetically Sealed	Ideal for use anywhere long-term reliability adds bottom-line value: high moisture areas, busy production lines, high-speed distribution centers, heavy industry, outdoor settings, and unmanned facilities, as well as military applications.
Broad Band: 0.05 to 4.0 GHz	Broadband covering primary wireless communications bands: Cellular, PCS, LTE, WiMAX
Ultra High IP3 Versus DC power Consumption: 45 dBm typical at 2 GHz at +5.0V Supply Voltage and only 97mA	The CMA-103+ provides excellent IP3 performance relative to device size and power consumption. The combination of the design and E-PHEMT Structure provides enhanced linearity over a broad frequency range as evidence in the IP3 being typically 20 dB above the P 1dB point. This feature makes this amplifier ideal for use in: <ul style="list-style-type: none"> <li>• Driver amplifiers for complex waveform up converter paths</li> <li>• Drivers in linearized transmit systems</li> <li>• Secondary amplifiers in ultra High Dynamic range receivers</li> </ul>
Low Noise Figure: 0.5 dB up to 1.0 GHz	A unique feature of the CMA-103+ which separates this design from all competitors is the low noise figure performance in combination with the high dynamic range.
Ceramic, hermetic package	Low inductance, repeatable performance, outstanding reliability in tough operating conditions, and small size (0.12 x 0.12 x 0.045”)



# Ultra Linear Low Noise, Ceramic Monolithic Amplifier

0.05-4.0 GHz

## Product Features

- Ceramic, hermetically sealed, high reliability
- Low profile case, .045" high
- 5V/3V operation
- High IP3, 45 dBm typ. at 2 GHz, Vd=5V
- Low Noise Figure, 0.5 at 1 GHz; 0.8 dB at 2 GHz
- Gain, 10.9 dB typ. at 2 GHz
- P1dB 23.1 dBm typ. at 2 GHz at Vd=5V



Generic photo used for illustration purposes only

CASE STYLE: DL1721

## CMA-103+

**+RoHS Compliant**

The +Suffix identifies RoHS Compliance. See our web site for RoHS Compliance methodologies and qualifications

## Typical Applications

- High Rel Systems
- Defense and Aerospace
- Base station infrastructure
- Portable Wireless
- CATV & DBS
- MMDS & Wireless LAN
- LTE

## General Description

Mini-Circuits' CMA-103+ is an advanced wideband amplifier fabricated using E-PHEMT technology and offers extremely high dynamic range over a broad frequency range and with low noise figure. In addition, the CMA-103+ has good input and output return loss over a broad frequency range without the need for external matching components and has demonstrated excellent reliability. The amplifier is bonded to a multilayer integrated LTCC substrate, then hermetically sealed under a controlled Nitrogen atmosphere with gold-plated cover, eutectic Au-Sn solder, and Ni-Pd-Au termination finish. CMA-series amplifiers are capable of meeting MIL requirements for gross leak, fine leak, thermal shock, vibration, acceleration, mechanical shock, and HTOL. The testing can be done if requested.

## simplified schematic and pad description

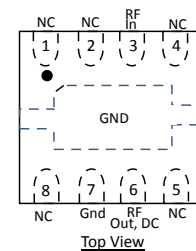
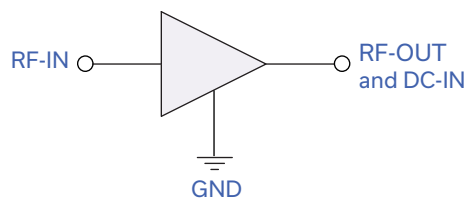

Function	Pad Number	Description
RF IN	3	RF input pin. This pin requires the use of an external DC blocking capacitor chosen for the frequency of operation.
RF-OUT and DC-IN	6	RF output and bias pin. DC voltage is present on this pin; therefore a DC blocking capacitor is necessary for proper operation. An RF choke is needed to feed DC bias without loss of RF signal due to the bias connection, as shown in "Recommended Application Circuit", Fig. 2
GND	7, Paddle	Connections to ground. Use via holes as shown in "Suggested Layout for PCB Design" to reduce ground path inductance for best performance.
NC	1,2,4,5,8	Not used internally. Connected to ground on test board



Electrical Specifications<sup>(1)</sup> at 25°C, 50Ω, unless noted

Parameter	Condition (GHz)	Vd=5V			Vd=3V	Units
		Min.	Typ.	Max.	Typ.	
Frequency Range		0.05				GHz
Gain	0.05	—	26.3	—	25.7	dB
	0.4	—	22.1	—	21.7	
	1.0	14.7	16.3	18.0	16.0	
	2.0	—	11.0	—	10.7	
	3.0	—	7.9	—	7.7	
Noise Figure	4.0	—	5.8	—	5.7	dB
	0.05		0.4		0.3	
	0.4		0.4		0.4	
	1.0		0.5		0.4	
	2.0		0.8		0.9	
Input Return Loss	3.0		1.1		0.8	dB
	4.0		1.3		1.3	
	0.05	—	6.2	—	5.8	
	0.4	—	10.9	—	10.2	
	1.0	10.0	14.0	—	13.0	
Output Return Loss	2.0	—	16.0	—	15.0	dB
	3.0	—	17.3	—	16.4	
	4.0	—	18.6	—	17.3	
	0.05	—	12.9	—	13.0	
	0.4	—	19.9	—	21.8	
Reverse Isolation	1.0	14.0	18.2	—	22.1	dB
	2.0	—	16.4	—	19.9	
	3.0	—	15.2	—	18.2	
	4.0	—	14.5	—	17.1	
	0.05	—	20.0	—	15.6	
Output Power @ 1dB compression <sup>(2)</sup>	0.4		22.1		18.6	dBm
	1.0		22.2		18.9	
	2.0		23.1		19.7	
	3.0		23.5		20.3	
	4.0		24.2		20.9	
Output IP3	0.05	—	37.4	—	34.9	dBm
	0.4	—	39.4	—	32.8	
	1.0	—	42.6	—	33.2	
	2.0	40.0	44.8	—	33.9	
	3.0	—	47.1	—	34.3	
4.0	—	47.9	—	35.0		
Device Operating Voltage		4.8	5.0	5.2	3.0	V
Device Operating Current			97	120	60	mA
DC Current Variation Vs. Temp.			-178		-54	μA/°C
DC Current Variation Vs. Voltage			0.014		0.018	mA/mV
Thermal Resistance, junction-to-ground lead			61		61	°C/W

<sup>(1)</sup> Measured on Mini-Circuits Characterization test board TB-829-103+. See Characterization Test Circuit (Fig. 1)

<sup>(2)</sup> Current increases at P1dB

## Absolute Maximum Ratings

Parameter	Ratings
Operating Temperature (ground lead)	-40°C to 125°C
Storage Temperature	-65°C to 150°C
Operating Current at 5.0V	200 mA
Power Dissipation at 5.0V	1W
Input Power (CW)	+21 dBm (50 to 2000 MHz) +26 dBm (2000 to 4000 MHz)
DC Voltage on Pin 6	6V

Note:

Permanent damage may occur if any of these limits are exceeded.

Electrical maximum ratings are not intended for continuous normal operation.



Characterization Test Circuit

Suggested PCB Layout (PL-602)

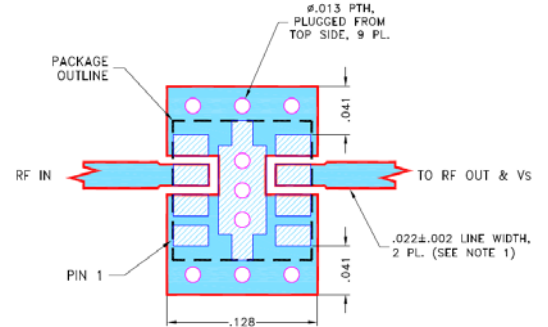
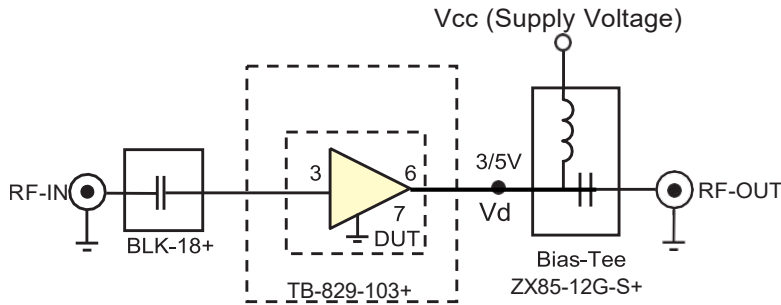

**Fig 1.** Block Diagram of Test Circuit used for characterization. (DUT tested on Mini-Circuits Characterization test board TB-829-103+) Gain, Return loss, Output power at 1dB compression (P1 dB) , output IP3 (OIP3) and noise figure measured using Agilent's N5242A PNA-X microwave network analyzer.

**NOTES:**

1. TRACE WIDTH IS SHOWN FOR ROGERS R04350B WITH DIELECTRIC THICKNESS .020" ± .0015"; COPPER: 1/2 OZ. EACH SIDE. FOR OTHER MATERIALS TRACE WIDTH AND GAP MAY NEED TO BE MODIFIED.
  2. BOTTOM SIDE OF THE PCB IS CONTINUOUS GROUND PLANE.
- DENOTES PCB COPPER LAYOUT WITH SMOBC (SOLDER MASK OVER BARE COPPER)  
 DENOTES COPPER LAND PATTERN FREE OF SOLDER MASK

**Conditions:**

1. Gain and Return loss: Pin= -25dBm
2. Output IP3 (OIP3): Two tones, spaced 1 MHz apart, 5 dBm/tone at output.

Recommended Application Circuit

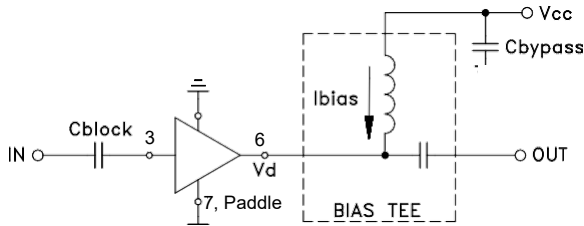

Cblock=0.001µF, Bias-Tee=TCBT-14+, Cbypass=0.1µF

**Fig 2a.** Evaluation board TB-988-103+ includes case, connectors and components soldered to PCB

Product Marking

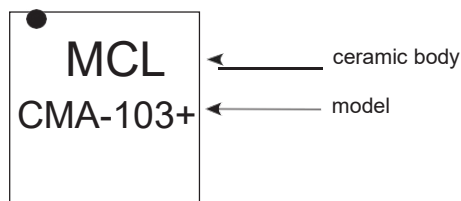

Additional Detailed Technical Information	
additional information is available on our dash board. To access this information <a href="#">click here</a>	
Performance Data	Data Table
	Swept Graphs
	S-Parameter (S2P Files) Data Set (.zip file)
Case Style	DL1721 Ceramic package, exposed paddle, Terminla finish: NiPdAu
Tape & Reel Standard quantities available on reel	F66-1 <i>7" reels with 20, 50, 100, 200, 500 or 1K, 2K devices.</i>
Suggested Layout for PCB Design	PL-602
Evaluation Board	TB-988-103+
Environmental Ratings	ENV-68

**ESD Rating**

Human Body Model (HBM): Class 1A (250 to <500V) in accordance with ANSI/ESD STM 5.1 - 2001

Machine Model (MM): Class M1 (25V) in accordance with ANSI/ESD STM5.2-1999

**MSL Rating**

Moisture Sensitivity: MSL1 (these parts are hermetic, air cavity and therefore, MSL ratings do not strictly apply. For handling purpose, use MSL1)

**Qualification Testing**

The table below shows the initial qualification testing performed. If required, parts can be subjected to 100% screening and qualifications testing per MIL standard requirement.

Test Description		Test Method/Process	Results
1	Hermeticity (fine and gross leak)	MIL-STD-202 Method 112, Cond. C & D	Pass
2	Acceleration, 30Kg, Y1 Direction	MIL-STD-883 Method 2001 Cond. E	Pass
3	Vibration , 10-2000Hz sine, 20g, 3 axis	MIL-STD-202 Method 204, Cond. D	Pass
4	Mechanical shock	MIL-STD-202 Method 213, Cond . A	Pass
5	PIND 20G's @130 Hz	MIL-STD-750 Method 2052.2	Pass
6	Temp Cycle -55C/+125C, 1000 Cycles	MIL-STD-202 Method 107	Pass
7	Autoclave, 121C, RH 100%, 15 Psig, 96 hrs	JESD22-A102C	Pass
8	HTOL, 1000hrs, 105C at rated Voltage condition	MIL-STD-202 Method 108, Cond . D	Pass
9	Bend Test	JESD22-B113	Pass
10	Resistance to soldering heat, 3x reflow, 260C peak	JESD22-B102	Pass
11	Drop Test	JESD22-B111	Pass
12	Adhesion Strength	Push Test>10 lb	Pass

**Additional Notes**

- A. Performance and quality attributes and conditions not expressly stated in this specification document are intended to be excluded and do not form a part of this specification document.
- B. Electrical specifications and performance data contained in this specification document are based on Mini-Circuit's applicable established test performance criteria and measurement instructions.
- C. The parts covered by this specification document are subject to Mini-Circuits standard limited warranty and terms and conditions (collectively, "Standard Terms"); Purchasers of this part are entitled to the rights and benefits contained therein. For a full statement of the Standard Terms and the exclusive rights and remedies thereunder, please visit Mini-Circuits' website at [www.minicircuits.com/MCLStore/terms.jsp](http://www.minicircuits.com/MCLStore/terms.jsp)

